

Instruction Cross Reference

Bulletin No.	Description
M4351-20	High Frequency Pulse Generator (HFPG)
M4352-20	Impulse Contactor
(S)X-4400	Automatic Temperature Compensator (ATC)
(S) X-4200	4200 Adjustor



CAUTION: It is recommended that this publication be read in its entirety before performing any operation. Failure to understand and follow these instructions could result in serious personal injury and/or damage to the equipment.

Should this equipment require repair or adjustment, contact the nearest Sales Office. It is important that servicing be performed only by trained and qualified service personnel. If this equipment is not properly serviced, serious personal injury and/or damage to the equipment could result.

**Brodie Meter Co., LLC**

P.O. Box 450
19267 Highway North (30461)
Statesboro, GA 30459-0450
Phone: (912) 489-0200
Fax: (912) 489-0295
www.brodiemeter.com

TABLE OF CONTENTS

	Paragraph Number	Page Number
Section 1 INTRODUCTION		
General.....	1-1	3
Description - Measuring Unit	1-2	3
Meter Model Number.....	1-3	3
Specifications	1-4	3
Section 2 INSTALLATION		
General.....	2-1	5
Receipt of Equipment	2-2	5
Return Shipment	2-3	5
Recommended Procedures.....	2-4	5
Section 3 OPERATION		
General.....	3-1	5
Section 4 MAINTENANCE		
General.....	4-1	6
Removal of Measuring Unit	4-2	6
Disassembly of Measuring Unit	4-3	6
Cleaning Measuring Unit	4-4	7
Reassembly - Measuring Unit.....	4-5	8
Timing Gear Adjustment.....	4-6	8
Adjusting End Clearance	4-7	8
Completion of Measuring Unit Reassembly	4-8	8
Section 5 TROUBLESHOOTING		
General	5-1	9
Section 6 PARTS LIST		
General.....	6-1	9

LIST OF FIGURES

	Figure Number	Page Number
Dimensions	1-1	4
Blocking Rotors	4-1	7
Filing Rotors	4-2	7
General Assembly- Model BA-80AL.....	6-1	10
Measuring Unit Assembly	6-2	11
Counter Base Plate Assembly.....	6-3	12

LIST OF TABLES

	Table Number	Page Number
Dimensions.....	1-1	4
Troubleshooting.....	5-1	9
Parts List- General Assembly	6-1	10
Parts List - Measuring Unit Assembly.....	6-2	11
Counter Base Plate Assembly.....	6-3	12

Section 1 INTRODUCTION

1-1 General

The Model BA-80AL All Aluminum-Axial Flow BiRotor meter offers the exclusive BiRotor principle of operation - no sliding, oscillating or reciprocating parts. A rugged but simple design plus two rotors that are statically and dynamically balanced means long life and low maintenance costs. High accuracy is retained over a flow range of 60 to 600 G.P.M.

This BiRotor meter occupies a minimum of space and meets U.S. Military specifications for non-ferrous construction of aircraft refueling equipment. No ferrous or copper bearing materials are in contact with the metered liquid, only aluminum or stainless steel.

1-2 Description - Measuring Unit

The meter generally consists of a measuring unit installed in an outer housing or case, an adjustor for calibrating the meter and the necessary counter equipment for registering the amount of liquid thruput.

The principle of operation of the meter is embodied in the function of the two rotors which are the only moving parts within the measuring unit. They are always dynamically balanced but hydraulically unbalanced. The rotors are not in metal-to-metal contact with one another or with the housing in which they rotate. They are maintained in proper timed relationship with one another by helical gears. They divide the volume being measured into segments, separate each segment from the flowing stream momentarily, then return them to the stream. The segments of flow are counted and the results are transferred to a totalizing register or other flow recording device by means of a gear train.

The BiRotor Meter is unique in that it does not use any sliding vanes or reciprocating parts, nor are there any shock loads on the mechanism during operation resulting from the shifting of off-balance masses.

An accuracy adjustor, located on the output of the counter drive gearing, permits the operator at the time of installation to adjust the output of the measuring unit to read in an exact number of units of volume. Thus, the accuracy adjustor acts as a variable gear changer (similar to the speeding up or slowing down of the timing of a watch) and allows an adjustment of + 3% of meter thruput. The meter may be supplied with any of several accessory items, such as high frequency pulse generator, impulse contactor, automatic temperature compensator (ATC), etc. The units provide various functions for local and/or remote control and local and/or remote readout.

NOTE: Before placing the meter in service, refer to the appropriate instruction manual for these accessory units if the meter is so equipped.

1-3 Meter Model Number

The model number, serial number, flow range, and operating pressure appear on the nameplate attached to the meter body.

1-4 Specifications

The following specifications apply to the meter unless otherwise noted.

CAUTION: Do not use this meter in excess of the below specified values.

Materials of Construction

Housing: Aluminum
Measuring Unit:
Body and End Covers: Aluminum
Rotors: Aluminum
Rotor Shafts: Nitralloy
Rotor Bearings: Stainless Steel
Counter Base Plate:
Body: Aluminum
Counter Drive Shafts: Stainless Steel
Counter Drive Gears: Stainless Steel
O-Rings:
Drive Shaft: Viton Standard
Housing: Buna-N Standard

Connections

4" 1501b. Victaulic or 4" 1501b. ANSI RF Flanges

Ratings

Maximum Safe Working Pressure: 150 PSI (1034 kPa)
Maximum Safe Working Temperature: 150°F (66°C)

Performance

Repeatability: + 0.05%
Linearity: $\pm 0.3\%$

Capacity

Flow Capacity: 60 to 600 U.S.G.P.M.
50 to 500 Imp. G.P.M.
86 to 857 BbIs Per Hour
227 to 2271 Litres Per Minute

Typical Pressure Drop Curve

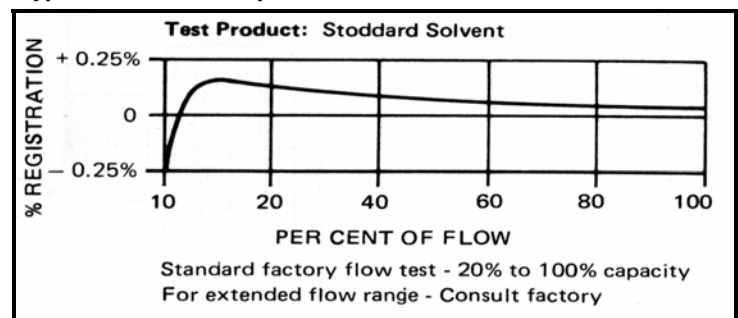

Typical Accuracy Curve

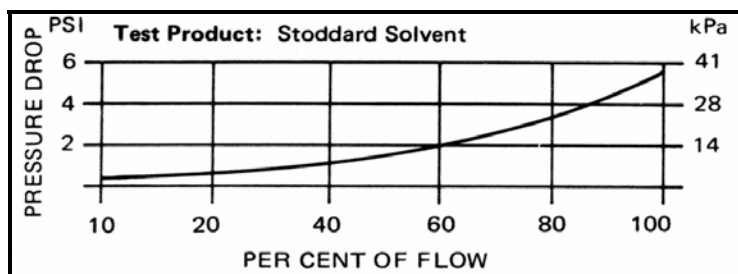
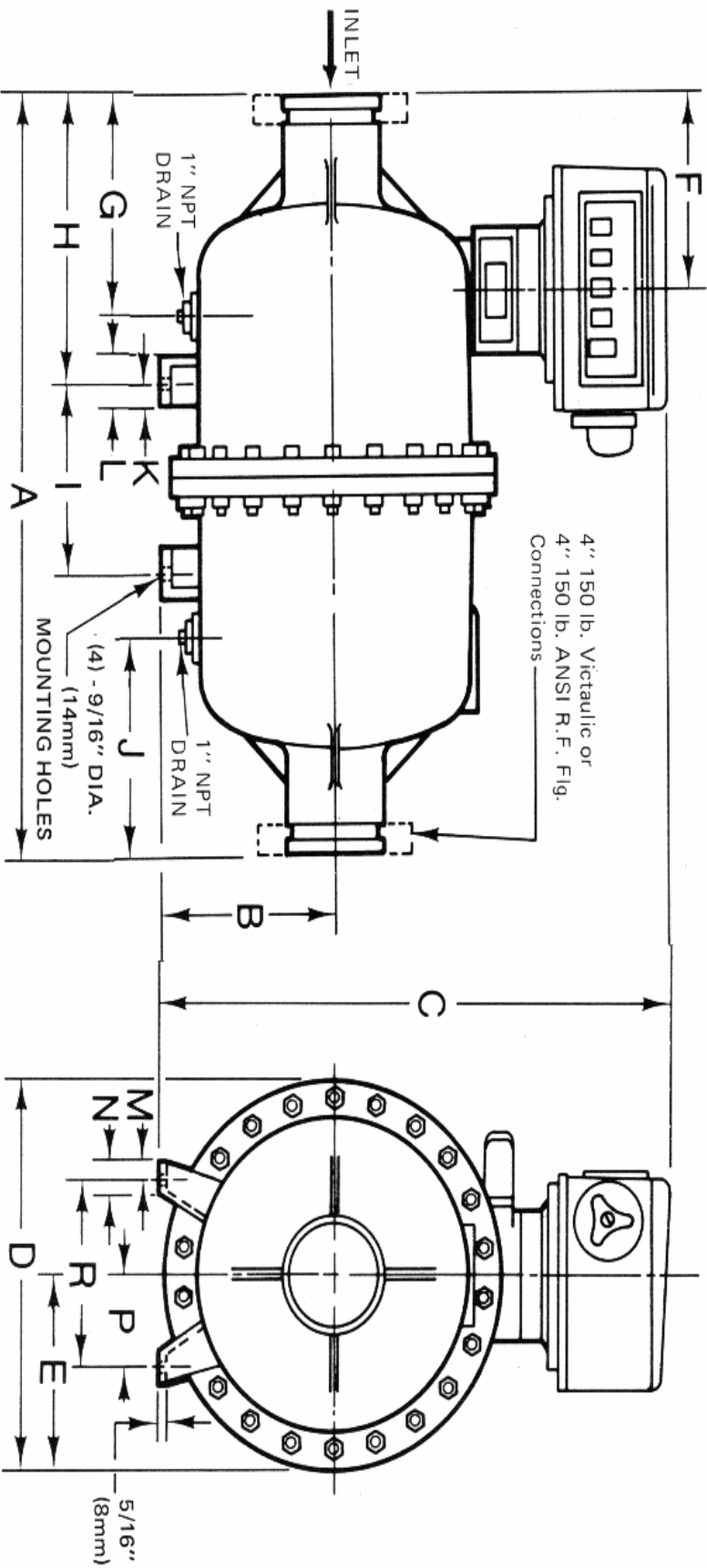

Figure 1-1 DIMENSIONS—Shown with Accuracy Adjustor and Large Dial Register
 (For Certified Dimension Prints—Consult Factory)



Dimensions	A	B	C	D	E	F	G	H	I	J	K	L	M	N	P	R
Inches	29-3/8	8	23-3/8	15-5/8	7-13/16	7-9/16	8-9/16	11-3/16	7	8-9/16	1	2	25/32	1-9/16	3-11/16	7-3/8
Millimeters	746	203	594	397	198	192	217	284	178	217	25	51	25/32	1-9/16	94	187

Section 2 INSTALLATION

2-1 General

This section contains the procedures for receipt and installation of the meter. Specific instructions are provided for accessory equipment.

2-2 Receipt of Equipment

When the equipment is received, the outside of the packing case should be checked for any damage incurred during shipment. If the packing case is damaged, the local carrier should be notified at once regarding his liability.

A report should be submitted to the Product Service Department, Brodie Meter Co., LLC, Statesboro, Georgia 30458.

Remove the envelope containing the packing list. Carefully remove the equipment from the packing case. Make sure spare or replacement parts are not discarded with the packing material. Inspect for damaged or missing parts.

In many cases the accessory items that form the "stack-up" of the meter have not been shipped assembled to the meter. The "stack-up" assembly will be shipped as a complete unit where possible. If not, it will be broken apart into as few assemblies as is practical. Refer to the the Packing List for information as to what is supplied for your particular meter. In the event that any items are missing from your shipment, contact your local representative or sales office. Provide him with the serial number and sales order number.

2-3 Return Shipment

To be able to process returned goods quickly and efficiently, it is IMPORTANT that you provide essential information. Do not return any assembly or part without an "R.M.R." (Returned Material Report) or a letter which describes the problem, corrective action (if any) and the work that is to be performed at the factory. "R.M.R." forms can be obtained from sales offices or the Service Department, Brodie Meter Co., LLC, Highway 301 North, Statesboro, Georgia 30458.

Place a copy of either of the above inside the shipping container and attach it physically to the material being returned. A copy of your packing list should be placed inside an envelope and attached to the outside of the shipping container or placed inside the container.

Failure to follow the above procedures could possibly result in considerable delay due to improperly or totally unidentified items.

2-4 Recommended Procedures

Prior to installation of the meter, the following items of general information and recommendations should be considered:

1. On new installations, the lines should be flushed thoroughly to rid the pipe of welding bead, pipe scale, etc., before the meter is placed in service. This can be done by using a spool-piece in place of the meter.
2. All counters can be rotated and secured in any of eight positions.
3. Flow direction is marked on the meter case, near the inlet flange.
4. Install a strainer ahead of the inlet of the meter.
5. The meter may be mounted either horizontally or vertically.
6. Shut-off or control valves should be located downstream of the meter.
7. Do not use guide wires or stabilizing ropes on any part of the stack-up. Some stack-ups will require support by use of support blocks and brackets secured to structural members.
8. Block valves located upstream and downstream of the meter are recommended to isolate the meter from fluid flow.

Section 3 OPERATION

CAUTION: Do not operate this meter in excess of the values listed in Section 1-4 Specifications.

3-1 General

1. When the meter is first put into operation, or at any time the meter has been drained, it should be started slowly until all air has been exhausted from the outer housing.
2. To prevent high shock pressures or surges, care should be exercised in opening or closing valves when starting or stopping flow through the meter.
3. On new installations, the lines should be flushed thoroughly to rid the pipe of welding bead, scale, etc., before the meter is placed in service. This can be done by using a spool-piece in place of the meter.
4. If the meter has been installed before the flushing operation, then the measuring unit should be removed from the outer housing while the line is being flushed.

Note: Failure to perform the above procedures could result in serious damage to the meter.

Water should never be used as a flushing medium through this meter. Always use a flushing medium that is compatible with the metallurgy of the meter and its internal parts, and similar to the product for which this meter was intended. See Materials of Construction Page 3.

5. A strainer of proper size should be installed upstream of the meter to protect it from the entrance of foreign material which might damage the measuring unit.
6. A regular schedule should be set up to clean the strainer basket to prevent air from filling and rupturing the screen. Pressure gauges installed on either side of the strainer will show the differential pressure across the strainer. High differential pressure may cause the basket to rupture, permitting large quantities of foreign matter to enter the meter suddenly. This would result in stoppage of the meter and require it to be disassembled and cleaned.

Section 4 MAINTENANCE

CAUTION: Extreme care must be exercised when the measuring chamber is exposed and handled. Hands must be kept clear of the timing gears, rotors and measuring chamber or serious personal injury can occur. Due to the precision balance of the rotors and timing gears, they can be set in motion easily. Keep hands clear of these parts at all times! At no time should hands be used to brace these parts while servicing.

4-1 General

The amount of maintenance necessary for efficient meter performance depends upon such factors as:

1. Continuity of Operation - A meter which operates almost continuously, obviously will require more attention than one on intermittent duty.
2. Rate of Flow - The practical life of any piece of equipment is proportional to its speed of operation. A meter operating at, or close to its maximum rating will naturally have a shorter life than one operating at a reduced rate.
3. Lubricating Value of Product - Other factors being equal, a meter handling a light lubricating oil will have a longer life than one measuring a dry motor fuel.
4. Cleanliness of Product - Abrasive solid matter accelerates meter wear.

Meters that are given a little attention regularly will deliver better performance and have a longer life than those that are given no attention until they have failed. Frequently a meter's performance will depend, to a considerable extent, upon the proper functioning of the accessory equipment in the piping system. Following are listed some of the conditions and factors influencing meter performance:

1. A meter should be kept filled with the liquid it is measuring. Draining results in the formation of deposits and gums which increase the mechanical friction. Any leaky shut-off valves or check valves which would permit the meter to drain should be repaired or replaced.
2. A petroleum meter should be kept free of water. Usually, regular inspection and draining of storage tanks is sufficient protection.
3. Clean the strainer basket frequently.
4. Soft closing loading valves or shock chambers for eliminating water hammer should be kept in good working order.
5. The valves and operating mechanism of an air eliminator should be given occasional inspection. This is especially true where a critical air condition exists and for this reason, meter performance is very dependent upon proper air elimination. The valves and operating mechanism of an air eliminator are subject to very difficult operating conditions. With some products alternate wetting and drying results in gum formations. The vapors of most petroleum products are more

corrosive than the liquids. In some installations salt air is a corrosive factor.

6. The counter of the meter should be given some protection during extreme weather conditions.
7. A meter taken out of service for any length of time should be filled with light lubricating oil.
8. Keep Brodie Meter Co., LLC service bulletins available for reference.

CAUTION: Before performing any disassembly or reassembly procedures, all flow to meter should be off. All electrical connections to accessories should be disconnected. Service should be performed by trained and qualified personnel only.

4-2 Removal of Measuring Unit (Reference Figure 6-1)

1. Remove drain plugs (item 16), drain meter and replace plug.
2. Remove all accessories, including adjuster (item 7) and counter base plate (item 4) by removing screws (items 6 and 8) and gasket (item 5).
3. Remove meter from line to allow for further disassembly.
4. Turn the meter on end, to rest on the inlet flange.
5. Remove nuts and bolts (items 9 and 12) and lift off the outlet housing (item 13).
6. Remove O-Ring (item 11) and inspect for nicks, cuts and excess wear. Replace as needed.
7. The measuring unit (item 10) may now be removed and inspected. In some cases a thorough washing in cleaning solvent or kerosene will be sufficient to free the rotors of corrosion or foreign material and the unit may be reinstalled without further disassembly. In the event the rotors are blocked with solid matter, it will be necessary to remove the rotors and gear box assembly for further cleaning.

CAUTION: Extreme care must be exercised when the measuring unit assembly is exposed or handled. Hands must be kept clear of all gears and rotors or serious personal injury can occur. Due to the precision of the rotors and drive gears, they can be set in motion easily. Keep hands clear of these parts at all times. At no time should the hands be used to brace the parts while servicing.

4-3 Disassembly on Measuring Unit (Reference Figure 6-2)

1. Position the Measuring Unit Assembly in a wooden support block with the gear assembly downward.
2. Block Rotors with a plastic or wooden rod, Figure 4-1.
3. Remove retaining ring (item 8) and washer (item 9) from driven gear assembly (item 10).
4. Remove driven gear (item 10) and gear shaft (item 11).
5. Remove set screw (item 7) from the drive gear (item 6). Lift off drive gear.
6. Remove adjustment nuts (item 3) from rotor shafts, and bearing retainers (item 4). Do not remove front end plates at this time.

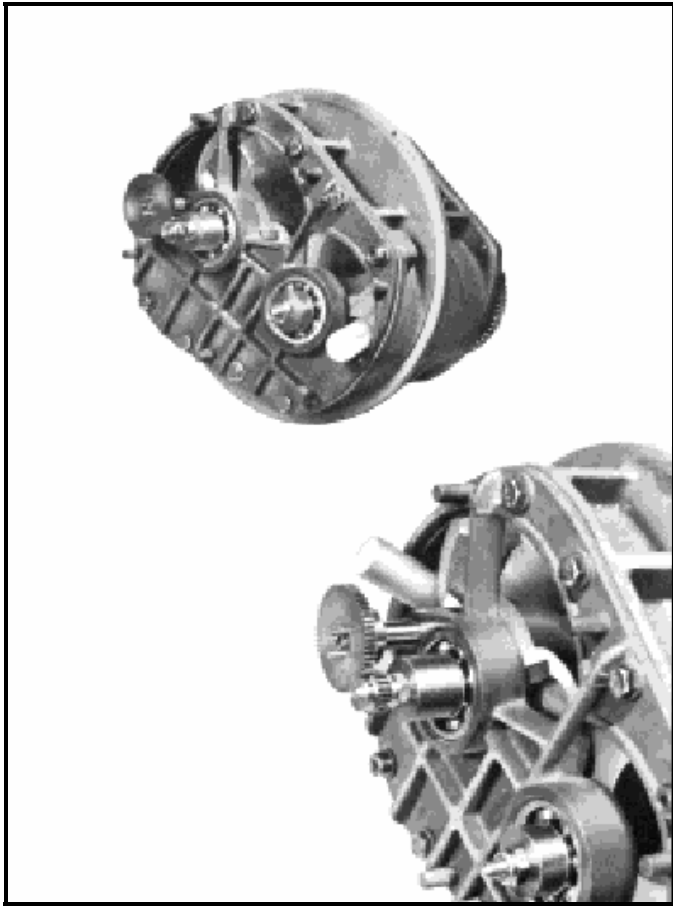

Figure 4-1 Blocking Rotors

7. Rotate measuring unit body (item 13) so that the front of the housing rests on wooden support blocks and the gear assembly is upward.
8. Remove timing gears from each rotor shaft by removing jam nuts (item 18) and lockwashers (item 19). To aid in removal, lightly tap the gears on a flat surface with a plastic or rubber mallet.

NOTE: Avoid hitting the teeth of the gears (item 4 & 8). The center hole of each timing gear is a tapered bore which fits the tapered end of the rotor shafts. Tapping the gears will break the "taper lock" and release the gears from the rotor shaft.

9. Remove the rotor spacer (item 16) used to separate the timing gears from the end plate (item 12).
10. Remove screws (item 14 & 15) and lift off the end plate.
11. The rotors, (items 20 & 23) and timing gears (17 & 24) can now be washed thoroughly with cleaning solvent or kerosene and inspected. If the rotors show no evidence of contact with each other, and the timing gears appear satisfactory, further disassembly will not be necessary. To completely disassemble go on to step 12.

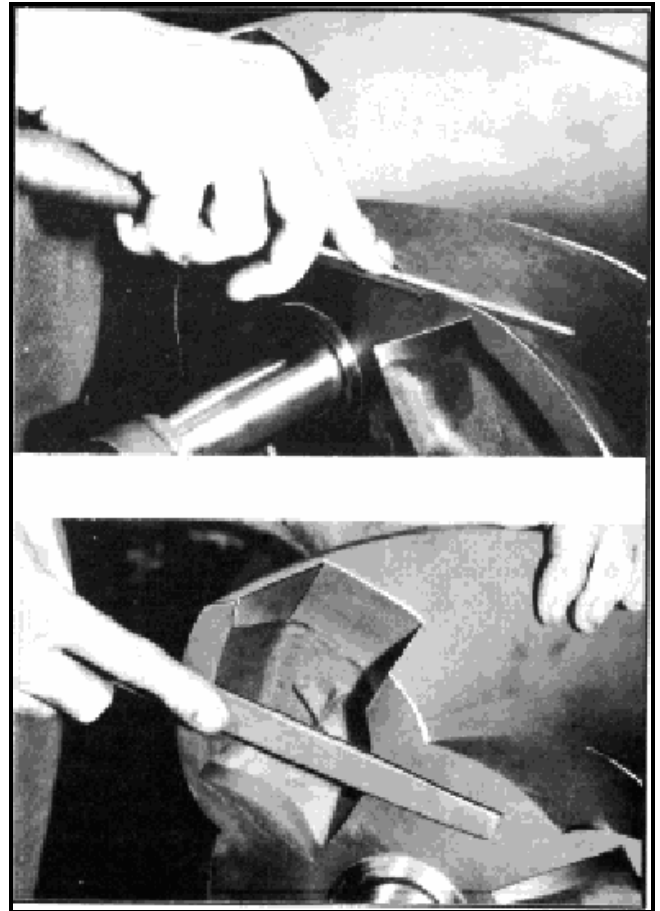

Figure 4-2 Filing Rotors

12. Ball bearings (item 21) can be removed from the end plate by gently tapping or pressing on the inner race of the bearings from inside the end plate.
13. Remove the two rotors (items 20 & 23) from the measuring unit body.
14. To completely disassemble, rotate the body and remove the end plate and bearings as described in steps 10 and 12.

4-4 Cleaning Measuring Unit (Refer to Figure 4-2)

1. Scored metal should be removed with a scraper or file. Remove only the high points and do not remove any more metal than necessary.
2. Polish rotors with crocus cloth and wash carefully in solvent or kerosene to remove all particles of grit or metal.
3. File lightly the end plates (item 12) to remove any burrs or high spots. Use fine sandpaper to remove corrosion and burrs from the surface of the bores that carry the bearings.
4. Ball bearings should be cleaned and inspected for wear. Excessive wear dictates the need for bearing replacement.
5. All gears and shafts in the gear assembly should be inspected. Check all O-Rings for wear and replace if necessary.

4-5 Reassembly- Measuring Unit

1. Lubricate all bearings and O-Rings with a light weight oil.
2. Oil dowel screws (item 14) and replace front end plate (item 12) on opposite end from timing gears. Replace screws (item 15).
3. Rotate the housing body and replace rotors (items 20 & 23) in their proper slots with the taper ends of the rotor shafts up.
4. Replace rear end plate (item 12). Oil dowel screws (item 14) and screws (item 15) before replacing.
5. Install bearings (item 21) into bearing bore of end plate (item 12).

NOTE: Slot on the outer race of the ball bearing must engage with the roll pin (item 12) in the end plate.

6. Replace rotor spacers (item 16) and timing gears (items 17 & 24).

NOTE: The bearing dowel on the rotor spacer fits on the inner race of the ball bearing and outer dowel must seat into the slot located on the timing gear.

NOTE: The large timing gear (item 24) fits on the 4T rotor (item 23) and the small timing gear (item 17) fits on the 3T rotor (item 20).

7. Replace lockwashers (item 19). Tab on the washers must fit into slot on the timing gears.
8. Replace jam nuts (item 18).
9. Rotate the body (item 13) and replace the front end plate (item 12) using lightly oiled dowel screws (item 14) and screws (item 15).
10. Replace bearings as described in step 5 and lock in place with bearing retainers (item 4).
11. Lock rotors into place using adjustment nuts (item 3).
12. Reassemble driven gear shaft (item 11) driven gear (item 10), washer (item 9) and the retaining ring (item 8).
13. Return the drive gear (item 6) to its original position and secure with set screw (item 7).

4-6 Timing Gear Adjustment

1. Loosen the nut (item 18) on the large timing gear (item 24) and with a feeler gauge, carefully centralize lobe of the 3T rotor in a flute of the 4T rotor. This may be done through the inlet and outlet of the unit.
2. Using a small piece of rubber between the timing gears, tighten the jam nut (item 18). Remove the feeler gauge and check for freeness of operation. If the rotors contact one another the timing operation must be repeated. If the rotors were damaged, it will sometimes be found that all of the high spots were not removed. In such cases, it is necessary to find these spots and remove them.

4-7 Adjusting End Clearance

The following is applicable if clearance between the rotors and end plate requires adjustment.

1. Loosen the adjustment nuts (item 3) on the front rotor shaft and tighten the adjustment screws (item 22) of on the outlet side pushing the rotors against the front plate.
2. Determine the clearance between the rotors and rear end cover with a feeler gauge. For example .0008.
3. Adjust the rotors to one-half the measured clearance or .0004 of the above example and adjust nuts (items 3 & 18) and adjustment screws (item 22) accordingly.

4-8 Completion of Measuring Unit Reassembly

1. Lower the assembled measuring unit onto the outlet housing (item 13) and lightly oil the O-Ring (item 11).
2. Position O-Ring (item 11) and inlet housing (item 1) into place and secure with screws and nuts (items 9 & 12).
3. Rotate the coupling tube on the pinion shaft assembly of the counter base plate assembly (item 4) until the drive pin is positioned the same as the slot of the coupling jaw on the driven gear (item 10, Figure 6-2).
4. Reinstall other accessories.

Section 5 TROUBLESHOOTING

Table 5-1 has been provided to aid in basic troubleshooting. Disassembly procedures are covered in Section 4 Maintenance. If the flowmeter is found to be in need of repair, it is recommended the user contact the nearest Service or Sales Office. It is important that servicing be performed by trained and qualified service personnel.

Table 5-1 TROUBLESHOOTING

Symptom	Possible Cause	Service Required
Meter runs but counter does not register.	Faulty Register	Remove register and see if output shaft on adjustor rotates with metered fluid flow. If output shaft on adjustor rotates, replace register.
	Faulty adjustor or broken coupling between adjustor and counter base plate.	Remove adjustor and see if output shaft on counter base plate rotates with metered fluid flow. If output shaft of counter baseplate assembly rotates, then inspect the following: 1. Check coupling on input shaft of adjustor to see if it's broken. If broken, replace coupling. 2. If coupling is not broken, replace adjustor.
Meter runs but is noisy	Meter is not timed properly.	Check rotor clearances as described in section 4-7. If discrepancy is found, retim rotors.
	Damaged Rotors	Remove rotors as described in section 4-3. If rotors are scored or galled, clean them as described in section 4-4. If rotors are damaged beyond repair, replace with a new set. Install rotors as described in section 4-5.
	Worn ball bearings.	Remove ball bearings as described in section 4-3. Check to see if ball bearings turn freely with no free play. If discrepancy is found, replace ball bearings and install as described.
	Damaged gears in counter	Disassemble counter base plate assembly. Check for worn or damaged gears. Replace gears as necessary and reassemble base plate assembly.

Section 6 PARTS LIST

6-1 General

This section contains the necessary parts required to make up any standard unit that is covered in this bulletin. Each parts list also contains the recommended spare and replacement parts denoted by an asterisk. For items that are not listed, or additional information consult factory.

When ordering, the following information must be furnished:

1. Part number and description
2. Model number of flowmeter
3. Serial number of flowmeter
4. Quantity required

When ordering items of a material or special construction not indicated in the Parts List, furnish the following information so that the part number of the item can be determined.

1. Item number and description
2. Specific material of item
3. Model number of flowmeter
4. Serial number of flowmeter
5. Quantity required

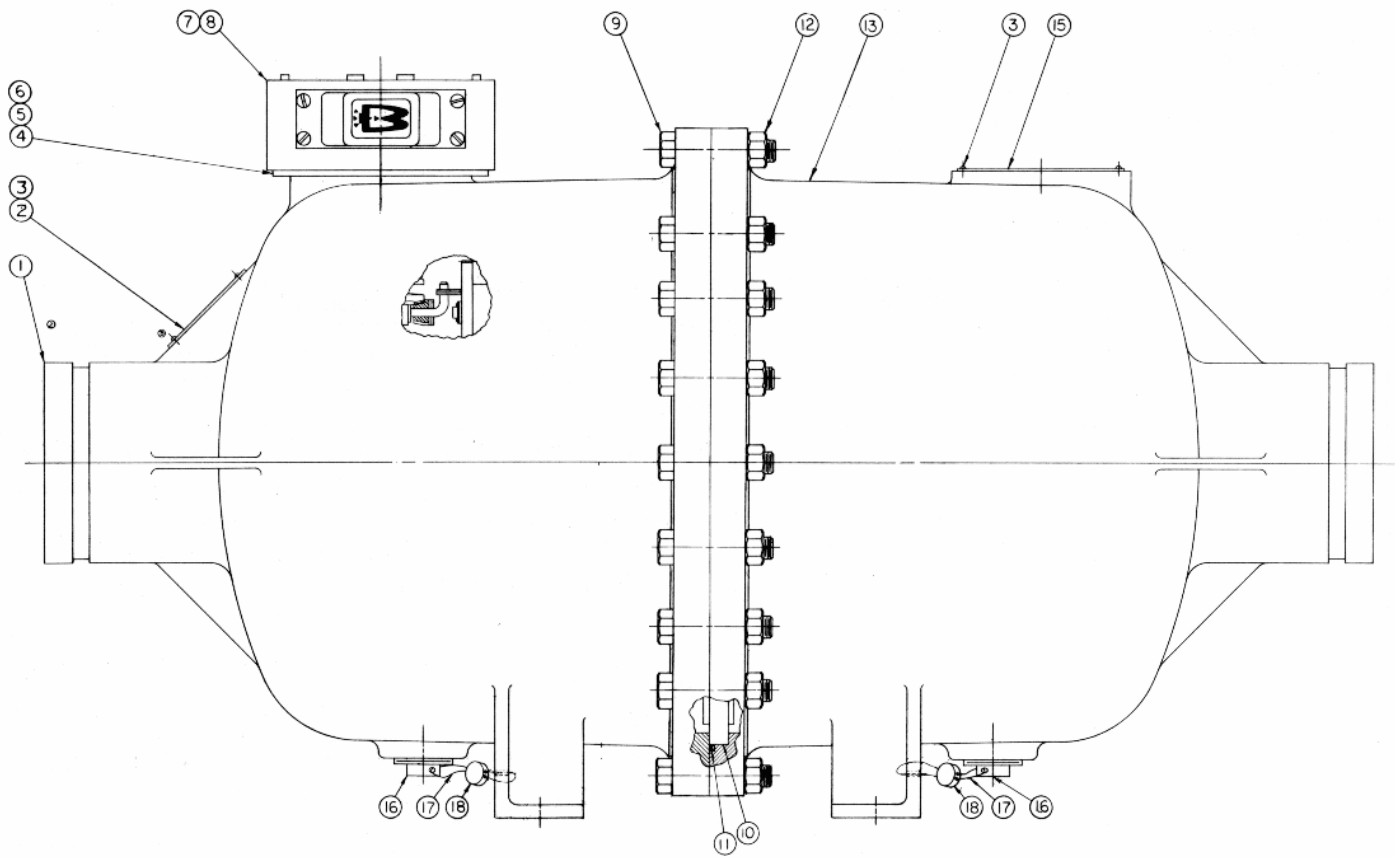

Figure 6-1 Complete Meter Assembly

Table 6-1 Complete Meter Assembly - Parts List

Item	Description	Req.	Part Number
1	Inlet Housing	1	82445
2	Inlet Plate	1	782-16-181 -00
3	Drive Screw	2	153971
4	Counter Base Plate	1	80750-100
5*	Gasket	1	51156
6	Screw	9	151253
7	Adjustor	1	4200
8	Screw	4	150565
9	Bolt	22	150806
10	Meas. Unit Assy.	1	80505-010
11*	O-Ring	1	157351-021
12	Nut	22	151555
13	Outlet Housing	1	82555
14	Drive Screw	4	153991
15	Name Plate	1	60802
16	Pipe Plug 1 " NPT Alum	2	154718-124
17	Seal Wire	2	155051
18	Lead Seal	2	151831

*Recommended Spare Parts

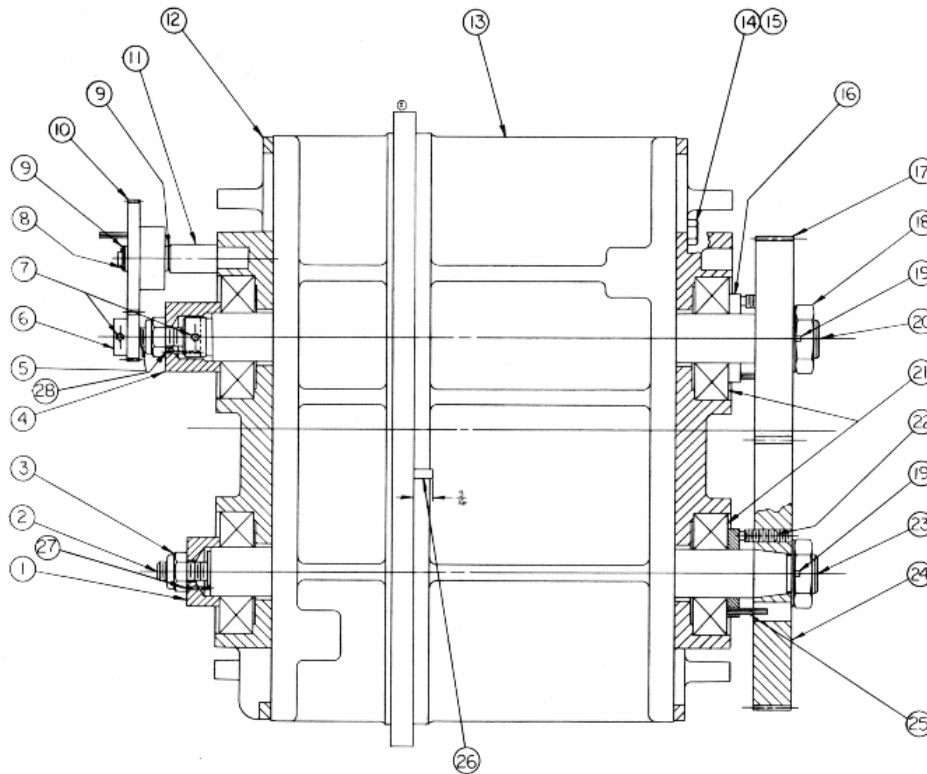

Figure 6-2 Complete Measuring Unit Assembly

Table 6-2 Complete Measuring Unit Assembly - Parts List

Item	Description	Req.	Part Number
1	Bearing Retainer	1	80603
2	Stud - 3/8- 16 x 2 St. Stl.	1	151370
3	Adjustment Nut	2	151663
4	Bearing Retainer	1	80604
5	Drive Shaft	1	80579
6	Drive Gear	1	89541
7	Set Screw - 8-32 x 3/16 St. Stl.	3	150975-419
8	Retaining Ring	1	153953-019
9	Washer	2	151901
10	Driven Gear Assy.	1	89525
11	Gear Shaft	1	80527
12	End Plate	1	82516
13	Rotor Body	1	82506
14	Dowel Screw	1	92567
15	Hex HD Cap Screw 3/8 - 16x1	12	150766-419
16	Rotor Spacer	1	80294
17	3 Tooth Timing Gear	1	80291
18	Nut	2	83592
19	Lockwasher	2	82593
20	3 Tooth Rotor	1	82276
21	Ball Bearing	4	154951-100
22	Adjustment Screw	4	150987
23	4 Tooth Rotor	1	82286
24	4 Tooth Timing Gear	1	80296
25	Roll Pin	2	153554
26	Groove Pin	1	153645

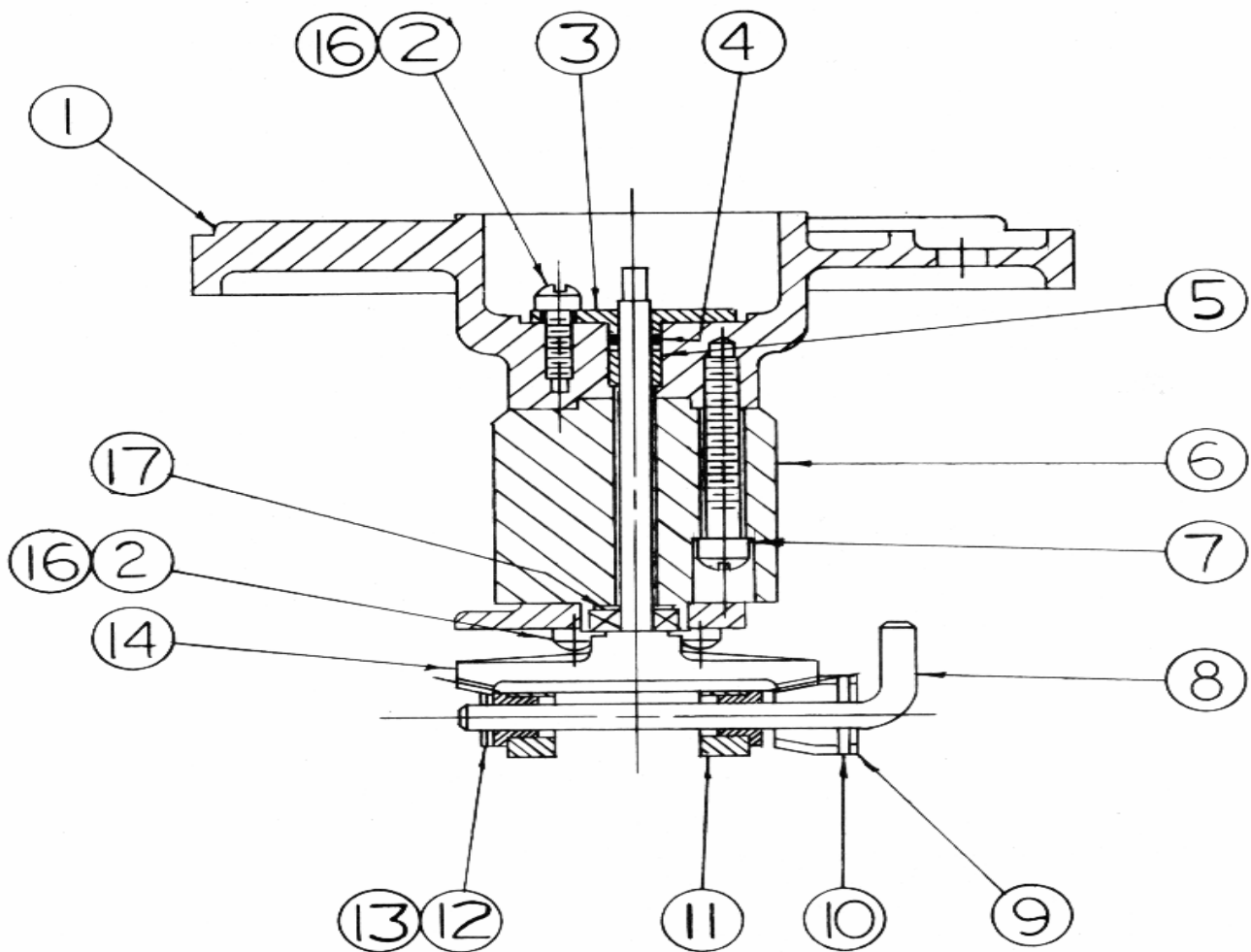

Figure 6-3 Counter Base Plate Assembly

Table 6-3 Counter Base Plate Assembly - Parts List

Item	Description	Req.	Part Number
1	Ctr. Base Plate	1	72751-100
2	Screw	6	150472
3	Packing Gland	1	52153-100
4*	O-Ring	1	152064-114
5	Bushing	1	155142
6	Mounting Rack	1	80761
7	Screw	3	150463-019
8	Pinion Shaft	1	89153
9	Pinion	1	51769-200
10	Roll Pin	1	153549
11	Bearing Brkt.	1	51760-500
12	Retainer Ring	1	156484
13	Washer	2	151891
14	Packing Shaft Assy.	1	89785-200
16	Lockwasher	6	15257-019
17	Ball Bearing	1	155195

*Recommended Spare Parts

LIMITED WARRANTY

Seller warrants that the Goods manufactured by Seller will be free from defects in materials or workmanship under normal use and service until the expiration of the earlier of twelve (12) months from the date of initial installation or eighteen (18) months from the date of shipment by Seller. Consumables, including, without limitation, glass parts and electrodes, membranes, liquid junctions, electrolytes and reagents, o-rings, plastic tubing, etc. are warranted to be free from defects in material and workmanship under normal use and service for a period of ninety (90) days from the date of shipment by Seller. If, within thirty (30) days after Buyer's discovery of any warranty defects during the applicable warranty period, Buyer notifies Seller thereof in writing, Seller shall, at its option, promptly correct any errors that are found by Seller to exist in the Software, or repair or replace F.O.B. point of manufacture, that portion of the Goods or Software found by Seller to be defective. All replacements or repairs necessitated by inadequate preventive maintenance, or by normal wear and usage, or by fault of Buyer, or by unsuitable power sources or by attack or deterioration under unsuitable environmental conditions, or by abuse, accident, alteration, misuse, improper installation, modification, repair, storage or handling, or any other cause not the fault of Seller are not covered by this limited warranty, and shall be at Buyer's expense. Seller shall not be obligated to pay any costs or charges incurred by Buyer or any other party except as may be agreed upon in writing in advance by an authorized Seller representative. All costs of dismantling, reinstallation and freight and the time and expenses of Seller's personnel for site travel and diagnosis under this warranty clause shall be borne by Buyer unless accepted in writing by Seller. Goods repaired and parts replaced during the warranty period shall be in warranty for the remainder of the original warranty period or ninety (90) days, whichever is longer. This limited warranty is the only warranty made by Seller and can be amended only in a writing signed by an authorized representative of Seller. There are no representations or warranties of any kind, express or implied, as to merchantability, fitness for particular purpose, or any other matter with respect to any of the goods or software.