



## Brodie customer service

Phone:

Compact Prover Support: Toll free +1 888-849-1481  
Brodie switchboard (general enquiries): +1 912-489-0200

Email:

Compact Prover support: [compact-prover@brodieintl.com](mailto:compact-prover@brodieintl.com)  
Customer Service (spare parts orders): [cos@brodieintl.com](mailto:cos@brodieintl.com)

## Signal words and symbols

Pay special attention to the following signal words, safety alert symbols and statements:

### **SAFETY ALERT SYMBOL**

This is a safety alert symbol. It is used to alert you to potential physical injury hazards. Obey all safety messages that follow this symbol to avoid possible injury or death.

### **DANGER**

Danger indicates a hazardous situation which, if not avoided, will result in death or serious injury.

### **WARNING**

Warning indicates a hazardous situation which, if not avoided, could result in death or serious injury.

### **CAUTION**

Caution indicates a hazardous situation which, if not avoided, could result in minor or moderate injury.

### **NOTICE**

Caution indicates a hazardous situation which, if not avoided, could result in minor or moderate injury.

### **IMPORTANT**

Important is a statement the user needs to know and consider.

### **TIP**

Tip provides information or suggestions for improved efficiency or best results.

### **NOTE**

Note is a “general by-the-way” content not essential to the main flow of information.

## Important safety instructions

Brodie International, LLC (Brodie) designs, manufactures and tests products to function within specific conditions. Because these products are sophisticated technical instruments, it is important that the owner and operation personnel strictly adhere both to the information printed on the product and to all instructions provided in this manual prior to installation, operation, and maintenance.

Brodie also urges you to integrate this manual into your training and safety program.

### **BE SURE ALL PERSONNEL READ AND FOLLOW THE INSTRUCTIONS IN THIS MANUAL AND ALL NOTICES AND PRODUCT WARNINGS.**

Installing, operating or maintaining a Brodie product improperly could lead to serious injury or death from explosion or exposure to dangerous substances. To reduce this risk:

- Comply with all information on the product, in this manual, and in any local and national codes that apply to the product.
- Do not allow untrained personnel to work with this product.
- Use Brodie parts and work procedures specified in this manual.

### **Product owners (Purchasers):**

Use the correct product for the environment and pressures present. See technical data or product specifications for limitations. If you are unsure, discuss your needs with your Brodie representative. Inform and train all personnel in the proper installation, operation, and maintenance of this product. To ensure safe and proper performance, only informed and trained personnel should install, operate, repair and maintain this product.

Verify that this is the correct instruction manual for your Brodie product. If this is not the correct documentation, contact Brodie at +1 888-849-1481. You may also download the correct manual from:

<http://www.brodieintl.com>

- Save this instruction manual for future reference.
- If you resell or transfer this product, it is your responsibility to forward this instruction manual along with the product to the new owner or transferee.
- ALWAYS READ AND FOLLOW THE INSTALLATION, OPERATIONS, MAINTENANCE AND TROUBLESHOOTING MANUALS AND ALL PRODUCT WARNINGS AND INSTRUCTIONS.
- Do not use this equipment for any purpose other than its intended service. Not following this guideline may result in property damage and/or serious personal injury or death.

### **Product Operation Personnel:**

- To prevent personal injury, personnel must follow all instructions of this manual prior to and during operation of the product.
- Follow all warnings, cautions, and notices marked on, and supplied with, this product.
- Verify that this is the correct instruction manual for your Brodie product. If this is not the correct documentation, contact Brodie at +1 888-849-1481. You may also download the correct manual from:

**<http://www.brodieintl.com>**

- Read and understand all instructions and operating procedures for this product.
- If you do not understand an instruction, or do not feel comfortable following the instructions, contact your Brodie representative for clarification or assistance.
- Install this product as specified in the INSTALLATION section of this manual per applicable local and national codes.
- Follow all instructions during the installation, operation, and maintenance of this product.
- Connect the product to the appropriate pressure and electrical sources when and where applicable.
- Ensure that all connections to pressure and electrical sources are secure prior to and during equipment operation.
- Use only replacement parts specified by Brodie. Unauthorized parts and procedures can affect this product's performance, safety, and invalidate the warranty. "Look-a-like" substitutions may result in deadly fire, explosion, release of toxic substances or improper operation.
- Save this instruction manual for future reference.

## Notice

THE CONTENTS OF THIS PUBLICATION ARE PRESENTED FOR INFORMATIONAL PURPOSES ONLY, AND WHILE EVERY EFFORT HAS BEEN MADE TO ENSURE THEIR ACCURACY, THEY ARE NOT TO BE CONSTRUED AS WARRANTIES OR GUARANTEES, EXPRESSED OR IMPLIED, REGARDING THE PRODUCTS OR SERVICES DESCRIBED HEREIN OR THEIR USE OR APPLICABILITY. ALL SALES ARE GOVERNED BY BRODIE'S TERMS AND CONDITIONS, WHICH ARE AVAILABLE UPON REQUEST. WE RESERVE THE RIGHT TO MODIFY OR IMPROVE THE DESIGNS OR SPECIFICATIONS OF SUCH PRODUCTS AT ANY TIME.

BRODIE DOES NOT ASSUME RESPONSIBILITY FOR THE SELECTION, USE OR MAINTENANCE OF ANY PRODUCT. RESPONSIBILITY FOR PROPER SELECTION, USE AND MAINTENANCE OF ANY BRODIE PRODUCT REMAINS SOLELY WITH THE PURCHASER AND END-USER.

TO THE BEST OF BRODIE'S KNOWLEDGE THE INFORMATION HEREIN IS COMPLETE AND ACCURATE. BRODIE MAKES NO WARRANTIES, EXPRESSED OR IMPLIED, INCLUDING THE IMPLIED WARRANTIES OF MERCHANTABILITY AND FITNESS FOR A PARTICULAR PURPOSE WITH RESPECT TO THIS MANUAL AND, IN NO EVENT, SHALL BRODIE BE LIABLE FOR ANY INCIDENTAL, PUNITIVE, SPECIAL OR CONSEQUENTIAL DAMAGES INCLUDING, BUT NOT LIMITED TO, LOSS OF PRODUCTION, LOSS OF PROFITS, LOSS OF REVENUE OR USE AND COSTS INCURRED INCLUDING WITHOUT LIMITATION FOR CAPITAL, FUEL AND POWER, AND CLAIMS OF THIRD PARTIES.

PRODUCT NAMES USED HEREIN ARE FOR MANUFACTURER OR SUPPLIER IDENTIFICATION ONLY AND MAY BE TRADEMARKS/REGISTERED TRADEMARKS OF THESE COMPANIES.

## Warranty and Limitations

1. **LIMITED WARRANTY:** Subject to the limitations contained in Section 2 herein, Brodie International (“Brodie”) warrants that the licensed firmware embodied in the Goods will execute the programming instructions provided by Brodie, and that the Goods manufactured by Brodie will be free from defects in materials or workmanship under normal use and care and Services will be performed by trained personnel using proper equipment and instrumentation for the particular Service provided. The foregoing warranties will apply until the expiration of the applicable warranty period. Goods are warranted for twelve (12) months from the date of initial installation or eighteen (18) months from the date of shipment by Brodie, whichever period expires first. Consumables and Services are warranted for a period of 90 days from the date of shipment or completion of the Services. Products purchased by Brodie from a third party for resale to Buyer (“Resale Products”) shall carry only the warranty extended by the original manufacturer. Buyer agrees that Brodie has no liability for Resale Products beyond making a reasonable commercial effort to arrange for procurement and shipping of the Resale Products. If Buyer discovers any warranty defects and notifies Brodie thereof in writing during the applicable warranty period, Brodie shall, at its option, correct any errors that are found by Brodie in the firmware or Services or repair or replace F.O.B. point of manufacture that portion of the Goods or firmware found by Brodie to be defective, or refund the purchase price of the defective portion of the Goods/Services. All replacements or repairs necessitated by inadequate maintenance, normal wear and usage, unsuitable power sources or environmental conditions, accident, misuse, improper installation, modification, repair, use of unauthorized replacement parts, storage or handling, or any other cause not the fault of Brodie are not covered by this limited warranty, and shall be at Buyer’s expense. Brodie shall not be obligated to pay any costs or charges incurred by Buyer or any other party except as may be agreed upon in writing in advance by Brodie. All costs of dismantling, reinstallation and freight and the time and expenses of Brodie’s personnel and representatives for site travel and diagnosis under this warranty clause shall be borne by Buyer unless accepted in writing by Brodie. Goods repaired and parts replaced by Brodie during the warranty period shall be in warranty for the remainder of the original warranty period or ninety (90) days, whichever is longer. This limited warranty is the only warranty made by Brodie and can be amended only in a writing signed by Brodie. **THE WARRANTIES AND REMEDIES SET FORTH ABOVE ARE EXCLUSIVE. THERE ARE NO REPRESENTATIONS OR WARRANTIES OF ANY KIND, EXPRESS OR IMPLIED, AS TO MERCHANTABILITY, FITNESS FOR PARTICULAR PURPOSE OR ANY OTHER MATTER WITH RESPECT TO ANY OF THE GOODS OR SERVICES.** Buyer acknowledges and agrees that corrosion or erosion of materials is not covered by this warranty.

2. **LIMITATION OF REMEDY AND LIABILITY:** Brodie SHALL NOT BE LIABLE FOR DAMAGES CAUSED BY DELAY IN PERFORMANCE. THE REMEDIES OF BUYER SET FORTH IN THIS AGREEMENT ARE EXCLUSIVE. IN NO EVENT, REGARDLESS OF THE FORM OF THE CLAIM OR CAUSE OF ACTION (WHETHER BASED IN CONTRACT, INFRINGEMENT, NEGLIGENCE, STRICT LIABILITY, OTHER TORT OR OTHERWISE), SHALL BRODIE’S LIABILITY TO BUYER AND/OR ITS CUSTOMERS EXCEED THE PRICE TO BUYER OF THE SPECIFIC GOODS MANUFACTURED OR SERVICES PROVIDED BY BRODIE GIVING RISE TO THE CLAIM OR CAUSE OF ACTION. BUYER AGREES THAT IN NO EVENT SHALL BRODIE’S LIABILITY TO BUYER AND/OR ITS CUSTOMERS EXTEND TO INCLUDE INCIDENTAL, CONSEQUENTIAL OR PUNITIVE DAMAGES. THE TERM “CONSEQUENTIAL DAMAGES” SHALL INCLUDE, BUT NOT BE LIMITED TO, LOSS OF ANTICIPATED PROFITS, REVENUE OR USE AND COSTS INCURRED INCLUDING WITHOUT LIMITATION FOR CAPITAL, FUEL AND POWER, AND CLAIMS OF BUYER’S CUSTOMERS.

# Contents

- Brodie customer service .....2
- Signal words and symbols.....3
- Important safety instructions .....4
- Notice.....6
- Warranty and Limitations .....7

**Section 1: Introduction**

- 1.1 General.....12
- 1.2 Description .....12
- 1.3 Mechanical description.....13
- 1.4 Technical data..... 16

**Section 2: Installation and set-up**

- 2.1 Installation .....21
- 2.2 Set-up.....23
  - 2.2.1 Supplying electrical power to the compact prover.....23
  - 2.2.2 Connection of the operating computer .....24
  - 2.2.3 12 or 24V DC Interface Board..... 26
  - 2.2.4 Charging the Pneumatic Spring Plenum ..... 29
- 2.3 Base volume certification ..... 30
- 2.4 Calibration integrity seal installation procedure.....31

**Section 3: Operation**

- 3.1 General operational theory.....32
- 3.2 Operating instructions.....35

**Section 4: Maintenance**

- 4.1 Seal Leak Check ..... 39
- 4.2 Base volume determination ..... 41
  - 4.2.1 Certification techniques..... 41
  - 4.2.2 Water draw procedure: (Reference Figure 4-4 and notes on page 50)..... 45
- 4.3 Certification Data Sheet and Calculations..... 52
  - 4.3.1 Data Sheet Entries..... 52
  - 4.3.2 Calculations ..... 53
- 4.4 Seal Replacement..... 55
  - 4.4.1 Measurement Piston and Flow Tube ..... 55
  - 4.4.2 Optical Seal Support..... 63
  - 4.4.3 Hydraulic Cylinder and Hydraulic Seal Support..... 66
- 4.5 Optical conversion kit ..... 70
- 4.6 Detector Switch Replacement .....71

<b>Section 5: Troubleshooting</b>	
5.1 General .....	75
5.2 Interface Signals .....	75
5.3 Measurement Piston Movement.....	77
5.4 The auto plenum adjust panel .....	82
<b>Section 6: Special tools and equipment</b>	
6.1 Tool list .....	86
<b>Section 7: Parts list</b>	
7.1 General .....	89
7.2 Replacement Parts List.....	89

# List of Tables

- Table 1-1 Hydraulic .....17
- Table 1-2 Standard compact prover set-up data ..... 18
- Table 1-3 Power requirements ..... 19
- Table 3-1 Spring plenum 'R' values.....35
- Table 4-1 Torque table ..... 58
- Table 4-2 Tie rod nut torque..... 60
- Table 4-3 Hydraulic cylinder tie rod nut torque..... 70
- Table 4-4 Volumetric percent change for compact provers..... 74
- Table 6-1 Tool size requirement ..... 87
- Table 6-2 Torque values for pipe flange stud/nut sets..... 88
- Table 7-1 Parts list ..... 90
- Table 7-2 Compact Prover Model Code ..... 99

# List of Figures

Figure 1-1 Outline drawings - Compact prover .....	15
Figure 2-1 Typical prover installation.....	23
Figure 2-2 Double chronometry .....	25
Figure 2-3 12/24V Prover interface board.....	27
Figure 2-4 12/24V Prover interface board .....	28
Figure 2-5 Typical nitrogen adjust panel.....	29
Figure 2-6 Connection diagram.....	30
Figure 1A Integrity Seal .....	31
Figure 3-1 Standby position .....	32
Figure 3-2 Initial motion.....	33
Figure 3-3 Proving .....	33
Figure 3-4 End of proving run.....	34
Figure 3-5 Piston returning to upstream position .....	34
Figure 3-6 Spring plenum .....	35
Figure 3-7 Hydraulic system.....	37
Figure 4-1 Leak detector kit.....	39
Figure 4-2 Leak detector kit installed .....	40
Figure 4-3 Compact prover water draw assembly typical NEC style (non-explosion proof).....	40
Figure 4-3 Compact prover water draw assembly (continued) Typical Ex-proof style .....	44
Figure 4-4 Water draw system.....	45
Figure 4-5 Test measure temperature stabilization .....	48
Figure 4-6 Typical volumetric determination data sheet.....	51
Figure 4-7 Typical prover control panel assembly (12" shown).....	52
Figure 4-8 Poppet O-ring installation .....	57
Figure 4-9 Optical seal support assembly 8" thru 18" & 24" units built prior to January 1, 2006.....	64
Figure 4-10 Optical seal support assembly - 24" (built after January 1, 2006) and 34" .....	65
Figure 4-11 Hydraulic seal support assembly.....	66
Figure 4-12 Typical hydraulic cylinder assembly .....	68
Figure 4-13 Detector switch removal #1.....	71
Figure 4-14 Detector switch removal #2 .....	72
Figure 4-15 Detector switch adjustment.....	73
Figure 5-1 Prover signal timing .....	76
Figure 5-2 Prover wiring diagram (single phase power).....	78
Figure 5-3 Prover wiring diagram (three phase power).....	79
Figure 5-4 Prover wiring diagram (ATEX and IECEx internal) .....	80
Figure 5-5 Prover wiring diagram (ATEX and IECEx external).....	81
Figure 5-6 DC powered solenoids .....	84
Figure 5-7 AC powered solenoids .....	85
Figure 7-1 Spare parts diagram (flow tube).....	95
Figure 7-2 Spare parts diagram (Flow tube) (continued).....	96
Figure 7-3 Spare parts diagram (Mechanical components) .....	97
Figure 7-4 Spare parts diagram (Electrical components) .....	98

# Section 1: Introduction

## 1.1 General

This manual is designed to provide information and guidance to personnel responsible for the operation and maintenance of the Compact Prover. The content of this manual is intended to describe the normal operational characteristics of the Compact Prover. By necessity, this manual is written for standard provers. It does not include specific information pertinent to specially designed items or non-standard equipment. Operating and Maintenance Instructions for special equipment will be supplied as necessary.

The Compact Prover is not a stand-alone system. The prover requires the use of an operating computer that is capable of Dual Chronometry Pulse Interpolation. The operating computer will process and summarize all proving data. Refer to the Operation section of this manual for more information.

## 1.2 Description

The Compact Prover provides improved accuracy, rapid operation and continuous flow for performance testing, or 'proving', of liquid flow meters in an operational line. Modern electronics permit exact time determination and pulse counting, which provides high accuracy proving with a smaller volume and fewer flowmeter pulses than any previous proving technology.

Because of its reduced size and a unique patented piston design, which includes an internal poppet valve, the Compact Prover can be easily installed in most operational lines and operated with minimal disturbance to flow. The prover's internal design incorporates an inherent fail-safe feature constructed to assure uninterrupted liquid flow.

The Interface Enclosure contains a printed circuit board which conditions the signals generated by the prover. The operating computer, which is typically located in a control room, receives these signals and generates data from the proving passes. This data can be printed for manual implementation to the process line flow meter. Some proving applications can be programmed for automatic implementation.

A typical proving run should generate the following raw data:

1. The exact time interval, in seconds, for the certified volume of the prover to be displaced.
2. The exact time interval, in seconds, to tabulate flow meter pulses.
3. The exact number of whole meter pulses generated by the liquid displaced during the proving run.

Typical data given by the operating computer include:

- Frequency: Flowmeter pulses/second, Hz
- Flow rate: Units of volume/minute or hour (Can be GPM, BPH, LPM or M3/HR)
- K-Factor: Flowmeter pulses/unit of volume
- Meter Factor: Correction factor (multiplier) for meter readout

## 1.3 Mechanical Description

The basic outline of the compact prover and its component parts are shown in [Figure 1-1](#). The compact prover consists of a free flowing measurement piston and a coaxial mounted poppet valve, all within a precision flow tube. The poppet valve is incorporated within the measurement piston and is connected to the hydraulic cylinder by way of an actuator shaft. A calculated pressure in the pneumatic spring plenum, in combination with the hydraulic system, operates the actuator piston within the hydraulic cylinder. The pressure in the pneumatic spring plenum closes the poppet valve, allowing the piston to proceed through a proving pass. Once the pass is complete, the hydraulic system returns the piston to the upstream (standby) position while holding the poppet valve open. Normal flow of the liquid will pass through the open poppet valve. Optical sensors are used to detect the position of the piston inside the flow tube. These sensors generate position signals, which are used for proper operation and data calculation. Refer to [Section 3: Operation](#) for complete operation instructions.

### Flow Tube

The flow tube is a stainless steel tube with a precision machined, hard chrome-plated bore. It contains the prover piston, poppet valve, and fail-safe mechanism.

### End connections:

The inlet and outlet end connections for installing the compact prover in line are ANSI 16.5 raised face flanges. Reference [Section 1.4](#) for Technical data.

### Hydraulic cylinder

The hydraulic cylinder contains the actuator piston to act as a barrier between the gas in the pneumatic spring plenum and the hydraulic oil. It provides the forces necessary to open and close the poppet valve and to operate the prover through its cycle. Connected to the actuator piston is the actuator shaft, which is connected to the poppet on the opposite end.

### Optical assembly

This intrinsically safe component is precision designed for accurate volume measurement within 5 ten thousandths (0.0005) of one inch or 0.0127 mm. There are three optical sensors (switches) used: one for the upstream (standby) position, and two for defining the displaced volume of fluid flowing through the prover. These slotted switches have an infrared LED and a phototransistor on opposite sides of the slot. The prover generates a signal when a "flag" passes through the slot and blocks the infrared light from the phototransistor. The flag is attached to the measurement piston by means of the detector shaft. The passage of the flag through the slotted optical switches defines the displaced volume (base volume) of the prover. For detailed information on the Optical Assembly, see [Section 4: Maintenance](#).

### Hydraulic control valve

This normally closed two-way valve controls the hydraulic operation of the prover. The valve is energized to open during a proving pass, and de-energized to close for the piston return to the upstream (standby) position. There are two styles of control valve used. Style is dependent upon prover size and electrical system (NEC or ATEX and IECEx Type). See Figure 1-1.

### Hydraulic pump

The hydraulic pump is a variable displacement vane-type unit driven by an electric motor. It supplies the power necessary to overcome the plenum pressure and return the piston upstream. Once the piston has reached the upstream position, the pump assumes a neutral condition maintaining hydraulic pressure at no flow for minimum power consumption.

### Pneumatic spring plenum

The charge of pressurized gas in the pneumatic spring plenum supplies the energy necessary to overcome the shaft seal friction and close the poppet valve. A portion of the charge is required to overcome the force generated by the product pressure within the prover acting on the actuator shaft and the detector shaft. When properly adjusted, this charge allows for minimum pressure differential (usually only a few inches of water column) across the piston.

Figure 1-1 Outline drawings - Compact prover

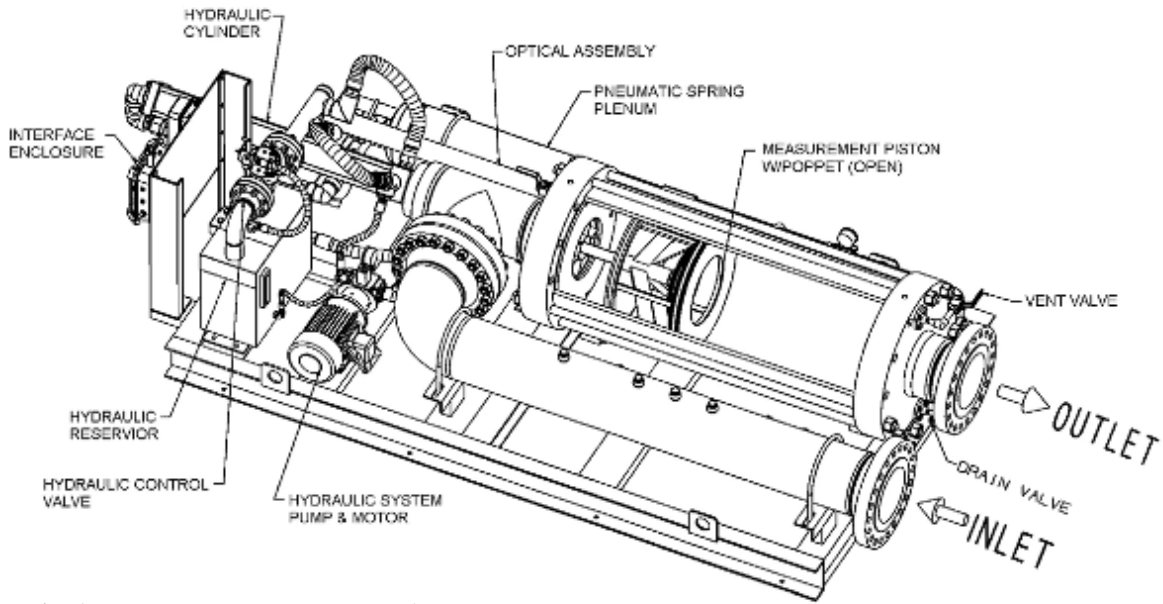

Typical 8", 12", 18", 24", 34" and 40"

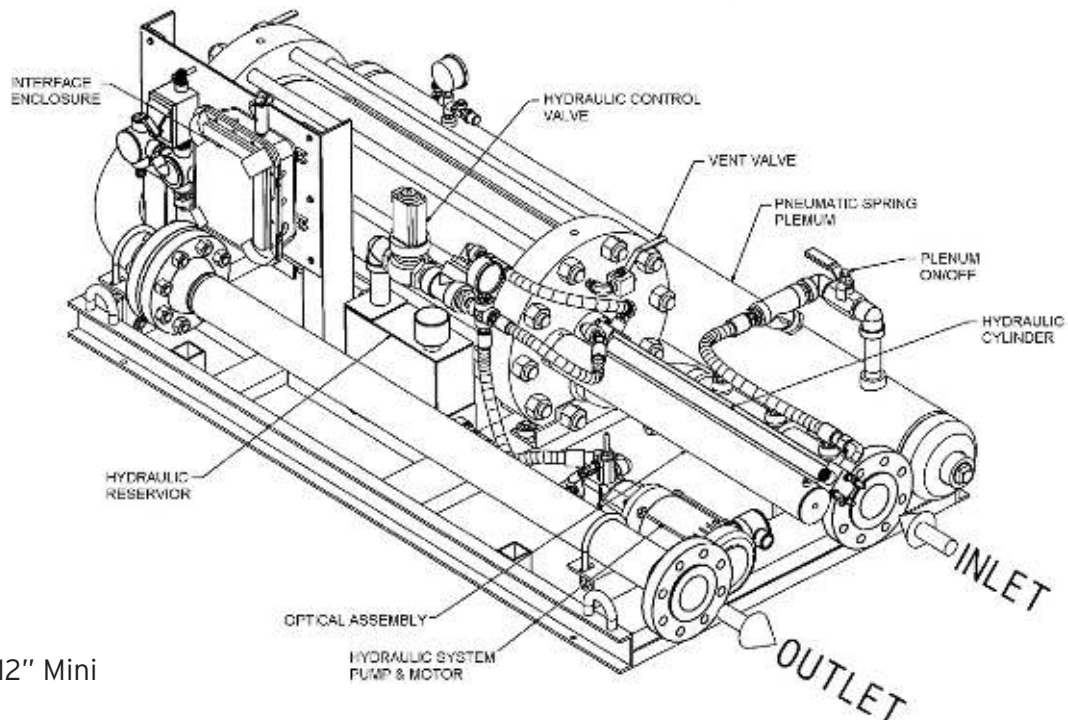

Typical 12" Mini

## 1.4 Technical Data

### NOTICE

Follow all the safety and equipment limits recommended in **1.4 Technical data** of this manual. It is the owner's and/or purchaser's responsibility to comply with these parameters.

### WARNING

#### PERSONAL PROTECTION HAZARD

Follow all parameters for the compact prover indicated below. Failure to do so may result in injury or equipment damage.

## Materials of Construction

Standard: 17-4 stainless steel flow tube with hard chrome plating, carbon steel pipe and flanges

## Standard maximum working pressure

8" to 24" Size: 150 lb. ANSI	285 psig (19.65 Bar) @ 100°F (38°C) 260 psig (17.93 Bar) @ 200°F (93°C)
8" to 24" Size: 300 lb. ANSI	740 psig (51.02 Bar) @ 100°F (38°C) 675 psig (46.54 Bar) @ 200°F (93°C)
8" to 24" Size: 600 lb. ANSI	480 psig (102.04 Bar) @ 100°F (38°C) 1350 psig (93.08 Bar) @ 200°F (93°C)
34" and 40" Size: 300 lb. ANSI	740 psig (51.02 Bar) @ 100°F (38°C) 675 psig (46.54 Bar) @ 120°F (49°C)

For intermediate pressures refer to ANSI B16.5  
Prover size based on flow tube diameter.

## Maximum working temperature

8" to 24" Size: -20 to 200°F (-29 to 93°C)  
34" and 40" Size: 20 to 120°F (-7 to 49°C)  
Standard ambient temperature range: -4°F to 104°F (-20°C to 40°C)  
Consult factory for other changes.

## IMPORTANT

Temperature span differential between tie rods and flow tube not to exceed 200 °F (93°C) on standard 8" to 24" models and 100 F° (38°C) on 34" and 40" models.

---

## Performance

Repeatability 0.02% or better (water draw)

## Standard capacities and specifications:

- Flow Range (1500:1): [See Table 1-2](#)
- Prover Nominal Base Volume (dependent on size): [See Table 1-2](#)
- Volume Ratio (Upstream/Downstream Volume): [See Table 1-2](#)
- Hydraulic System: Fill with type MIL-H-5606 (Aviation Grade E Hydraulic Fluid) or equivalent in quantities. [See Table 1-1](#)

Table 1-1 Hydraulic System Capacity

Prover Size	System Capacity
8"	3 gal (11.4 l)
12" Mini	3 gal (11.4 l)
12"	3 gal (11.4 l)
18"	10 gal (38 l)
24"	25 gal (95 l)
34"	60 gal (227 l)
40"	93 gal (352 l)

## NOTE:

Possible equivalents

- Mobile Aero HF series
- Aeroshell 41

Table 1-2 Standard compact prover set-up data

Nominal flow tube dia.	Provers rate ranges minimum maximum		Nominal prover base volume	Multiplier for upstream volume	Flowtube I.D	Wall thickness	Inlet/Outlet flange size	Nominal prover shipping dimensions (L X W X H)	Approx shipping weight
8"	0.167 GPM 0.632 LPM 0.239 BPH 0.0038 M3/HR	250 GPM 946 LPM 357 BPH 57 M3/H	5 gal (20 liters)	0.990590	8.250 (20.955 cm)	0.6875 (1.746 cm)	2"	121" x 56" x 50" (307cm x 142cm x 127cm)	2,200 lbs (998 kgs)
12" Mini	0.67GPM 2.54 LPM 0.96 BPH 0.15 M3/HR	1000 GPM 3780 LPM 1430 BPH 227 M3/H	10 gal (40 liters)	0.991670	12.250 (31.115 cm)	0.8750 (2.222 cm)	4"	147" x 62" x 55" (373cm x 157cm x 140cm)	4,400 lbs (1,995 kgs)
12"	1.17 GPM 4.43 LPM 1.67 BPH 0.27 M3/HR	1750 GPM 6623 LPM 2500 BPH 397 M3/H	15 gal (60 liters)	0.991670	12.250 (31.115 cm)	0.8750 (2.222 cm)	6"	172" x 67" x 57" (437cm x 170cm x 145cm)	4,900 lbs (2,223 kgs)
18"	2.30 GPM 8.71 LPM 3.29 BPH 0.52 M3/H	3500 GPM 13247 LPM 5000 BPH 794 M3/H	30 gal (120 liters)	0.993020	17.500 (44.450 cm)	1.2500 (3.175 cm)	8"	193" x 76" x 56" (490cm x 193cm x 142cm)	7,300 lbs (3,311 kgs)
24"	4.7 GPM 17.8 LPM 6.7 BPH 1.1 M3/H	7000 GPM 26495 LPM 10000 BPH 1595 M3/H	65 gal (250 liters)	0.993464 Pre 2006 0.992369	25.500 (64.770 cm)	1.0625 (2.699 cm)	12"	220" x 96" x 66" (559cm x 244cm x 168cm)	13,400 lbs (6,078 kgs)
34"	8.4 GPM 31.8 LPM 12.0 BPH 1.9 M3/H	12600 GPM 47691 LPM 18000 BPH 2860 M3/H	100 gal (400 liters)	0.988536	34.00 (86.360 cm)	1.2500 (3.175 cm)	16"	230" x 102" x 74" (584cm x 259cm x 188cm)	19,200 lbs (8,709 kgs)
40"	11.7 GPM 44.3 LPM 16.7 BPH 2.7 M3/H	17500 GPM 66237 LPM 25000 BPH 3972 M3/H	170 gal (650 liters)	0.985938	40.00 (101.60 cm)	1.500 (3.810cm)	20"	240" x 130" x 77" (610cm x 330cm x 196cm)	35,000 lbs (13,876 kgs)

**NOTE**

1. Temperature and pressure tap on the outlet flange (1" dia.) can be supplied upon request.
2. Fluid viscosity ranges up to 10,000 centistokes.
3. Considerations for meter type and pulse output quality should be made for all compact prover applications.
4. Compact prover performance depends upon the quality of the pulse signal from the meter being proved.
5. For more information on pulse quality and compact provers, reference API Chapter 4.2.
6. For certified dimensional drawings, please contact the factory.
7. Upstream multipliers are approximate. Actual values can be obtained from the Base Volume Certification (water draw) method.

Table 1-3 Power requirements

Size	AC line voltage, frequency and phase	Hydraulic system motor full load amps	Hydraulic system motor configuration	Hydraulic control valve in-rush amperage
8" and 12" Mini	115/60/1	13.4	1Hp Single	10
	220/50/1 & 230/60/1	6.7	1 Hp Single	5
	380/50/3	3.0	1.5 Hp Single	.2
	415/50/3	2.7	1.5 Hp Single	.2
	460/60/3	2.2	1.5 Hp Single	5
12"	115/60/1	19	1.5 Hp Single	10
	220/50/1 & 230/60/1	8.4		5
	380/50/3	3.0		.2
	415/50/3	2.7		.2
	460/60/3	2.2		5
18"	115/60/1	19	1.5 Hp Dual, 2 Circuits	.2
	220/50/1 & 230/60/1	19	1.5 Hp Dual, 1 Circuit	.2
	380/50/3	9.4	5 Hp Single	.2
	415/50/3	8.2	5 Hp Single	.2
	460/60/3	6.5	5 Hp Single	.2
	690/50/3	4.8	5 Hp Single	.2
24"	230/60/3	13	5 Hp Single	.2
	380/50/3	9.4		.2
	415/50/3	8.2		.2
	460/60/3	6.5		.2
	690/50/3	4.8		.2
34"	230/60/3	39	15 Hp Single	.2
	380/50/3	22		.2
	415/50/3	20		.2
	460/60/3	19.5		.2
	690/50/3	12.8		.2
40"	230/60/3	50	20 Hp Single	.2
	380/50/3	28		.2
	415/50/3	26		.2
	460/60/3	25		.2

**NOTE**

1. Consult the factory for optional voltages not listed.
2. The operating computer must be connected to a power source separate from that of the prover to avoid variance in signal caused by line load charge and discharge.
3. Grounding wire within power cable must be connected to the installed location electrical system grounding bus or electrical equivalent. A supplemental grounding cable is available as an option.
4. For provers that are not equipped with a main circuit breaker, sizing of the main circuit breaker should be based upon the hydraulic system motor full load amperage. Follow applicable electrical codes for proper requirements.

## Connection Requirements

Reference [Table 1-2](#) for flange sizes

Pneumatic spring plenum:

Dry compressed nitrogen is required for charging the spring plenum.

### **Pressure drop: (Inlet flange to outlet flange)**

Approximately 11.2 psig on gasoline at maximum flow (Metric units - .79 Bar) Piston only:

Approximately 3 inches (7.6 cm) of water during a proving pass.

**Approvals:** All electrical components contained meet global requirements, including CSA-US, ATEX and IECEx and IECEx electrical certification.

## Section 2: Installation and Set-Up

### 2.1 Installation

The compact prover may be installed permanently in a process line or used as a portable unit. The prover is intended for above ground use and should be operated level to prevent the formation of air pockets within the flow tube. A permanently installed standard prover should be set up horizontally with considerations given to the accessibility of electrical power and control operation. Consult a Brodie representative for further information regarding portable provers.

---

#### **IMPORTANT**

**For optional vertical installation, special modifications to the prover hydraulic system and flow tube supports will be required. The standard prover built for horizontal installation should not be installed in a vertical position without proper modifications.**

---

Refer to [Figure 2-1](#) for a typical, permanent, compact prover installation in a process line. Installation of a double block and bleed valve configuration is recommended in the process line to assure that all metered fluid is passing through the prover. Be sure to follow API guidelines for ANSI flanged connections and proper locating distance from the meter under test. Use gaskets and retaining bolts of proper size and pressure rating for prover inlet and outlet flanges. Reference [Table 1-2](#) for correct flange information. Consideration of available workspace around the prover is necessary for normal operation and maintenance.

When installing this equipment, bolting must conform to the requirements of ASME B16.5 paragraph 5.3 and to the material requirements of ASME B16.5 [Table 1B](#). Gaskets must conform to the requirements of ASME B16.20.

It is the customer's responsibility to ensure that piping or other attachments connected to the compact prover do not place adverse stresses on the compact prover. The design of the compact prover has not been assessed for the effects of traffic, wind or earthquake loading.

It is the customer's responsibility to provide fire prevention measures and equipment per local regulations.

The compact prover has been designed with a minimum of 1.5mm (1/16 inch) corrosion allowance. The customer should implement a periodic inspection and maintenance program to ensure that no part of the compact prover's pressure-retaining components has corrosion or erosion exceeding this amount.

**IMPORTANT**

It is the customer's responsibility to install this equipment in a system that provides adequate over-pressure protection.

---

 **WARNING****EXPLOSION HAZARD**

Do not exceed the maximum working pressure of prover as stamped on the nameplates. Failure to observe pressure rating limits may result in serious personal injury and equipment damage.

---

**IMPORTANT**

Lines should be flushed thoroughly to rid piping of potentially damaging foreign material such as welding bead, pipe scale, etc. before the prover is placed into service. A strainer of proper size should be installed upstream of the prover to protect it from the introduction of foreign material.

Figure 2-1 Typical prover installation

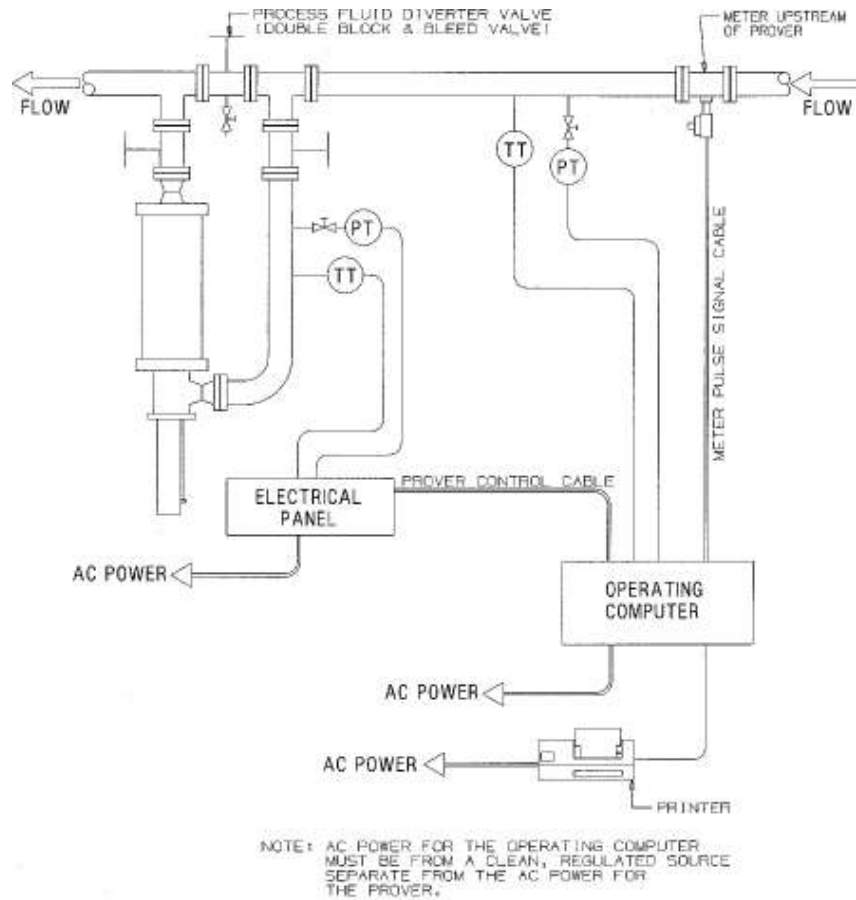

## 2.2 Set-Up

### 2.2.1 Supplying Electrical Power to the Compact Prover

Reference [Table 1-3](#) for standard voltage and amperage information. Optional voltage and amperage information not listed in [Table 1-3](#) is provided with the documentation package (electrical schematic) shipped with every prover. If this information is not included with the shipment, contact a local Brodie representative for assistance.

Standard provers are shipped with a multi-conductor power cable for connection to a power supply. If an electrical conduit connection is desired, remove the existing power cable. Access to the motor starting switch will be necessary for this conversion. Be sure to follow all applicable electrical codes for the area of installation.

## 2.2.2 Connection of the Operating Computer

Standard provers are shipped with a control cable for connection to the operating computer. If an electrical conduit connection is desired, remove the existing control cable. Access to the interface enclosure will be necessary for this conversion. Be sure to follow all applicable electrical codes for the area of installation.

The compact prover control signals are designed to worldwide control standards. This includes digital and analog signals. The electrical schematic will define how each connection (conductor) is used. Manuals and instructions supplied with the operational computer of choice will assist with proper control connections. Reference [Section 5.2](#) for additional troubleshooting information. If you require further assistance for these connections, contact a local Brodie representative.

The operating computer will need to be properly configured for the application and must be capable of Dual Chronometry Pulse Interpolation. This calculation method requires the computer to have a high frequency master oscillator, which counts time in 0.000001 parts of a second.

This master oscillator must operate two counters, referred to here as "Time A" and "Time B". Time "A" must start counting when the flag trips the first detector switch. Time "B" must start counting with the leading edge of the first flowmeter pulse after Time A has started.

Time "A" is stopped when the flag trips the final detector switch. Time "B" is stopped with the leading edge of the first flowmeter pulse after Time "A" has stopped, (Reference [Figure. 2-2](#)). Using the ratio of Counter Time "A" and Counter Time "B" will allow for accurately counting a fraction of a flowmeter pulse to within 1 part in 10,000 as shown below:

$$K = \frac{\text{Time 'A'}}{\text{Time 'B'}} \times \frac{C}{D}$$

K = K-Factor, or pulses per unit volume, from the flowmeter

A = Time for displaced volume

B = Time for whole meter pulses

C = Total number of whole meter pulses

D = Displaced volume

Qualified personnel who are knowledgeable of the computer's operating system, configuration variables, and compact proving applications should complete the configuration of the operating computer.

Figure 2-2 Double Chronometry

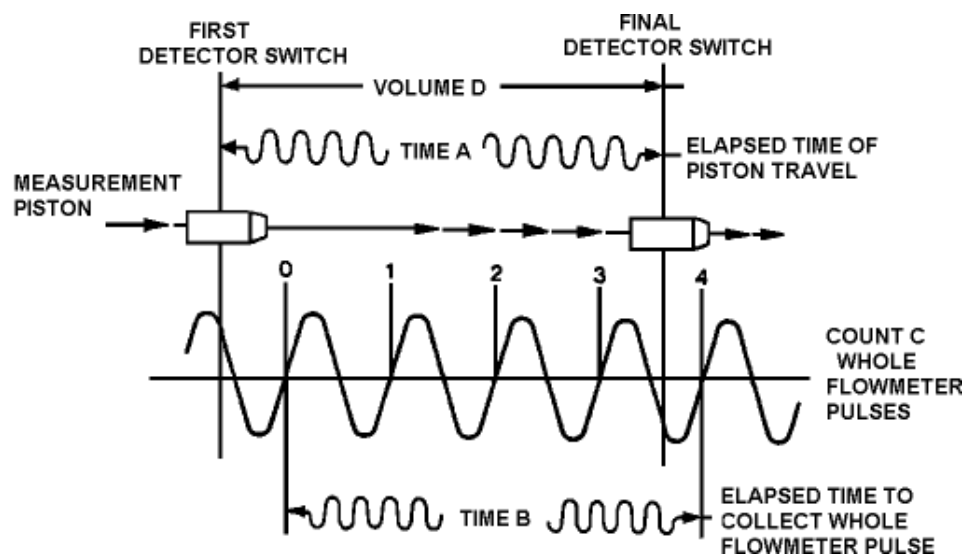

### 2.2.3 12 or 24V DC Interface Board

There are two (2) different styles of interface boards: 12V DC and 12/24V DC. See Figure 2-3 and 2-4. The power required for the interface board is supplied through the control cable. The DC power source is typically located in the control room or can be supplied from the operating computer if so equipped. See the electrical schematic provided with the prover documentation package for proper connections of the control cable.

The 12V interface board is designed to operate on 12V DC ( $\pm 15\%$ , 100mA max). The 12/24V interface board can operate on either 12 ( $\pm 15\%$ , 100mA max) or 24V DC ( $\pm 15\%$ , 250mA min) depending on the configuration of jumper J6, see Figure 2-4. For 12V operating power, J6 must be jumpered to pins 1 and 2. For 24V operation, J6 must be jumpered to pins 1 and 3. If operating voltage is applied incorrectly, there is an integral fuse for board protection. In the event that the fuse is blown, confirm the configuration of jumper J6 and replace the fuse with a 100mA, fast blow fuse ONLY.

The 12/24V interface board is installed in all compact provers made after September 2002. It may also be used to replace the 12V interface board on older model provers. Contact a Brodie representative if you are unsure which interface board your compact prover is equipped with or if you need assistance replacing the old 12V board with the new 12/24V board. Request service bulletin SE101 for detailed retrofit information.

#### **IMPORTANT**

**Do not handle electronic-sensitive equipment without an ESD grounding wrist-strap. Failure to use an anti-static grounding device could cause damage to the compact prover electronics and render them inoperable.**

Figure 2-3 12/24V Prover interface board [old style]

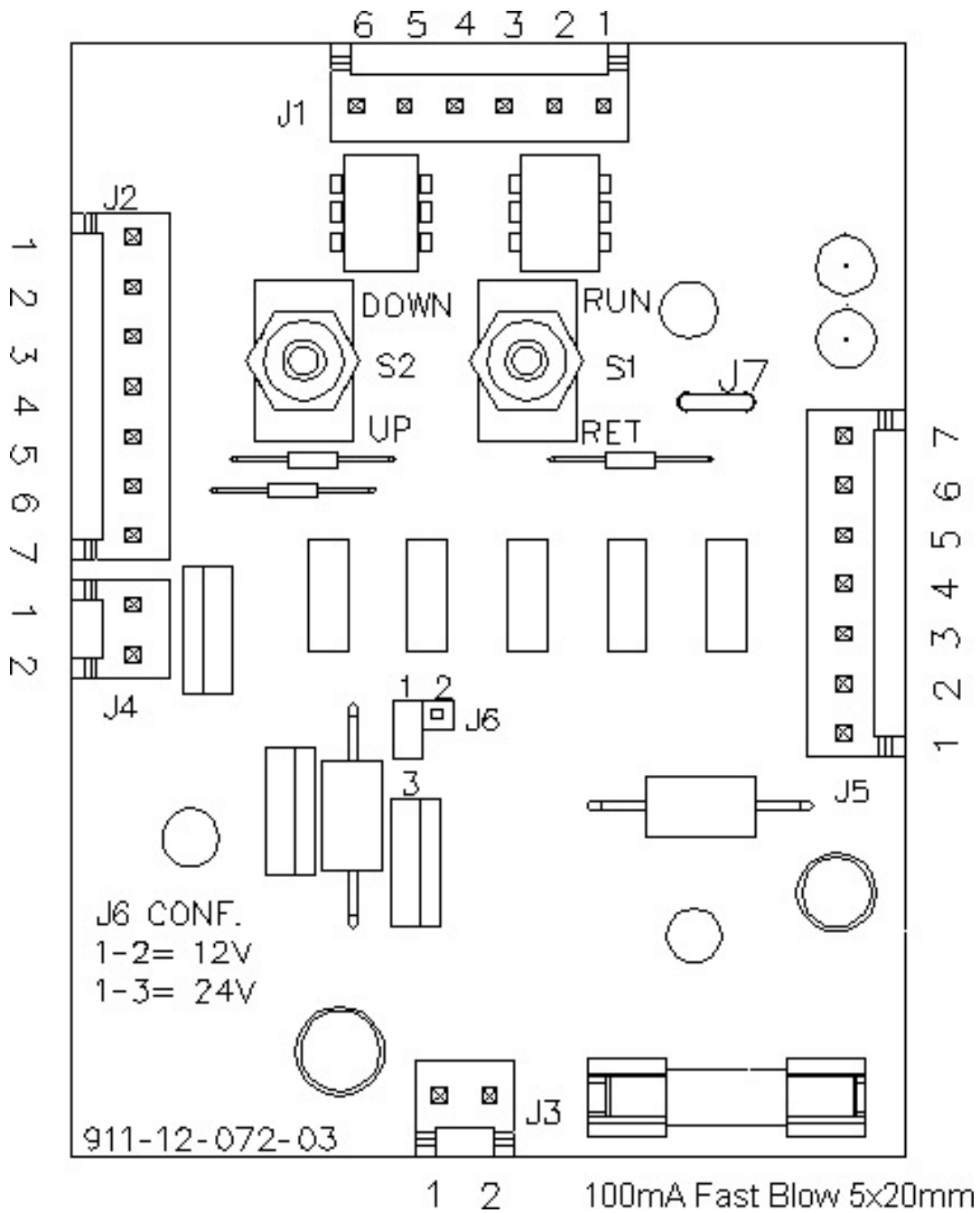

- J1: TO OPTICAL ASSEMBLY (PIN 6 NOT USED)
- J2: TO CONTROL CONNECTION
- J3: TO WATER DRAW HARDWARE KIT
- J4: TO RUN VALVE
- J5: FOR EXTERNAL CONTROL OF S1 AND S2
- J6: 1-2 12V OPERATION  
1-3 24V OPERATION
- S1: RUN - RETURN
- S2: UPSTREAM - DOWNSTREAM

Figure 2-4 12/24V Prover interface board [new style]

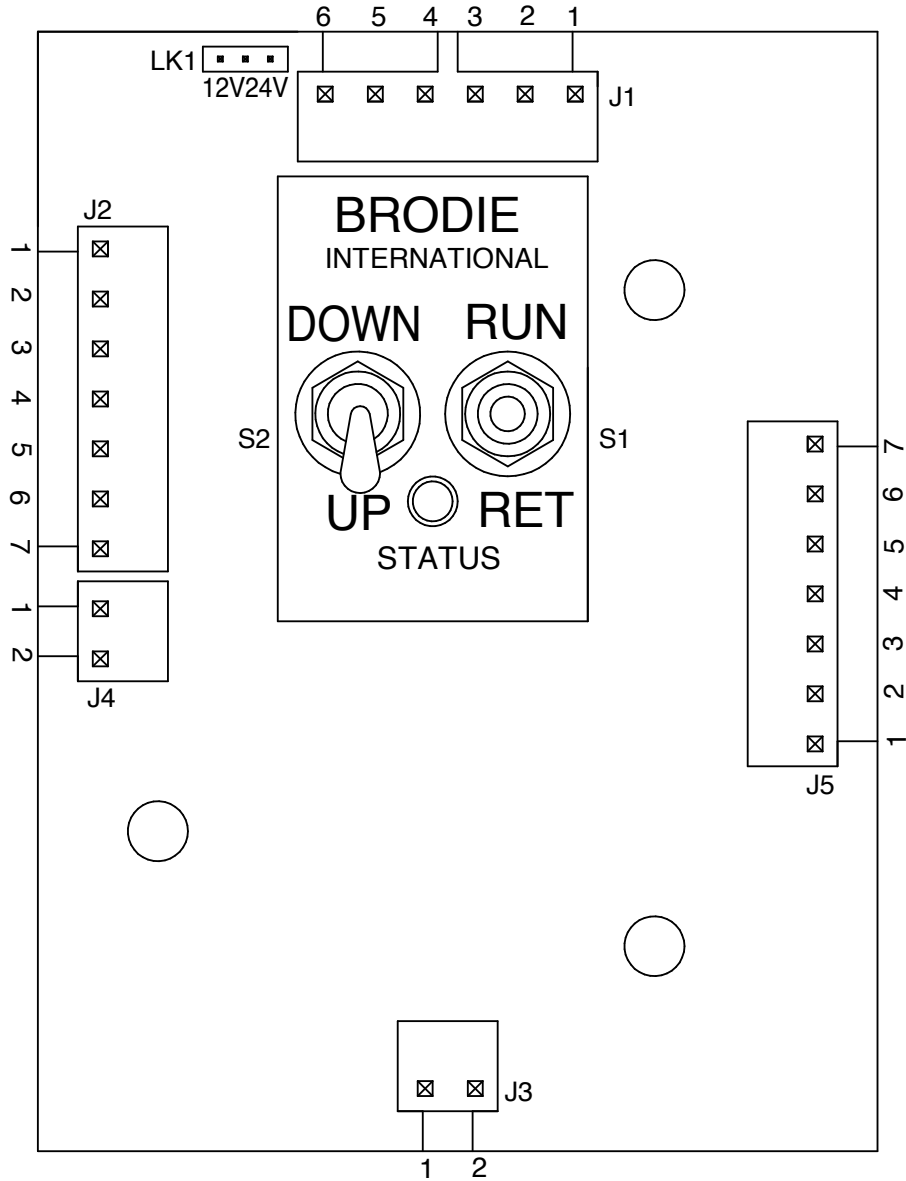

- J1: TO OPTICAL ASSEMBLY (PIN 6 NOT USED)
- J2: TO CONTROL CONNECTION
- J3: TO WATERDRAW HARDWARE KIT
- J4: TO RUN VALVE
- J5: FOR EXTERNAL CONTROL OF S1 AND S2
- S1: RUN - RETURN
- S2: UPSTREAM - DOWNSTREAM

## 2.2.4 Charging the Pneumatic Spring Plenum

The pneumatic spring plenum must be charged for proper operation. The prover is shipped from the factory with an empty spring plenum for safety. Nitrogen is NOT supplied with the compact prover and must be acquired locally before meter proving can begin. Calculations for proper pressure settings of the spring plenum are discussed in [Section 3.2](#).

As an option, the compact prover may be equipped with an automatic plenum adjustment panel. The panel consists of charge and vent solenoid valves and a pressure transmitter. A typical panel is shown in [Figure 2-5](#), a connection diagram is shown in [Figure 2-6](#). An operating computer with the adjustment routine pre-programmed, using an analog input (4-20mA) and two digital outputs, will be able to automatically adjust the spring plenum pressure before proving runs begin. See [Section 5.4](#) for troubleshooting these signals.

Figure 2-5 Typical nitrogen adjust panel

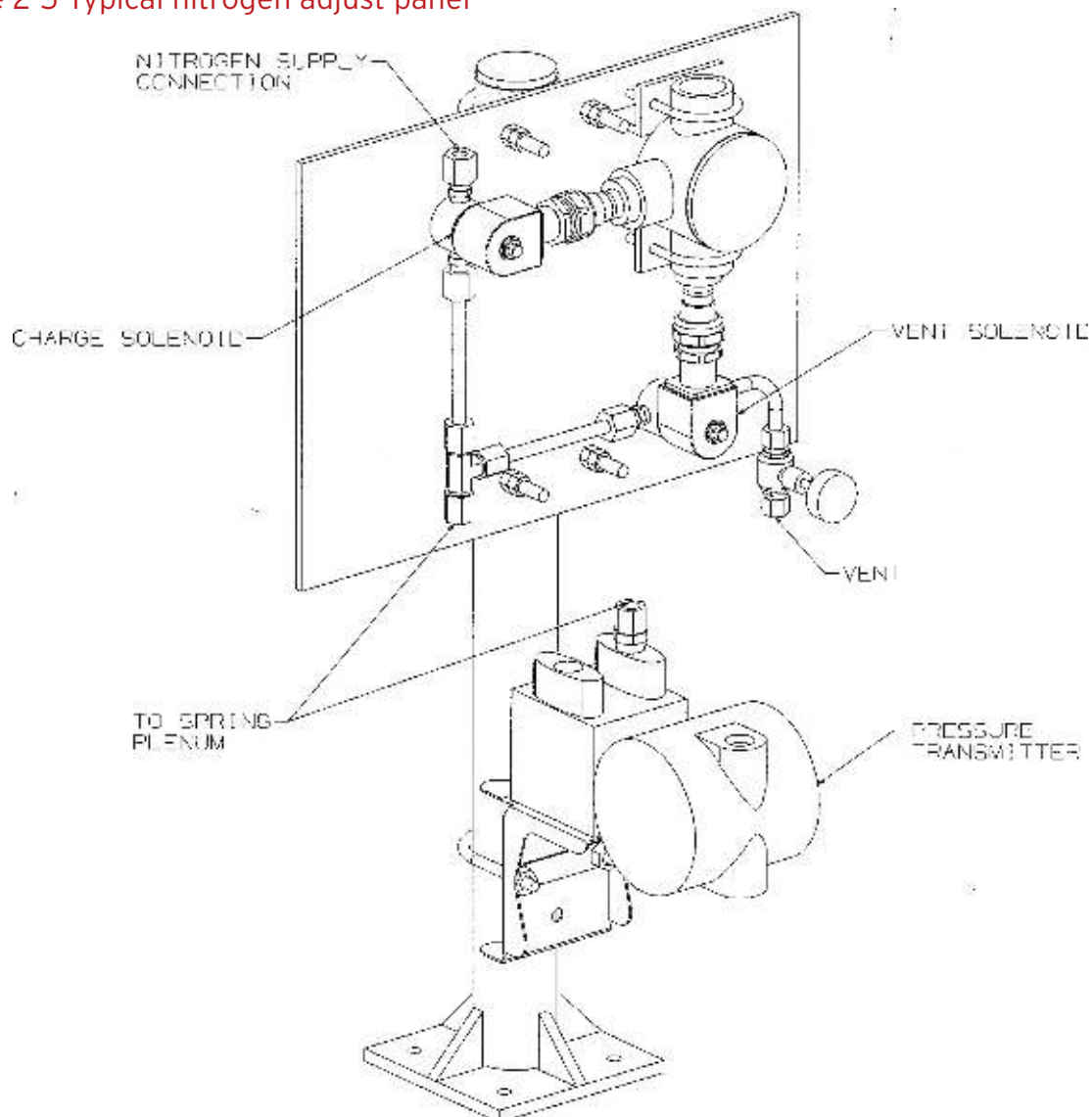
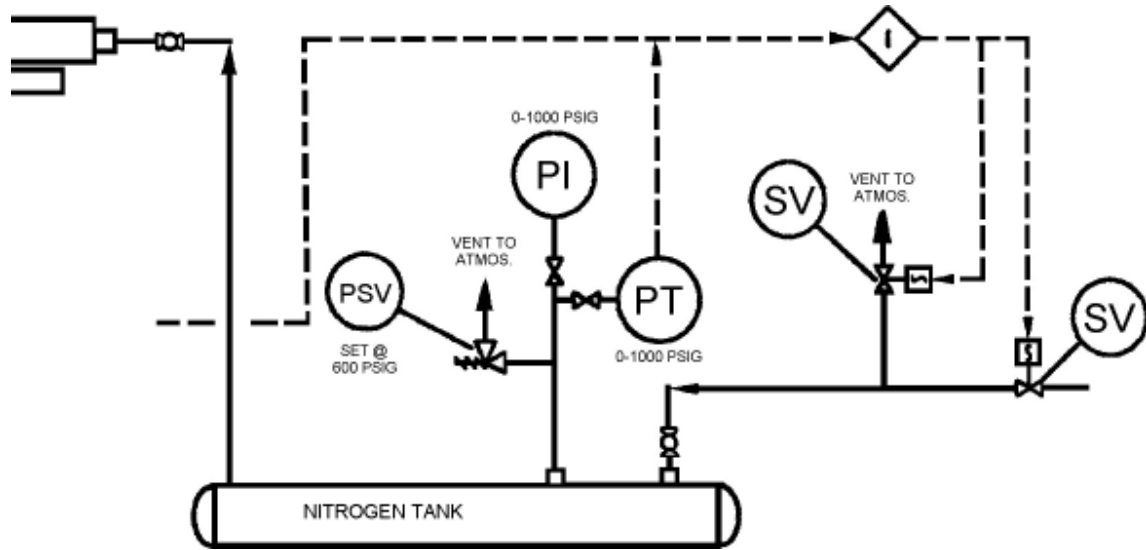

Figure 2-6 Connection diagram



### 2.3 Base Volume Certification

The prover base volume has been certified at the factory using the volumetric displacement method (water draw) per API guidelines. The base volume has been adjusted to 0.0 gauge pressure and the reference temperature as stated on the volumetric determination report supplied with each prover documentation package. The operating computer will need to be programmed with these base volumes. Upstream or downstream volumes will be used depending on the application and location of the meter under test.

The volumetric displacement (water draw) technique, described in [Section 4.2](#), is the factory recommended procedure for certification of the base volume of the compact prover. It is recommended that this procedure be repeated at regular intervals to confirm proper operation. Frequency of base volume determination is dependent on usage, but should not exceed 3 years. Certification may be necessary following repair or service procedures involving any disassembly or seal replacement of the piston, poppet or flow tube. Certification is not necessary following repair of the hydraulic cylinder if the flow tube is not disassembled. For specific information regarding prover base volume certification related to maintenance of the optical assembly, see [Section 4.6](#). A seal wire should be installed to assure calibration integrity once certification is completed as described in [Section 2.5](#).

The upstream volume of any compact prover is slightly smaller than the downstream volume due to the main piston shaft and optical shaft which are both located on the upstream side of the piston. If the meter is located upstream, or on the inlet side of the prover, then the upstream volume must be used.

If the meter is located downstream, or on the outlet side of the prover, then the downstream volume must be used.

## 2.4 Calibration integrity seal installation procedure

### Purpose:

The purpose is to provide a procedure for ensuring the calibrated volume integrity of the compact prover. The optical assembly as shown in figure 1A has a simple but sure way of ensuring the integrity of the assembly.

A security seal can be applied to prevent removal of the cover of the optical assembly which contains the solid state volume detectors.

The purpose of this seal is to prevent removal of this cover which would expose the switches to possible tampering which could affect the calibrated volume of the compact prover.



FIGURE 1A

Location of optical assembly with seal nut and seal.

## Section 3: Operation

### 3.1 General operational theory

The operational sequence of the compact prover is as follows:

1. The measurement piston is normally in the upstream (standby) position, with the poppet valve open, and is held in place by the hydraulic pressure on the actuator piston (Figure 3-1).
2. The hydraulic control valve opens and releases the hydraulic pressure. Pressure from the pneumatic spring plenum, on the upstream side of the actuator piston, closes the poppet valve and the piston begins moving downstream at the process fluid flow rate (Figure 3-2).
3. As the measurement piston moves downstream, the optical volume switches are 'tripped' by the flag connected to the piston (Figure 3-3). These volume switch signals are instantly sent to the operating computer for calculations discussed in Section 4.6.
4. When the flag trips the second optical volume switch, the hydraulic control valve closes. Hydraulic pressure builds and begins to push the actuator piston upstream, opening the poppet valve. Process fluid is then allowed to flow through the piston (Figure 3-4).
5. The actuator piston, measurement piston, poppet, actuator shaft, detector shaft and flag will then move back to the upstream (standby) position (Figure 3-5). Once the upstream position is reached (Figure 3-1), the hydraulic pump will assume it's neutral condition maintaining hydraulic pressure to hold the measurement piston upstream. The prover is now ready to begin another pass.

#### NOTICE

A positive stop feature is incorporated into the outlet flange for fail safe operation. This prevents any accidental blockage of the process flow stream. Reference Figure 3-4.

Figure 3-1 Standby position

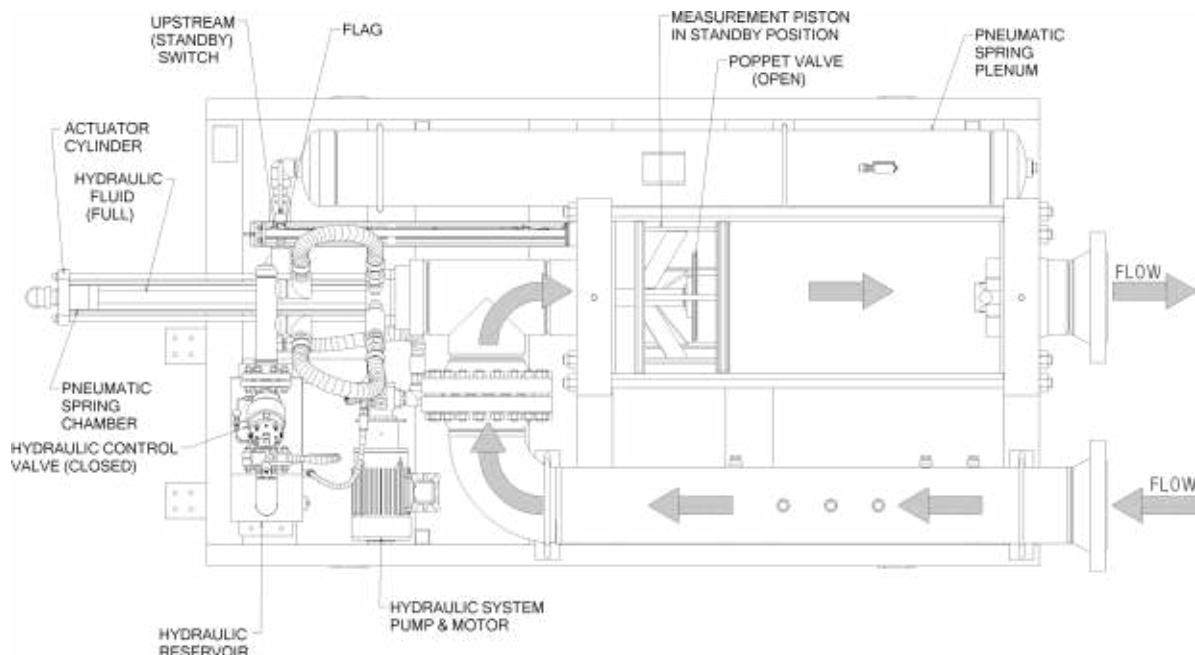

Figure 3-2 Initial motion

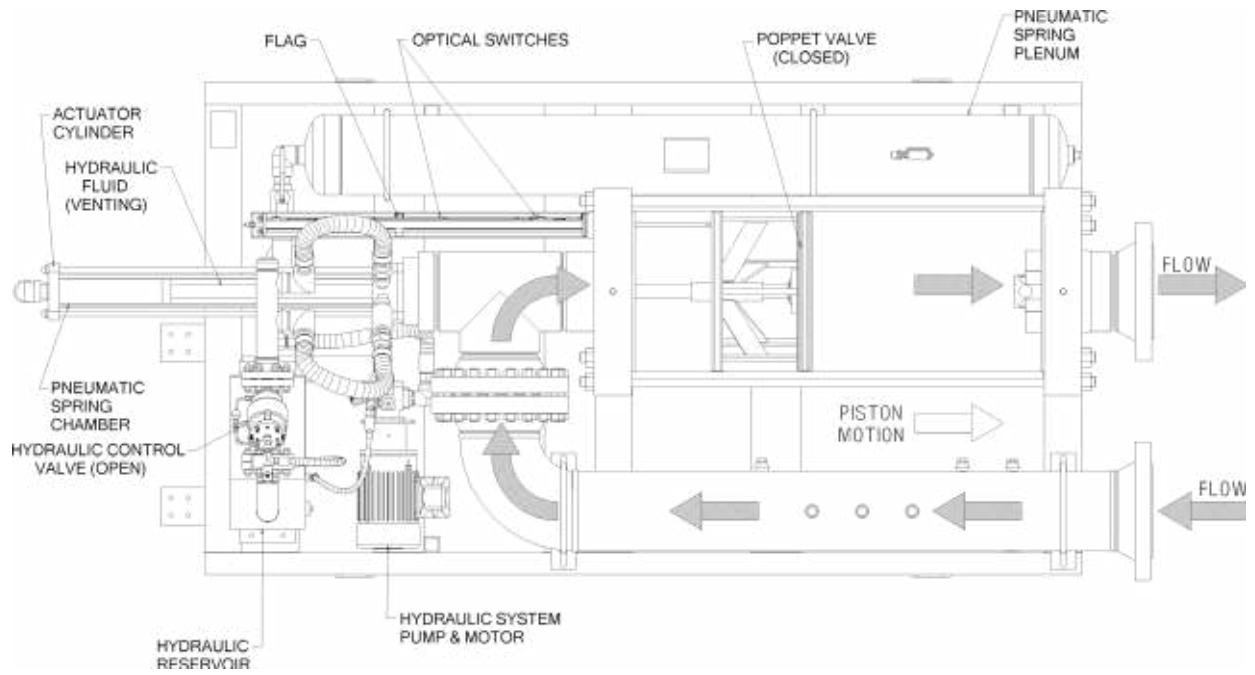

Figure 3-3 Proving

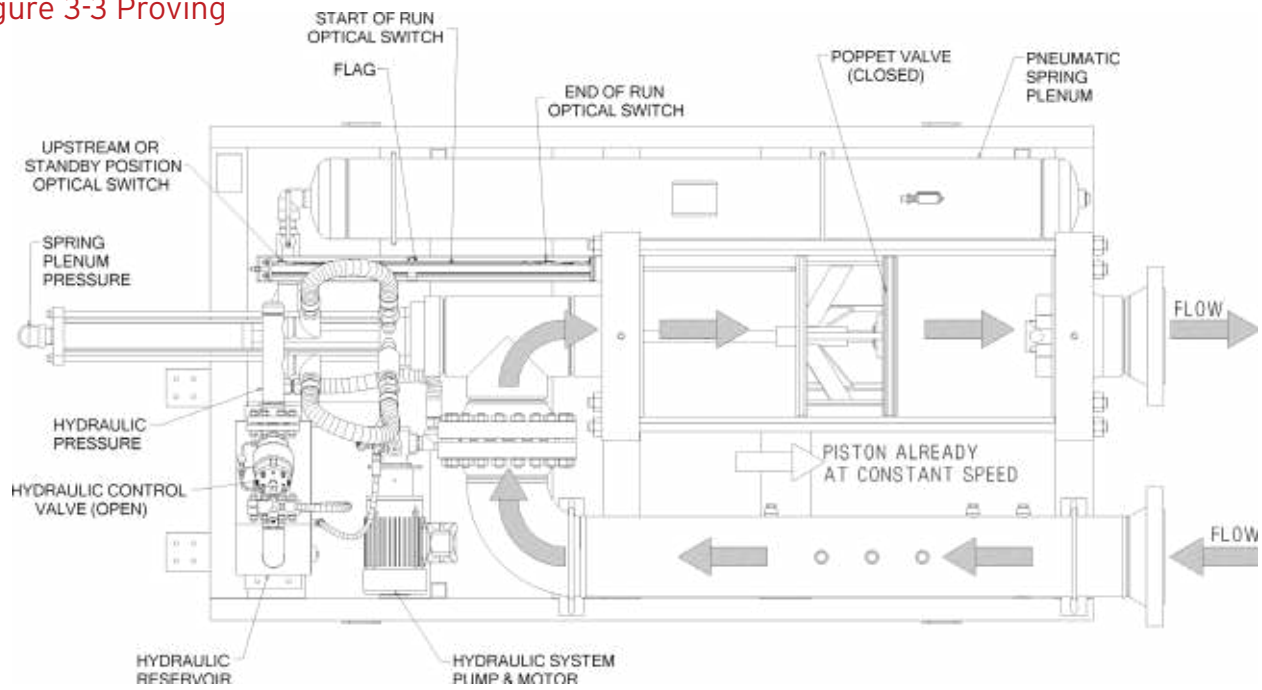

Figure 3-4 End of proving run

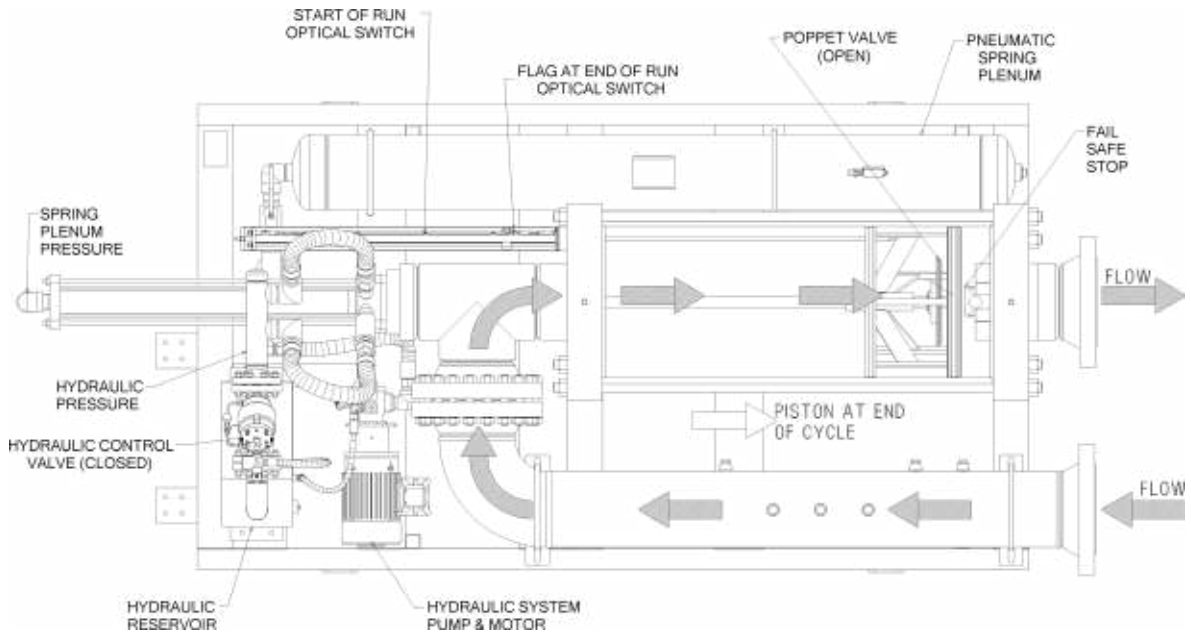
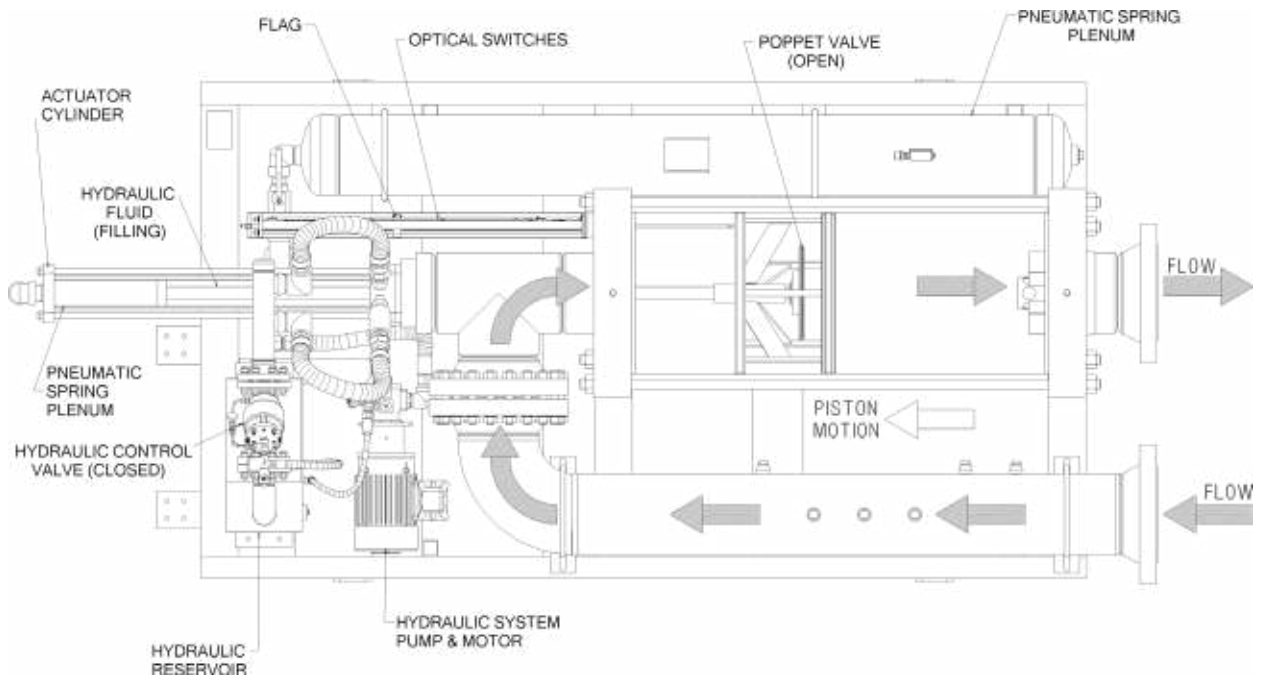

Figure 3-5 Piston returning to upstream position



### 3.2 Operating Instructions

The compact prover should be connected to the process line, similar to Figure 2-1, either upstream or downstream of the meter under test. Electrical power should be supplied and the operating computer should be connected to the prover. The operating computer should also be configured for the application. If these conditions are not met, DO NOT attempt to operate the compact prover. Refer to Section 2 for Installation and Set-up procedures.

1. Check all drain and vent valves to be sure that they are closed. Vents and drains are located on the top and bottom of the flow tube end flanges. Reference Figure 1-2.
2. Open the spring plenum shut-off valve.
3. The pneumatic spring plenum must be charged with dry nitrogen for proper operation. Check the pressure in the spring plenum. There will be a factory-installed gage mounted to the plenum tank for reference (Figure 3-6). The proper plenum pressure is determined by the following formula:

$$\text{Plenum Pressure} = \frac{\text{Pipeline Gauge (psig)}}{R} + 60\text{psig}$$

where R is a known constant for each size prover. See Table 3-1.

Table 3-1 Spring plenum 'R' values

Prover Size	R
8"	3.5
12" Mini	3.2
12"	3.2
18"	5
24"	5*
34"	3.7
40"	4.45

\* R = 5.88 for Provers shipped before January 1, 2006

Figure 3-6 Spring plenum

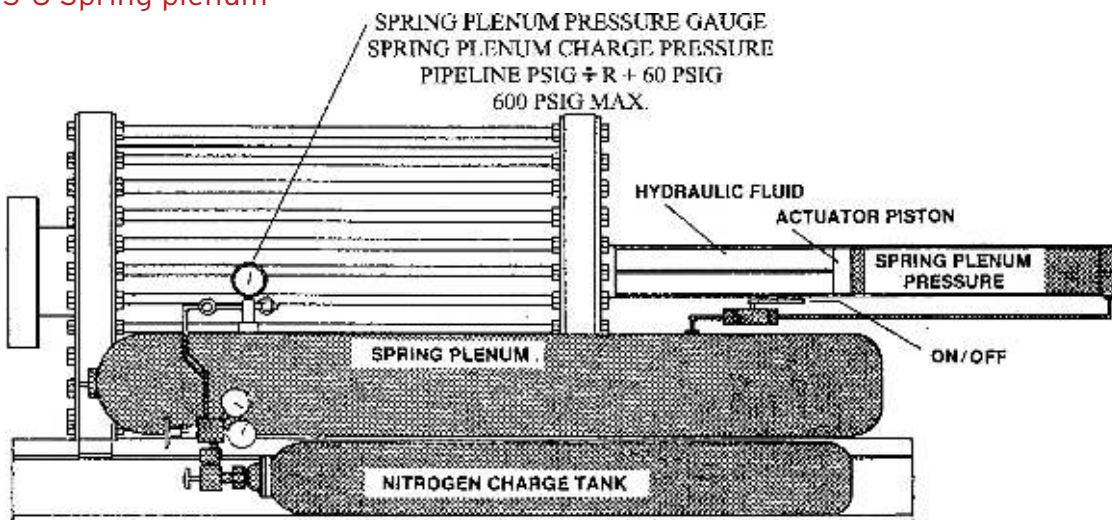

**⚠ CAUTION**

**EXPLOSION HAZARD**

Regulate the pressure of the supply source to the allowable level and avoid exceeding the maximum working pressure of the tank. Failure to do so during the filling of the Nitrogen Tank could result in serious personal injury.

**NOTICE**

If the plenum pressure is greater than the calculated value, the excess pressure must be vented from the plenum. If the plenum pressure is less than the calculated value, the supply bottle will need to furnish the necessary pressure needed. Connect the supply bottle according to manufacturer's instructions and charge the spring plenum to the required pressure.

**NOTE**

1. If prover installation is vertical, use 40 psig in the above formula in place of 60 psig.
2. For provers equipped with the automatic plenum adjustment panel, plenum pressure should be automatically adjusted before the proving cycle begins. The operating computer should be configured for this application. See Section 2.2.4 and Section 5.4 for troubleshooting. For vertical provers with plenum adjust panel, consult factory for new "R" value.
3. With the hydraulic system motor not running, check to see that the hydraulic reservoir is filled to approximately 75% capacity. If not, fill tank to proper level using hydraulic fluid specified in Section 1.4.
4. Turn on the hydraulic pump. The hydraulic pressure should build to 380-400 psig (27- 28 kg/cm) once the piston reaches the upstream (stand-by) position. This is verified by the hydraulic system pressure gage, typically located on the hydraulic pump (Figure 3- 7).
5. Slowly open the inlet valve to allow the process fluid to flow into the prover.
6. Vent all air from the system using the hand valves located on the inlet and outlet flanges of the flow tube. Slowly close the process fluid diverter valve (double block and bleed) and open the outlet valve. The prover is now ready to begin the proving cycle.

Figure 3-7 Hydraulic system

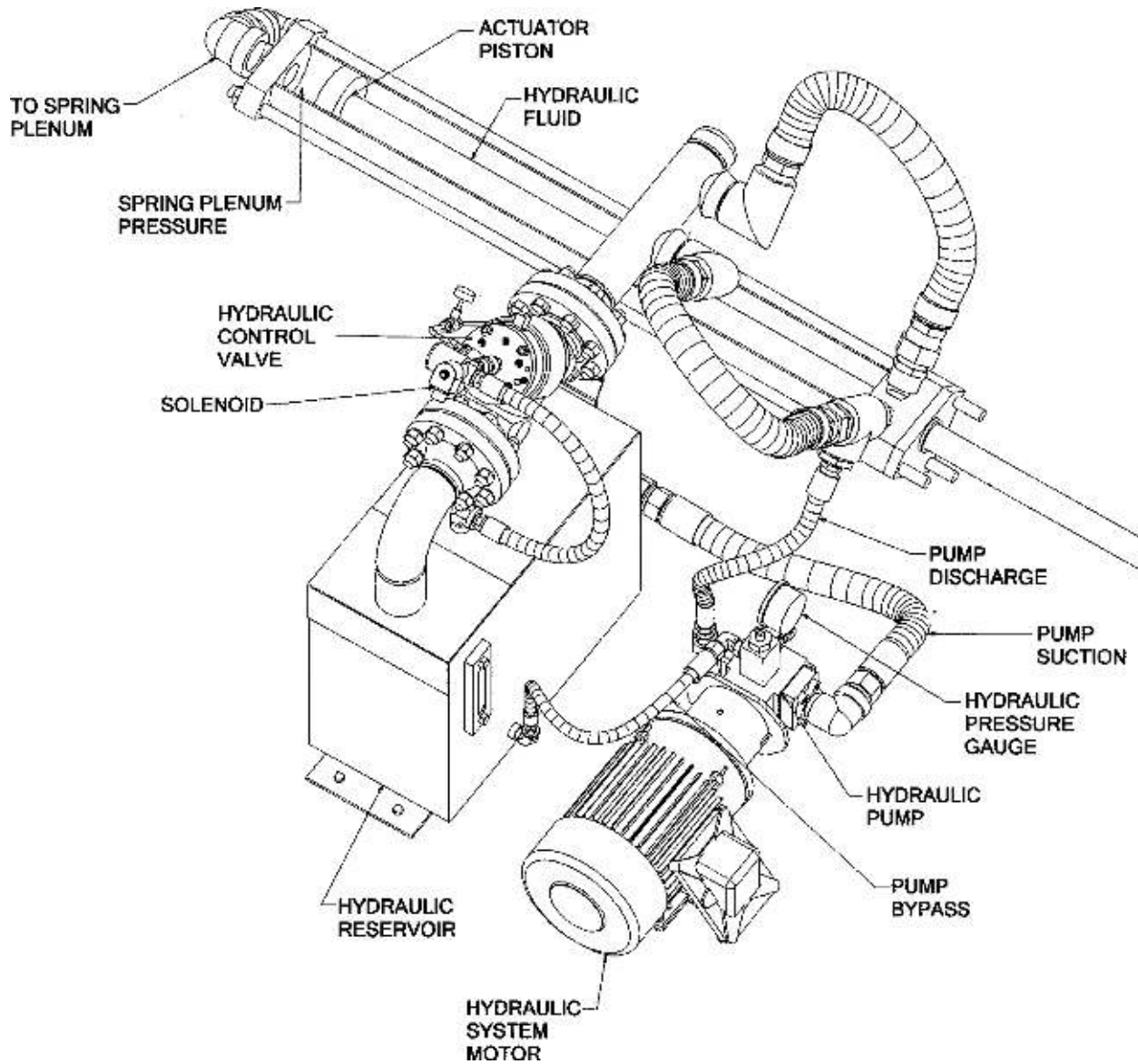

7. Connect the signal cable from the meter under test to the operating computer for proving operations. Once the operating computer receives all the signals, proving runs can begin. Reference the operating computer instruction manual for proper computer operation.
8. After proving runs are completed and results are satisfactory, the process flow may be diverted back to the process line as described in steps 10 and 11. Once this is done, power down the prover.
9. Open the process fluid diverter valve (double block and bleed) and slowly close the inlet/outlet valves to the process line.

If the process flow is to be left running through the prover, be sure to leave the hydraulic system motor running. The hydraulic pump will go into by-pass mode and hold the piston upstream. The motor will draw minimal current for low power consumption.

10. Drain the prover flow tube by opening the appropriate drain and vent valves located on the top and bottom of the inlet and outlet flanges.

**IMPORTANT**

Disposal of drained fluid should be done in an environmentally responsible manner.

## Section 4: Maintenance

### **CAUTION**

#### **MAINTENANCE HAZARD**

Ensure that all equipment doors are closed and protective covers are in place, except when maintenance is being performed by qualified persons.

Failure to do so can cause personal injury.

### 4.1 Seal Leak Check

For factory part number of seal Leak Detector Kit, see [Section 7: Parts list](#), Parts. Reference [Figure 4-1](#) and [Figure 4-2](#).

Figure 4-1 Leak detector kit



## IMPORTANT

It is **ESSENTIAL** that the liquid and prover temperatures remain stable during the leak check procedure as thermal expansion or contraction will give incorrect results.

The kit shown in Figure 4-1 is designed to operate with the Optical Assembly cover tube securely anchored in place. The mounting boss on the outboard end of the cover tube must be approximately 90° from the support bracket. Re-position if necessary.

The Compact Prover measurement piston seals may be checked as follows:

1. Block the prover **OUTLET** using a double block and bleed valve (bubble-tight shut off) or blind flanges. Check the block and eliminate any leaks.
2. Fill the prover with fluid and bleed **ALL AIR** from the flow tube by operating the vent valves located on the inlet and outlet flanges. This operation may move the measurement piston within the flow tube. Verify that all the vent and drain valves on the prover are free from leaks. Eliminate any and all leaks if necessary.
3. Verify the spring plenum pressure for the fluid pressure applied. See Section 3.2, step 3, for proper calculations. Adjust the spring plenum pressure to the correct calculated value. A minimum of 75 psig (5.3 kg/cm) is required.
4. Remove the screw from the boss on the end of the optical cover. Thread the indicator stand into the boss. Mount the dial indicator onto the indicator stand. Remove the screw from the end of the optical support stud.

Figure 4-2 Leak detector kit installed

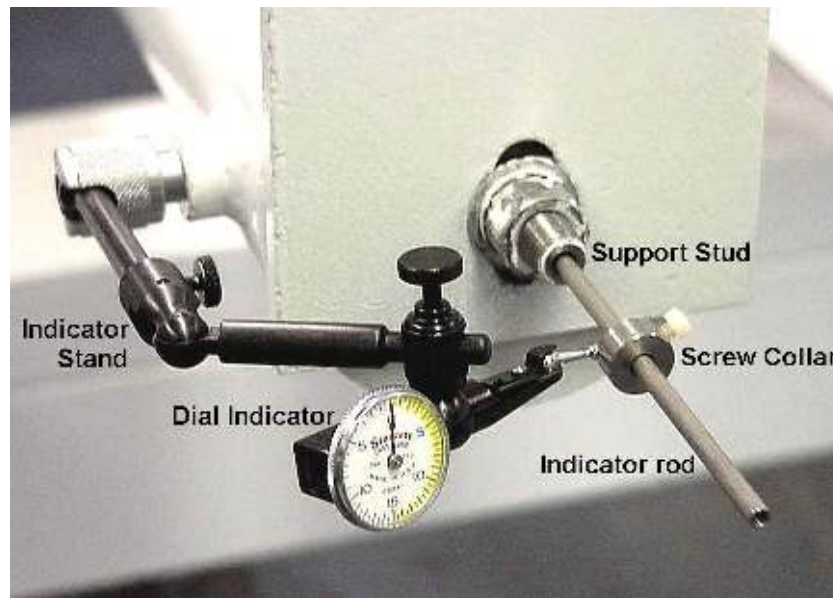

5. Place the measurement piston in the upstream position for simple attachment of the indicator rod. The measurement piston may be moved upstream by activating the hydraulic system.
6. The indicator rod is designed in multiple sections to span a distance that will reach the length of the optical assembly. This allows for multiple leak check positions along the flow tube. The first rod piece to be used is the piece with the larger thread. Insert this piece through the hole in the support stud and thread into the end of the detector shaft. Add rod sections as necessary to reach leak check positions desired, pay attention to the area between the volume switches. The measurement piston can be moved downstream by releasing pressure on the outlet flange vent valve.

### **IMPORTANT**

**Do not allow indicator rod to completely go into the support stud while moving the measurement piston downstream. Allowing the indicator rod to go completely into the support stud may result in severe damage to the equipment**

7. Be certain the hydraulic system motor is not running before the leak check test begins. This assures that only the spring plenum pressure is acting on the measurement piston.
8. Position the dial indicator probe near the indicator rod. Slide the screw collar down the indicator rod until contact is made with the probe of the dial indicator. Move the screw collar only slightly more in order to 'pre-load' the dial indicator and then tighten the collar to the indicator rod.
9. Zero the dial indicator and monitor for five minutes. A dial indicator movement greater than 0.004 inches (.102 mm) in five minutes indicates that a leak is present in the system. Inspect the system and eliminate any leaks. Remove any possible trapped air. Refer to Section 5: Troubleshooting for detailed instructions on measurement piston seal replacement if necessary.
10. Once testing is complete and results are satisfactory, return the measurement piston to the full upstream position and remove all parts of the indicator rod and the remaining components of the seal leak detector kit from the prover and replace the screws in the support stud and mounting boss.

## **4.2 Base Volume Determination**

### **4.2.1 Certification techniques**

Compact prover base volume determination varies with frequency of use and operating environment. Annual base volume re-certification is typical. Re-certification cycles should not exceed three (3) years. The volume determination procedures in this manual are designed to assist the user in creating an effective certification program.

The exact upstream and downstream base volumes must be known for correct proving calculations. For example, a 12" compact prover with a nominal volume of 15 U.S. gallons could be determined to have an exact volume of 15.00123 or 14.99712 gallons. These types of numbers are typical and necessary. The particular volume used is determined by the physical location of the meter under test, either upstream or downstream of the prover. If only one base volume is used for proving, base volume certification will only need to be completed for the needed volume and not for both.

The base volume of the compact prover is verified at the factory using test measures that are traceable to the National Institute of Standards and Technologies (NIST). Additional information about certification techniques can be found in the American Petroleum Institute (API) manual of Petroleum Measurement Standards, Chapter 4.2 for Small Volume Provers, Chapter 4.7 for Field Test Measures, and Chapter 12.2 for Calculation of Petroleum Quantities.

### Volume Displacement Certification:

The following procedures describe the compact prover base volume determination using the water draw method. There are three procedures explained; (a) an Upstream only, (b) a Downstream only, and (c) the Combined method. The measurement piston seal integrity should be verified prior to any water draw by performing the seal leak check as described in [Section 4.1](#).

### IMPORTANT

Before certification is attempted, the prover should be level and isolated from any connecting piping systems other than those related to the water draw. In choosing the location of the prover during the test, temperature variations must be considered. Temperatures must be maintained as stable as possible throughout the operation.

### Equipment Required:

- Water draw hardware kit with manual valves and a solenoid valve similar to [Figure 4-3](#). For part numbers of factory available water draw hardware kits, see Section 7.
- A plumbing setup as shown in [Figure 4-4](#). Check all valves and any threaded connections for leaks prior to beginning the water draw procedure. The plumbing setup must be leak free.
- Certified High Sensitivity (Field Standard) Test Measure traceable to the National Institute of Standards and Technology (N.I.S.T.) or other certifying agency.
- A water source with a flow rate of approximately 10 gpm (38 lpm) at 30-100 psi (207 to 689 kPa) non-fluctuating and free from entrained air.
- One digital thermometer with contact probe.
- Three (3) glass stem thermometers with 1/5 degree divisions and a range of 30 to 124°F (-1 to 50°C), traceable to the National Institute of Standards and Technology (N.I.S.T.) or other certifying agency, as applicable. One thermometer may be mounted in a temperature thief device. See [Figure 4-5](#).
- One pressure gauge, 0-100 psig range (689 kPa).
- Certification Data Sheet for recording data. Refer to [Figure 4-6](#) for example data sheet. Refer to [Section 4.3](#) for explanation of symbols.

### NOTE

1. Temperature transmitters are not recommended.
2. Factory water draw hardware kits are provided with (2) thermometers.
3. Pressure transmitters are not recommended.
4. Pressure gauges are not included in factory water draw hardware kits.

Figure 4-3 Compact prover water draw assembly typical NEC style (non-explosion proof)

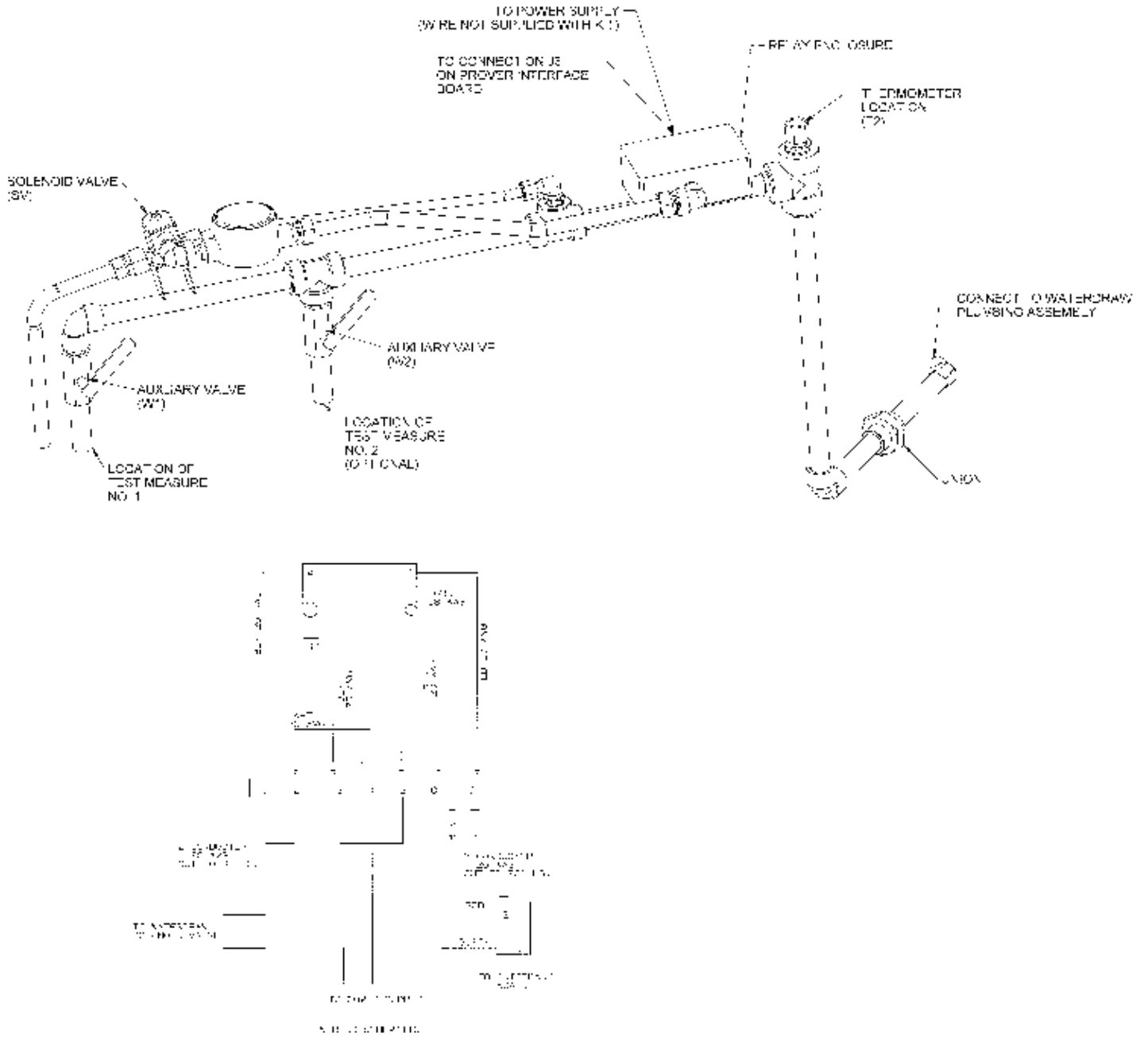

Figure 4-3 Compact prover water draw assembly (continued) Typical Ex-proof style

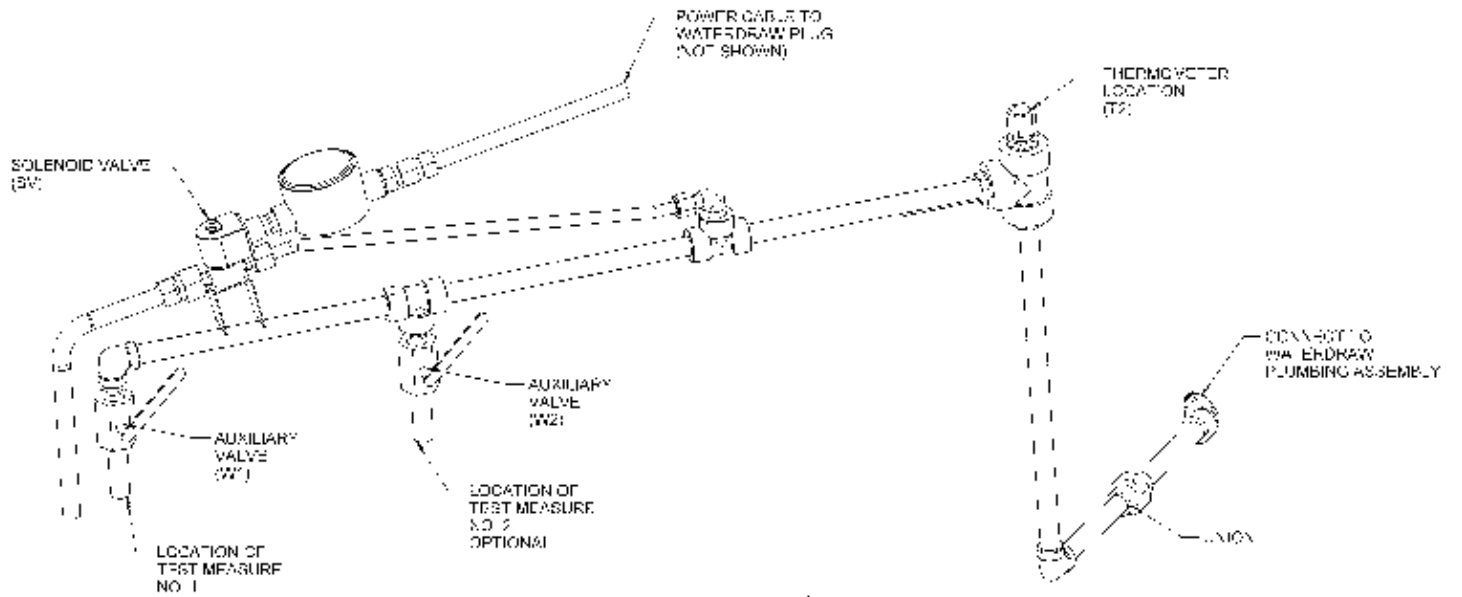
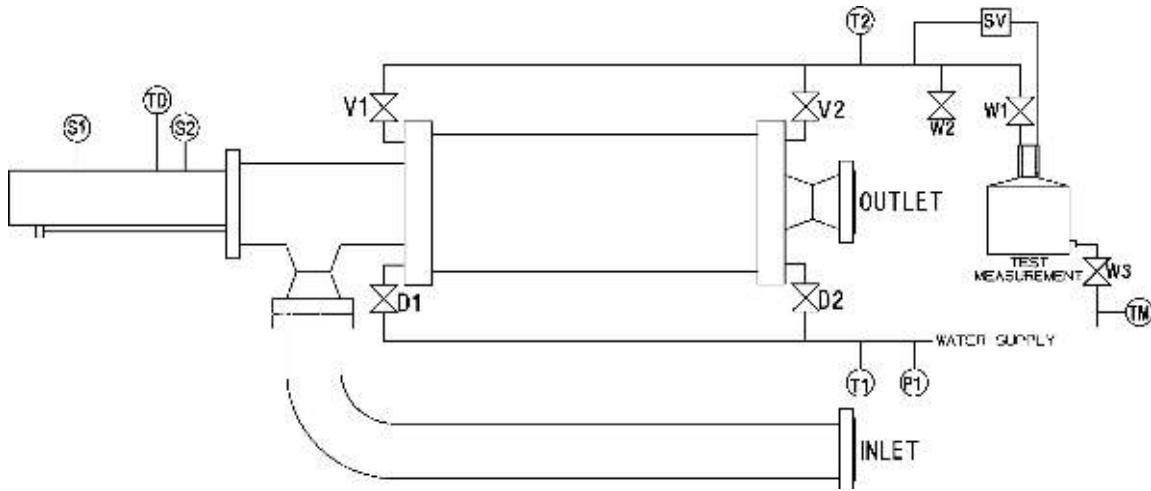

Figure 4-4 Water draw system



#### 4.2.2 Water draw procedure: (Reference Figure 4-4 and notes on page 50)

1. Isolate the prover from operational lines using double block and bleed valves or blind flanges. Verify that the prover is level. Drain and flush all process fluid from the prover. Dispose of all process fluids in an environmentally safe manner.
2. Assemble the water draw plumbing system. See Figure 4-4. All connections must be leak-free to assure proper operation. It is recommended that thread sealant be used on all pipe connections. Pipe sizing should be equal to or greater than the size of the vent and drain connections (V1, V2, D1, D2) that are supplied on the prover.
3. For factory built NEC type water draw hardware kits, connect a 3 conductor cable from the enclosure terminal block to the correct power source, 115 or 230 VAC as applicable. See Figure 4-3. The remaining 2 conductor cable, connects to receptacle J-3 on the prover Interface Board. Access to the interior of the interface enclosure will be necessary. Figure 4-7 shows the location of the interface board on the NEC-type prover electrical panel. Figure 2-3 and Figure 2-4 show the different locations possible for J-3 on the different interface boards.

For factory built ATEX and IECEx type water draw hardware kits equipped with the water draw plug, simply connect the plug to the receptacle on the control enclosure. The water draw plug and receptacle is available as an option for the NEC style factory built water draw hardware kits.

**Contact a Brodie representative for more information.**

4. Supply appropriate operational voltage (+12 or 24 VDC) to the prover interface board at receptacle J-2, pins 2 (-) and 4 (+). Reference [Section 2.4](#) to verify proper voltage required for the interface board. Reference [Figure 2-3](#) and [Figure 2-4](#) for the location of J-2.
5. Loosen and remove the cover on the optical detector switch assembly. Be careful not to damage the optical switches on removal or replacement of optical cover during the entire water draw process. See Note 4 on page 47.
6. Be sure the prover hydraulic system is connected to the appropriate AC power source. Reference the documentation package for the electrical schematic to verify proper voltage required.

Do not start the hydraulic system motor at this time. Check to see that the hydraulic tank is filled to its proper level, reference [Section 3.2](#), step 4.

7. Verify the spring plenum cut off valve is open and adjust the spring plenum pressure to approximately 75 psig (5.3 Bar).
8. The prover and water draw system must now be filled with water and cycled to purge ALL air. See Note 1 on page 47.

Open valves V1, V2, D1, D2, W1 and W3. Start the flow of water into the prover. As the prover fills with water, air will escape through valve W1. Observe the flag position.

The measurement piston will travel to the full downstream position. Once water appears at W1, set the valves for upstream flow by closing V2 and D1. Valves V1, D2, W1 and W3 remain open. Observe the flag position.

The measurement piston will now travel to the full upstream position. When water appears again at W1, reset the valves for downstream flow by opening D1 and V2, and then closing V1 and D2. After the piston reaches the full downstream position, this process should be repeated until **ALL air is removed from the system.**

9. Once all the air is removed, set the valves for downstream flow (first open V2 and D1, **then** close V1 and D2). Close valve W3 to allow the test measure to begin filling. When the test measure fills, throttle valve W3 to allow water to escape at the same rate that water is entering the test measure to maintain the water level in the test measure at or near the zero mark. Allow system to circulate until the prover and test measure temperatures are within 1/2°F (1/4°C) of each other.

Be sure this procedure places the measurement piston and flag into the full downstream position.

10. The measurement piston must now be placed into the start position for the measurement cycle.

For an Upstream water draw (procedure a): Skip to step 19.

For a Downstream (procedure b) or Combined (procedure c) water draw: Turn on the hydraulic system motor. Toggle the UPSTREAM/DOWNSTREAM switch (S2) on the interface board to the downstream position. Actuate the RUN/RETURN switch (S1) to the return position. (See Note 3 on page 47.) This will engage the hydraulic system and return the piston upstream. Reference [Figure 2-3](#) and [Figure 2-4](#).

Once the measurement piston reaches the upstream position, actuate the RUN/RETURN switch (S1) to the run position. This will release the hydraulic pressure and the measurement piston will begin traveling downstream. This will also open the solenoid valve (SV) on the water draw hardware kit. (If this water draw procedure is being repeated from step 19, valve W1 may be re-opened). When the flag nears the first optical switch (within 1" to 2"), close valve W1 while throttling valve W3 back to maintain water level in the test measure at or near the zero mark.

Replace the optical assembly cover immediately. The hydraulic system motor may now be turned off if desired.

11. Water flow into the test measure is now only through the solenoid valve (SV). When the flag enters the first optical volume switch, the solenoid valve (SV) will close and all water flow will stop. At this point, fully open valve W3 to drain the test measure and wait any specified drain time. Close valve W3.
12. Check and record the system (flow tube) pressure at P1. Actuate the RUN/RETURN switch (S1) to the run position. (See Note 3 on page 47.) This will open the solenoid valve (SV) on the water draw hardware kit and begin to fill the test measure. Open valve W1, if desired, to increase piston travel speed.
13. Record temperature measurements at T1 and T2 under flowing conditions.
14. Valve W1 must be closed before flag reaches the second optical volume switch. This can be determined by listening to the tone of the water splashing in the test measure. When the water level begins to rise into the tapered top of the test measure, the tone will rapidly increase. At this point, immediately close valve W1. When the flag enters the second optical volume switch, valve SV will close and the water flow will stop. The test measure now contains the downstream volume.

Figure 4-5 Test measure temperature stabilization

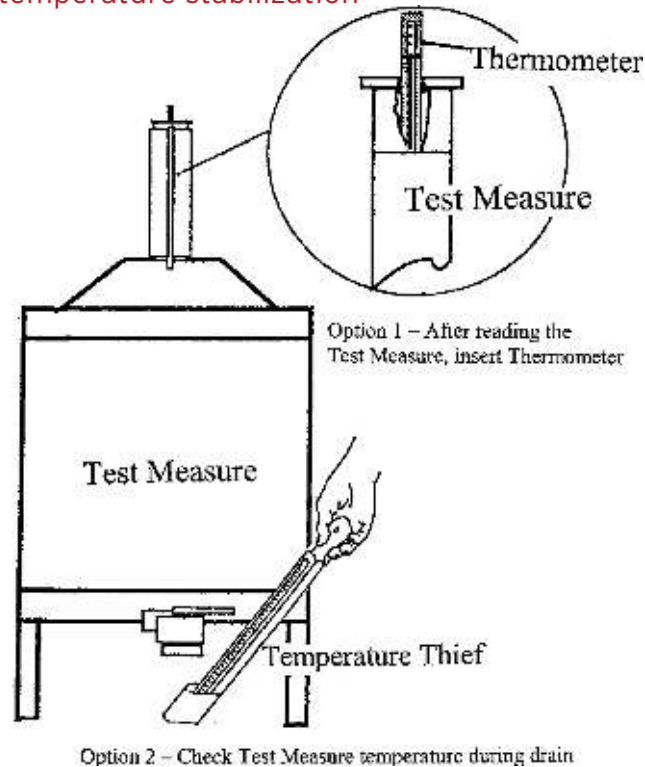

15. Slide optical assembly cover back to expose the second optical volume switch and the ends of the invar rods. Measure and record the temperature at Td (invar rod temperature) using the digital thermometer and contact probe. Replace the optical assembly cover. See Note 4 on page 47.
16. Record the water level shown on the calibrated section of the test measure. This measurement must be taken from the bottom of the meniscus inside the glass tube.
17. Record Tm, the temperature of the test measure (i.e. the water temperature inside the test measure). Open valve W3 momentarily, allowing about 1/2 gallon (2 liters) of water to drain out, and measure the temperature of the drained water with the temperature thief. (Figure 4-5).
18. Open valve W1 momentarily to replace the water drained from the test measure. This will allow the flag to proceed downstream just beyond the second optical volume switch.
19. For the Upstream (procedure a) and Combined (procedure c) water draw: Verify valve W1 is closed and reset the valves for upstream flow (V1 and D2 open; V2 and D1 closed). Proceed to step 20.
20. For the Downstream (procedure b) water draw: Return to step 10 and repeat the process for as many Downstream cycles as desired. See Note 2 on page 47. Be certain the optical assembly cover is in place and toggle the UPSTREAM/DOWNSTREAM switch (S2) on the interface board to the upstream position. Actuate the RUN/RETURN switch (S1) to the run position. (See Note 3 on page 47-14.) This will open the solenoid valve (SV) and the measurement piston will begin to move upstream. Throttle valve W3, if necessary, to maintain the water level in the test measure near the zero mark. When the flag exits the second optical volume switch, the solenoid valve (SV) will close and the water flow will stop.

21. Fully open valve W3 to drain the test measure and wait any specified drain time. Close valve W3.
22. Check and record the system (flow tube) pressure at P1. Actuate the RUN/RETURN switch (S1) to the run position. (See Note 3 on page 47.) This will open the solenoid valve (SV) on the water draw hardware kit and begin to fill the test measure. Open valve W1, if desired, to increase piston travel speed.
23. Record temperature measurements at T1 and T2 under flowing conditions.
24. Valve W1 must be closed before the flag reaches the first optical volume switch. This can be determined by listening to the tone of the water splashing in the test measure. When the water level begins to rise into the tapered top of the test measure, the tone will rapidly increase. At this point, immediately close valve W1. When the flag exits the first optical volume switch, valve SV will close and the water flow will stop. The test measure now contains the upstream volume.
25. Slide optical assembly cover back to expose the second optical volume switch and the ends of the invar rods. Measure and record the temperature at Td (invar rod temperature) using the digital thermometer and contact probe. Replace the optical assembly cover. See Note 4 on page 47.
26. Record the scale reading shown on the calibrated section of the test measure. This measurement must be taken from the bottom of the meniscus inside the glass tube.
27. Record Tm, the temperature of the test measure (i.e. the water temperature inside the test measure). See [Figure 4-5](#). Open valve W3 momentarily, allowing about 1/2 gallon (2 liters) of water to drain out, and measure the temperature of the drained water with the temperature thief.
28. Open valve W1 momentarily to replace the water drained from the test measure. This will allow the flag to proceed upstream just beyond the first optical volume switch.
29. For the Upstream (procedure a) water draw: The measurement piston must be moved to the downstream position. Close valve D2, and open valves V2 and D1. This will allow the measurement piston to move downstream. Observe the flag position until the piston reaches the full downstream position and replace the optical cover. Proceed from step 19 for as many Upstream measurement cycles as desired. See Note 2 on page 47.

For the Combined (procedure c) water draw: Reset the valves for downstream flow (V2 and D1 open; V1 and D2 closed) and continue to step 30.

30. Toggle the UPSTREAM/DOWNSTREAM switch (S2) on the interface board to the downstream position. Actuate the RUN/RETURN switch (S1) to the run position. (See Note 3 on page 47.) This will open the solenoid valve (SV) and the measurement piston will begin to move downstream. Throttle valve W3, if necessary, to maintain the water level in the test measure near the zero mark. When the flag enters the first optical volume switch, the solenoid valve (SV) will close.

31. Fully open valve W3 to drain the test measure and wait any specified drain time. Close valve W3. At this point, actuating the RUN/RETURN switch (S1) will begin the next measurement cycle. (See Note 3 on page 47.) The procedure may now be repeated from step 12 for as many Combined water draw cycles as desired. See Note 2 on page 47.

**NOTES for water draw procedures:**

1. Once the water draw displacement procedure is started it should be carried to conclusion in a continuous process without interruption or delay.
2. One measurement cycle of the water draw process must be performed with the flow rate reduced 25 to 50%. This may be accomplished by throttling valve W1. This is typically performed for the second cycle.
3. Run/Return and Upstream/Downstream selector switches are labeled S1 and S2 (respectively) on the Interface Board itself. Provers equipped with the optional water draw plug, have these switches operational to the front of the control enclosure, or interface enclosure (as applicable). Labels on the front of the enclosure will dictate the switch operation for water draw purposes.
4. The optical cover should be replaced for each measurement cycle. However, it does not have to be fastened permanently each time. Simply slip the cover completely over the optical assembly to black out any ambient light that could alter optical switch operation.
5. Once the water draw procedure is completed, replace the optical cover and follow the procedure in [Section 2.4](#).



**Compact Prover Volumetric Calibration Data Sheet**  
**Brodie International, Statesboro, Ga. USA**

This form is a supplement to Certification Number \_\_\_\_\_

Customer: \_\_\_\_\_ Date: \_\_\_\_\_  
 Serial No.: \_\_\_\_\_ Nit. Tank Serial No.: \_\_\_\_\_  
 Model No.: \_\_\_\_\_  
 Cust. Order No.: \_\_\_\_\_  
 Calibrated Measure's Volume \_\_\_\_\_ mL in3  
 Test Measure NIST Seal #: \_\_\_\_\_ (Circle One)

Units of Measure: Temp °C °F Pressure kPa psig Scale Increments \_\_\_\_\_ mL in3

		Downstream Volume Runs				
		1	2	3	4	5
Water Temp	Inlet (T1)					
	Outlet (T2)					
Prover Temp (Tp)						
Test Measure Temp (Tm)						
Sensor Mounting Temp (Td)						
Water Pressure (P)						
Test Measure Scale Reading						
Pass Time (sec)						

		Upstream Volume Runs				
		1	2	3	4	5
Water Temp	Inlet (T1)					
	Outlet (T2)					
Prover Temp (Tp)						
Test Measure Temp (Tm)						
Sensor Mounting Temp (Td)						
Water Pressure (P)						
Test Measure Scale Reading						
Pass Time (sec)						

Tp = SVP water temperature, Average of T1 and T2  
 Tm = Temperature of water in Test Measure  
 P = Water pressure during test draw  
 Td = Temperature of Displacer position sensors

Pre-Test Inspection

- Inspect Gauges
- Inspect Test Measure
- Check Expiration Dates

**Calibration Identification Numbers**

Inlet Thermometer \_\_\_\_\_  
 Outlet Thermometer \_\_\_\_\_  
 Tank Thermometer \_\_\_\_\_  
 Sensor Thermometer \_\_\_\_\_  
 Pressure Gauge \_\_\_\_\_

**Calibrator** \_\_\_\_\_

**Witness** \_\_\_\_\_

**Leak Detector Test Results (2 places)**

\_\_\_\_\_ Inches in \_\_\_\_\_ Minutes  
 \_\_\_\_\_ Inches in \_\_\_\_\_ Minutes

Figure 4-7 Typical prover control panel assembly (12" shown)

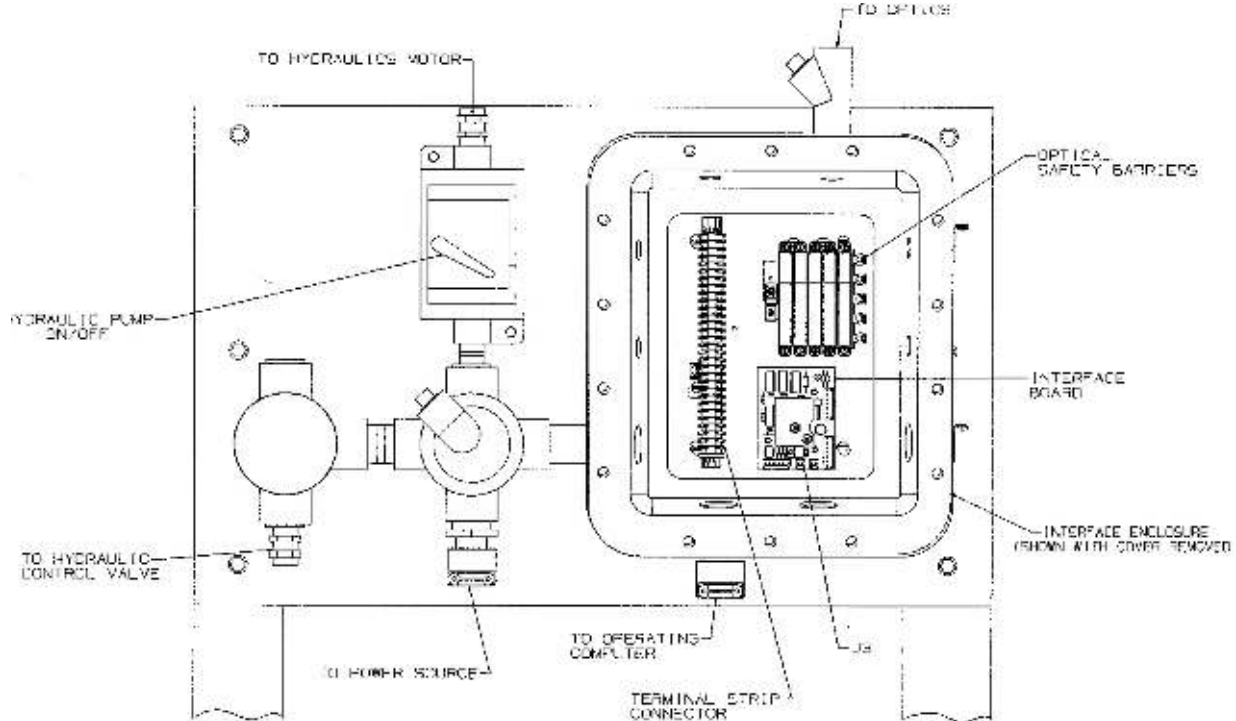

## 4.3 Certification Data Sheet and Calculations

### 4.3.1 Data Sheet Entries

The following is a step-by-step procedure for using the Volumetric Determination Data Sheet to obtain the base volume of the prover, adjusted (corrected) to reference conditions.

An example of a typical data sheet is shown in [Figure 4-6](#).

Record the following variables on a data sheet for each measurement cycle as defined below:

- 1. Water Inlet Temperature (T1):** The temperature of the water as it enters the prover.
- 2. Water Outlet Temperature (T2):** The temperature of the water as it exits the prover.
- 3. Prover Temperature (Tp):** The average of T1 and T2.
- 4. Test Measure Temperature (Tm):** The temperature of the water in the test measure. This is measured with the temperature thief during the water draw procedure.
- 5. Sensor Mounting Temperature (Td):** This is the temperature of the Invar Rods used for spacing the optical switches. The temperature is measured during the water draw procedure. As an option, ambient temperature may be used.
- 6. Water Pressure (P):** The pressure recorded from the pressure gage of the water draw system.
- 7. Test Measure Scale Reading:** Actual measurement recorded from the calibrated section of the test measure. This is a + or - reading from the zero mark.

### 4.3.2 Calculations

The following formula will be used in the process of calculating the Compact Prover base volume at reference conditions:

1. **V<sub>tp</sub>**: The corrected prover volume at reference conditions.
2. **V<sub>m</sub>**: The stated volume of the test measure, plus or minus the scale reading recorded on the data sheet from the water draw.
3. **T<sub>mp</sub>**: Volumetric correction factor for differences between the prover and the test measure temperatures as found in American Petroleum Institute (API) Chapter 11.2.3(m) Water Certification of Volumetric Provers.
4. **C<sub>ss</sub>**: This is the correction factor for the temperature of the stainless steel test measure, the carbon (or stainless steel) flow tube, and the Invar rods. The correction factor is determined using the following formula:

$$C_{ss} = \frac{1 + (T_m - T_b)E_{tm}}{[1 + (T_p - T_b)E_{ft}][1 + (T_d - T_b)E_{ir}]}$$

#### Where:

**T<sub>m</sub>** is the temperature of the test measure recorded from the water draw procedure using the temperature thief.

**T<sub>b</sub>** is the reference temperature.

**E<sub>tm</sub>** is the cubical coefficient of expansion of the stainless steel test measure depending on temperature units being used: 0.0000265/°F or 0.0000477/°C. The manufacturer of the test measure will also give this value that may be used if desired for improved accuracy.

**T<sub>p</sub>** is the temperature of the prover. This is the average of T1 and T2.

**E<sub>ft</sub>** is the squared coefficient of expansion used for the flow tube. This number will vary depending on the material of the flow tube.

	°F	°C
Carbon steel	0.0000124	0.0000223
17-4 Stainless steel	0.0000120	0.0000216
Cast 304 Stainless Steel	0.0000177	0.0000319
304 Stainless Steel	0.0000192	0.0000346
32205 Duplex	0.0000152	0.0000274

**T<sub>d</sub>** is the Sensor Mounting Temperature recorded from the water draw procedure.

**E<sub>ir</sub>** is the linear coefficient of expansion for the Invar Rods. This value is based on the temperature units used and will be 0.0000008/ °F or 0.00000144/ °C.

5. **C<sub>pl</sub>**: This is the compressibility reduction factor for water. This factor is determined by the following formula:

$$C_{pl} = \frac{1}{1-(0.0000032 \cdot P)}$$

Where P is the pressure recorded at P1 during the water draw procedure in psig, or

$$C_{pl} = \frac{1}{1-(0.000000464 \cdot P)}$$

Where P is the pressure recorded at P1 during the water draw procedure in Bar

6. **C<sub>ps</sub>**: This is the correction factor for the expansion of the flow tube due to pressure. This factor is determined by the following formula:

$$C_{ps} = 1 + \frac{P \cdot D}{E \cdot t}$$

**Where:**

**P** is the pressure recorded at P1 during the water draw procedure.

**D** is the inside diameter of the flow tube.

**E** is the Modulus of elasticity for the material of the flow tube. If pressure is measured in psi, this value will be 28,500,000 for stainless steel and 30,000,000 for carbon steel. If pressure is measured in Bar, the Modulus of elasticity for stainless steel will be 196,500,574.5, 206,842,710 for carbon steel, and 200,000,000 for 2205 duplex stainless steel.

**t** is the wall thickness of the flow tube. Be sure to use identical units of measure for the thickness as used for the diameter of the flow tube.

**V<sub>tp</sub>** must be calculated for each set of data collected during each measurement cycle of the water draw procedure.

The **downstream base volume** will be the average of the corrected volumes (V<sub>tp</sub>'s) of the downstream cycles of the water draw. The repeatability of the downstream corrected volumes must be within .02%, see formula below. Enter the downstream base volume into the operating computer if the meter under test is located downstream of the prover.

The **upstream base volume** will be the average of the corrected volumes (V<sub>tp</sub>'s) of the upstream cycles of the water draw. The repeatability of the upstream corrected volumes must be within .02%, see formula below. Enter the upstream base volume into the operating computer if the meter under test is located upstream of the prover.

$$\text{repeatability (\%)} = \frac{\text{highest } V_{tp} - \text{lowest } V_{tp}}{\text{lowest } V_{tp}} \cdot 100$$

## 4.4 Seal Replacement

Should the seals within the Compact Prover ever need to be replaced, the procedures in this section will guide the qualified technician through a simple step by step process. Before attempting any repair or disassembly procedures, the following details must be observed:

- Disconnect power to the operating computer and the prover. This will prevent accidental power up of the prover hydraulics and electronics.
- Disconnect, or isolate, the prover from the process line (pressure and flow).
- Drain all fluid from the flow tube by opening the drain and vent valves located at the top and bottom of the end flanges on each end of the flow tube. Dispose of any process fluids in an environmentally safe manner.

### 4.4.1 Measurement Piston and Flow Tube

To determine if the measurement piston seals need inspection for possible replacement, perform the leak test as described in [Section 4.1](#). If line product is leaking from either end of the flow tube (between the flow tube and end flanges), the flow tube seals in the end flanges are in need of inspection for possible replacement.

There are two methods for measurement piston and flow tube seal replacement. Procedure A will be necessary if a complete tear-down of the prover is required. Procedure B will be necessary if only the piston and flow tube seals are in need of replacement.

Procedure A: Piston and Flow Tube Disassembly  
Reference [Figure 7-2, Section 7: Parts list](#).

1. Disassemble the optical and hydraulic systems following the appropriate disassembly instructions. See [Section 4.4.2](#) and [Section 4.4.3](#) respectively.
2. Slide a piece of plastic tubing, approximately 2 feet longer than the flow tube, over the actuator shaft and remove the optical detector shaft from the threaded mounting boss.
3. Attach the outlet flange to a hoist and support the flange so that it will be held in place when the tie rods are removed.
4. Make sure that the support saddles below the flow tube will hold it in position without allowing it to drop when the outlet flange is removed. Adjust if necessary.
5. Remove the tie rod nuts securing the outlet flange assembly.
6. Remove the outlet flange.
7. Use the tube protecting the actuator rod to push the measurement piston to the end of the flow tube. **DO NOT PUSH THE MEASUREMENT PISTON OUT OF THE FLOW TUBE.**
8. Using sufficient personnel (at least 2), pull the measurement piston out of the flow tube. Be sure to support the weight of the piston as it is removed from the flow tube. This will keep the actuator shaft from damaging the flow tube.
9. After removal, support the piston in such a way as to prevent the piston weight from resting on the seals on the front of the measurement piston.
10. Press the poppet valve open and secure it in position using a wooden block or non-marring dowel.
11. Remove the o-ring from the groove in the poppet valve. Removal of the poppet valve at this time will ease replacement of the poppet seal.
12. Remove the piston seals and rulon riders.
13. Carefully clean and examine the flow tube bore for scoring, corrosion or other signs of wear or damage. Consult the factory concerning replacement.
14. Remove the tie rods from the prover excluding the two tie rods at the bottom. These may remain in place.
15. Lift the flow tube slightly off the support saddles. Pull it away from engagement with the inlet flange. A hoist will be necessary for this operation.
16. Remove the inlet and outlet flange o-rings and inspect for damage.

### Procedure A: Piston and Flow Tube Assembly

In the following procedure where lubrication of parts is recommended, it should be noted that excessive amounts of lubrication should be avoided as the base volume of subsequent water draw could be affected.

1. If the upstream flow tube o-ring is to be replaced, install the new o-ring in its groove using lubricant (white lithium grease) to hold in place.
2. Install the flow tube on its saddles, flush against the inlet flange. Adjustment of the saddles may be necessary.

3. Place the pieces of guide conduit (used in disassembly) through the upstream flange and flow tube.
4. Lubricate the poppet valve o-ring and fit it onto the groove in the poppet valve. It is recommended that the o-ring be pressed into the groove in places 90. apart to help eliminate any twisting or stretching. See [Figure 4-8](#). Care must be taken when working the seal into the poppet groove as the seal may stretch and not seat correctly. The use of a smooth plastic tool may assist in working the seal into the poppet groove. Working the seal on opposite sides of the groove every few inches will assist in proper installation. Use care to prevent damage to the o-ring.

Figure 4-8 Poppet O-ring installation

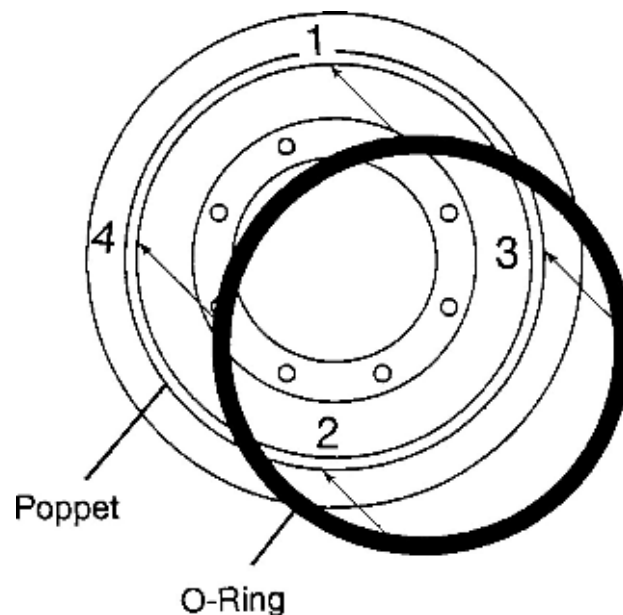

- If the poppet valve has been removed from the measurement piston, install it at this time. Torque the poppet bolts.

Table 4-1 Torque table

Prover Size	Poppet Bolt Size	Torque Requirement	
		ft-lbs	Nm
8"	1/4 - 20	6	8
12" Mini	3/8 - 16	15	20
12"	3/8 - 16	15	20
18"	3/8 - 16	15	20
24"	1/4 - 20	6	8
	1/2 - 20	25	34
34"	3/8 - 16	15	20
40"	1/2 - 13	25	34

**NOTE**

For high temperature 2 piece poppets, the 3/8-24 screw requires 24 ft.lbs (33 Nm) torque

- Lubricate the two measurement piston seals with light oil and install them on the piston. The open sides of the two seals will be facing away from each other when installed correctly. Each seal will require proper fitting. Once the seal is around the groove, the seal must be pushed into the groove. A 'snap' will be heard once the seal seats in the groove. Be sure to check that the entire seal is properly seated.
- Test fit of the rulon riders on the measurement piston. Trim any excess length so that there will be a 1/16" (2 mm) gap between the ends of each rider. Remove the riders from the piston and lay them over the end of the flow tube.

**IMPORTANT**

The 12" Compact Prover has two different sized riders; a thick rider and a thin rider. The thick rider fits in the upstream groove of the piston. The thin rider fits in the downstream groove of the piston, between the two piston seals. All other size provers have identical riders.

- Lubricate the inside of the flow tube with light oil. Align the measurement piston with the flow tube and insert the actuator shaft into the guide conduit. Pay attention to the threaded mounting boss (for the detector shaft) and align as necessary.
- Carefully insert the measurement piston into the flow tube until the first rulon rider groove is about to go into the flow tube. Install the first rulon rider onto the measurement piston with the gap at the bottom of the piston. Lubricate the rider with light oil.

10. Slide the measurement piston into the flow tube up to the upstream seal. Lubricate the upstream seal with light oil. If the upstream seal is installed correctly, the seal should slip into the flow tube when gently pressing on the piston.
11. Press the measurement piston into the flow tube until the second rulon rider groove is about to go into the flow tube. Install the second rider onto the piston with the gap at the bottom of the piston. Lubricate the rider with light oil.
12. Press the piston into the flow tube past the second rulon rider and up to the downstream seal. Lubricate the downstream seal with light oil. Gently press on the poppet until the downstream seal slips into the flow tube.
13. Using a flashlight, look through the hole in the inlet flange where the optical detector shaft goes through. Check the alignment of the threaded mounting boss on the piston. The boss must be aligned with this hole in the inlet flange for correct installation of the detector shaft. Rotate the piston if necessary to align the boss.
14. Remove the guide conduit from the actuator shaft. Pull the actuator shaft out from the tee of the inlet flange until the piston is approximately half way inside the flow tube. Recheck the alignment of the mounting boss on the piston with the hole in the inlet flange for the detector shaft.

If realignment is necessary, the poppet must be used to 'tap' the piston into position. Pull on the actuator shaft enough to open the poppet. Spin the actuator shaft, in the direction necessary for alignment, when slightly pushing the poppet against the piston. This will make the poppet 'tap' on the piston and move the piston into alignment. It may be necessary to repeat this procedure to align the threaded mounting boss correctly.

15. Install the detector shaft into the threaded mounting boss and tighten by hand. At this point, it is recommended to install the optical seal support over the detector shaft. This holds the piston in alignment for the remainder of the assembly procedures. See [Section 4.4.2](#) for optical seal support assembly and installation.
16. Install the o-ring in the groove of the outlet flange using lubricant to hold it in place.
17. Lift the outlet flange with a hoist and align it on the end of the flow tube. Insert four (4) tie rods through the flow tube flanges that are diagonal from each other.
18. Install the tie rod nuts to the four tie rods and tighten them to pull the flow tube and the outlet flange snug against the inlet flange. Pay attention to the o-rings in the end flanges and be certain they remain in place. Care should be taken to avoid scraping paint into the space between the flanges and the flow tube.
19. Install the remaining tie rods and nuts. Tighten nuts enough to bring the flanges and flow tube together.
20. Check the alignment of the outlet flange with the inlet pipe flange. A standard level and the installation studs (for the outlet flange) may be useful. Rotation of the outlet flange will bring the bolt pattern into alignment.
21. Torque the tie rod nuts to the values specified in [Table 4-2](#) for the proper prover size. Torque all the tie rod nuts in a 'criss-cross' pattern.

22. Follow the appropriate assembly procedures for installation of the hydraulic seal support, hydraulic cylinder, optical seal support, and optical assembly.  
See Section 2.4, Section 4.4.2 and Section 4.4.3.
23. It is recommended that the leak check procedure be performed after seal replacement to assure that the measurement piston seals are working correctly.  
See Section 4.1.
24. A hydrostatic pressure test is also recommended following the re-assembly of the Compact Prover.

Table 4-2 Tie rod nut torque

Prover Size	Nut Size	Torque Requirement					
		150		300		600	
		ft-lbs	Nm	ft-lbs	Nm	ft-lbs	Nm
8"	3/4"	115	156				
	1"	153	208	396	537	396	537
12" mini	1"	159	216	412	559		
	1-3/8"					906	1230
12"	1"	127	172	330	448		
	1-3/8"					906	1230
18"	1-1/4"	389	528	1008	1368		
	1-1/2"					2351	3188
24"	1-1/4"	807	1095				
	1-1/2"	646	877	1675	2273		
	1-5/8"					3734	5067
	1-7/8"					3140	4261
34"	2"	1521	2064	3945	5353	n/a	n/a
40"	2"			4168	5656	n/a	n/a

### Procedure B: Piston and Flow Tube Disassembly

1. Place the measurement piston in the full upstream position. Close nitrogen valve.
2. Attach the outlet flange to a hoist and support the flange so that it will be held in place when the tie rods are removed.
3. Make sure that the support saddles below the flow tube will hold it in position without allowing it to drop when the outlet flange is removed. Adjust if necessary.

4. Remove the tie rod nuts securing the outlet flange assembly.
5. Remove the outlet flange and then all but the lower two tie rods.
6. Using a hoist, support the flow tube. Take care to keep the flow tube level to prevent damage to the piston, actuator shaft, and detector shaft.
7. Keeping the flow tube level, slide the flow tube off the piston.
8. After removal, support the piston in such a way as to prevent the piston weight from resting on the seals of the hydraulic seal support or the optical seal support.
9. Press the poppet valve open and secure it in position using a wooden block or non-marring dowel.
10. Remove the o-ring from the groove in the poppet valve. Removal of the poppet valve at this time will ease replacement of the poppet seal.
11. Remove the piston seals and rulon riders.
12. Carefully clean and examine the flow tube bore for scoring, corrosion or other signs of wear or damage. Consult the factory concerning replacement.

### Procedure B: Piston and Flow Tube Assembly

1. In the following procedures where lubrication of parts is recommended, it should be noted that excessive amounts of lubrication should be avoided as the base volume of subsequent water draw could be affected.
2. Lubricate the poppet valve o-ring and fit it onto the groove in the poppet valve. It is recommended that the o-ring be pressed into the groove in places 90° apart to help eliminate any twisting or stretching. See [Figure 4-8](#). Care must be taken when working the seal into the poppet groove as the seal may stretch and not seat correctly. The use of a smooth plastic tool may assist in working the seal into the poppet groove. Working the seal on opposite sides of the groove every few inches will assist in proper installation. **Use care to prevent damage to the o-ring.**
3. If the poppet valve has been removed from the measurement piston, install it at this time. See [Table 4-1](#) for torque values.
4. Lubricate the two measurement piston seals with light oil and install them on the piston. The open sides of the two seals will be facing away from each other when installed correctly. Each seal will require proper fitting. Once the seal is around the groove, the seal must be pushed into the groove. A 'snap' will be heard once the seal seats in the groove. Be sure to check that the entire seal is properly seated.
5. Test fit of the rulon riders on the measurement piston. Trim any excess length so that there will be a 1/16" (2 mm) gap between the ends of each rider. Remove the riders from the piston and lay them aside for later use.

## IMPORTANT

The 12" compact prover has two different sized riders; a thick rider and a thin rider. The thick rider fits in the upstream groove of the piston. The thin rider fits in the downstream groove of the piston, between the two piston seals. All other size provers have identical riders.

6. Lubricate the inside of the flow tube with light oil. Align the flow tube with the measurement piston.
7. Carefully slide the flow tube over the measurement piston until the first seal goes into the flow tube. Take care to prevent the seal from folding backwards during this process. Install the first rulon rider onto the measurement piston with the gap at the bottom of the piston. Lubricate the rider with light oil.
8. Slide the flow tube over measurement piston up to the rear rider. The second piston seal should slip into the flow tube without fail.
9. Install the second rulon rider onto the measurement piston with the gap at the bottom of the piston. Lubricate the rider with light oil.
10. Press the flow tube over the measurement piston until the second rulon rider goes into the flow tube.
11. Slide the flow tube up to the upstream flange.
12. Install the o-ring in the groove of the outlet flange using lubricant to hold it in place.
13. Lift the outlet flange with a hoist and align it on the end of the flow tube. Insert four (4) tie rods through the flow tube flanges that are diagonal from each other.
14. Install the tie rod nuts to the four tie rods and tighten them to pull the flow tube and the outlet flange snug against the inlet flange. Pay attention to the o-rings in the end flanges and be certain they remain in place. Care should be taken to avoid scraping paint into the space between the flanges and the flow tube.
15. Install the remaining tie rods and nuts. Tighten nuts enough to bring the flanges and flow tube together.
16. Check the alignment of the outlet flange with the inlet pipe flange. A standard level and the installation studs (for the outlet flange) may be useful. Rotation of the outlet flange will bring the bolt pattern into alignment.
17. Torque the tie rod nuts to the values specified in [Table 4-2](#) for the proper prover size. Torque all the tie rod nuts in a 'criss-cross' pattern.
18. It is recommended that the leak check procedure be performed after seal replacement to assure that the measurement piston seals are working correctly. See [Section 4.1](#).
19. A hydrostatic pressure test is also recommended following the re-assembly of the compact prover.

## 4.4.2 Optical Seal Support

To determine if the optical seal support is in need of repair, check the weep hole at the bottom of the seal support. If line product is leaking from the weep hole, the seals internal to the support should be inspected for possible replacement.

### Disassembly

Reference [Figure 4-9](#).

1. Remove the bracket securing the optical switch cover.
2. Remove the optical switch cover and o-ring.
3. Disconnect the main plug to the optical switch wiring harness near the seal support. Remove the 'hoop style' wire anchor that holds it to the optical frame.
4. Loosen the clamping screws that hold the flag assembly to the detector shaft.
5. Carefully slide the flag assembly off of the shaft. DO NOT damage or disturb the position of the optical switches. Be careful not to strike them with the flag when it is removed.
6. Remove the optical assembly by removing the four (4) socket head screws holding it to the seal support. Temporarily place the optical assembly where it will not get damaged.

### WARNING

#### HIGH PRESSURE HAZARD

**Release all pipeline/process fluid pressure from the prover.**

Failure to do so may result in serious personal injury.

7. Remove the three (3) socket head screws from the optical seal support that hold it to the inlet flange. Remove the seal support and o-ring by carefully sliding it off the detector shaft. Inspect for wear or damage.

**TIP** If the conduit connection to the optical seal support needs to be removed, loosen the clamping nut on the blue conduit and remove the connection pins from inside the wiring harness plug described in step 3. A small pointed utensil may be used for this. Once the wires are removed from the plug, the wires may be pulled out of the seal support. Do not remove the clear tubing protecting the wires in the seal support.

Figure 4-9 Optical seal support assembly - 8" through 18" and 24" units built prior to January 1, 2006

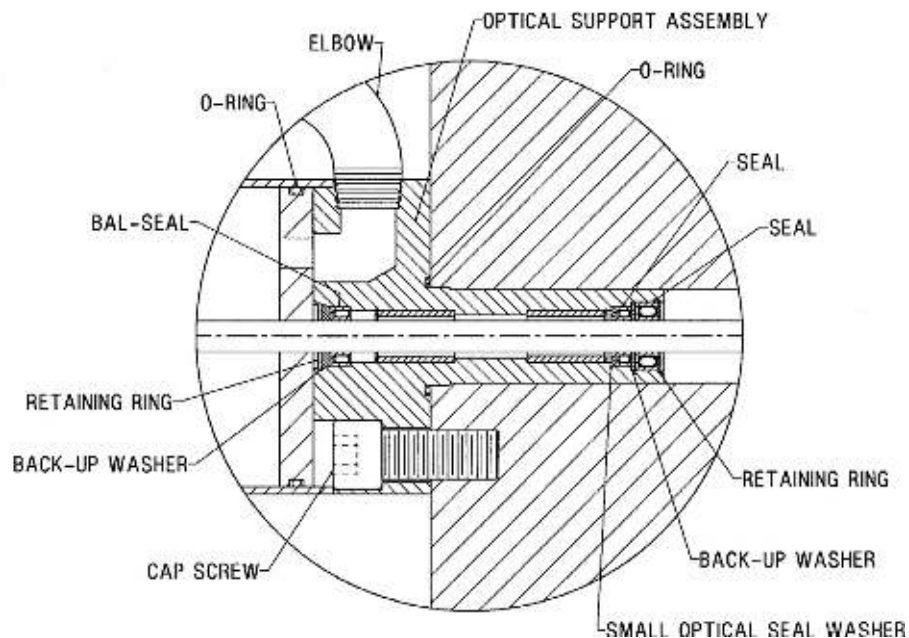

8. Referring to [Figure 4-9](#) or [Figure 4-10](#), whichever is applicable, remove the retaining rings, seals, and back-up washers from the optical seal support. Inspect for wear or damage.
9. Clean all parts (except electrical assemblies) in a suitable solvent as required and inspect for signs of abnormal wear, corrosion, cracking, etc.
10. Inspect optical shaft for nicks, scratches, galling or build up of contaminants. Polish with 400 grit or finer sandpaper with water and wipe with solvent as required.
11. Check the rulon bushings in the optical seal support for clearance on the optical shaft. Correct clearance is .0015 to .005 inch (.038 to .127 mm). If clearance is excessive consult the factory concerning replacement.

Figure 4-10 Optical seal support assembly - 24" (built after January 1, 2006) and 34"

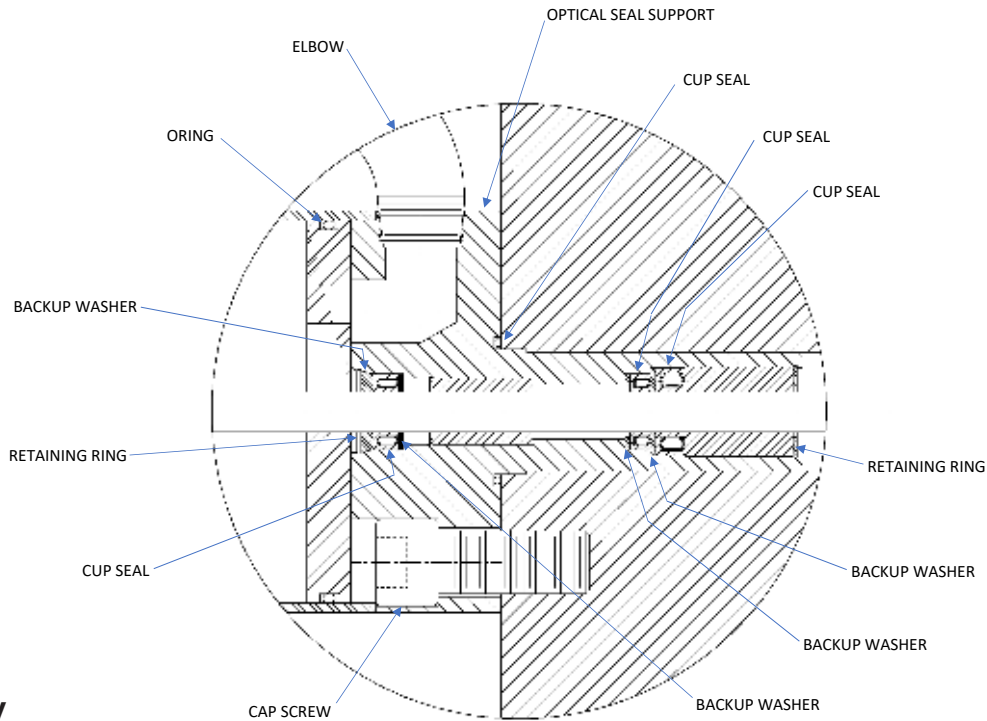

## Assembly

Reference [Figure 4-9](#) and [Figure 4-10](#)

1. On the smaller diameter end of the optical seal support, install the small optical seal washer, the small bal-seal, the backup washer, the larger bal-seal and retaining ring in that order. The open ends of all seals are to face into the flow tube. On the opposite end, install the bal-seal and the backup washer. Secure with the retainer ring.
2. Install the o-ring on the optical seal support.
3. Install the optical seal support assembly to the inlet flange using the three (3) socket head cap screws. Pay attention to the location of the modified cap screw, which is located across from the conduit elbow.

## NOTE

If the wiring harness plug was removed during disassembly, reinstall the wires and plug at this point. The mating harness plug on the optical assembly may be used as reference to install the wires back into the plug. Make the wire colors match one another. Slightly bend the retaining clip out if necessary to make the pins fit securely. A 'snap' sound will be heard when the pins are in place.

4. Slide the flag back and forth along the optical assembly checking to assure that it passes through the center of each optical switch. Adjust if necessary.
5. Slide the optical assembly and the flag over the detector shaft. Install the optical assembly to the seal gland using the four (4) socket head cap screws. Pay attention to the location of the small cap screw.
6. Place the piston in the full upstream position.
7. Center the flag in the upstream switch then tighten the clamp screws. The flag should be firmly clamped to the detector shaft.

8. After achieving proper alignment of the optical system, install the o-ring and the cover tube. The cover should be positioned with the boss on the side.
9. Install the brace from the support bar to the optical assembly.
10. If calibration is required, proceed to [Section 4.4.2](#), if not, see [Section 2.4](#).

#### 4.4.3 Hydraulic Cylinder and Hydraulic Seal Support

To determine if any of the seals in the hydraulic cylinder or the hydraulic seal support are in need of replacement, check the weep hole at the bottom of the seal support. If line product is leaking from the weep hole, the support seals are in need of replacement. If there is hydraulic fluid leaking from the weep hole, the seals internal to the hydraulic cylinder are in need of inspection for possible replacement.

#### Disassembly

References [Figure 4-11](#) and [Figure 4-12](#)

[Figure 4-11](#) Hydraulic seal support assembly

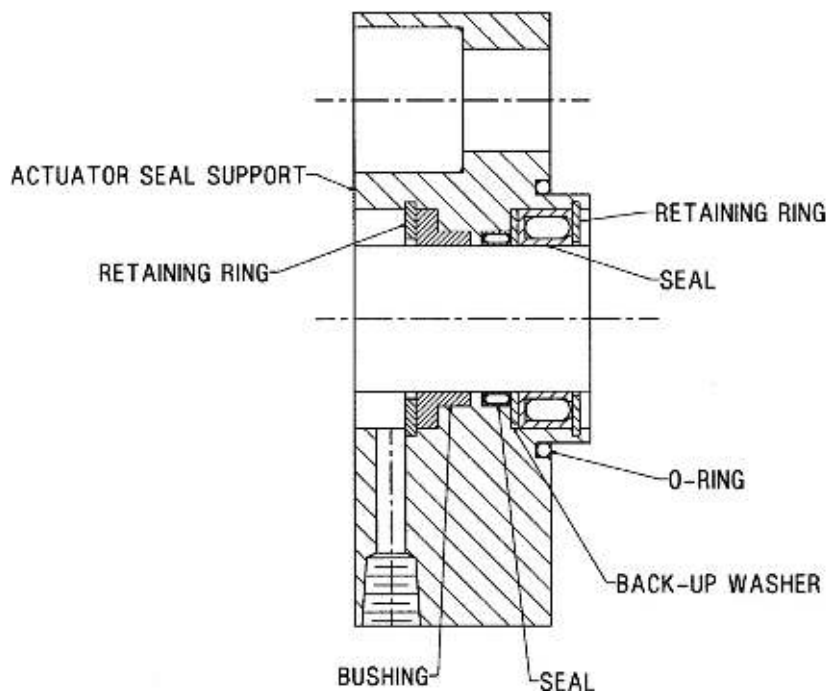

1. Close the spring plenum shut-off valve to the hydraulic cylinder and remove the valve's handle. This will prevent accidental opening of the spring plenum and loss of the nitrogen within.
2. Loosen the Nitrogen supply line at the end of the hydraulic cylinder. Allow the gas in the supply line to escape.

3. Disconnect the Nitrogen supply line from the hydraulic cylinder.
4. Drain the hydraulic fluid from the hydraulic cylinder by disconnecting the pressure hose from the hydraulic pump. **If the fluid is caught in a clean container, it may be reused. If the fluid is not to be reused, disposal should be done in an environmentally safe manner.**
5. Remove the four nuts securing the upstream flange of the hydraulic cylinder.
6. Remove the support bracket holding the upstream end of the hydraulic cylinder.
7. Remove the upstream flange and o-ring from the actuator cylinder.
8. Remove the four hydraulic cylinder tie rods. If the rods cannot be removed by hand, install two nuts, tighten them together and use a wrench on the inner nut to unscrew the rod.
9. Remove the hydraulic cylinder tube and o-ring taking care not to damage the actuator piston or cylinder tube. Oil will drain from the cylinder as it is pulled from its' downstream flange.
10. Remove the lock nut attaching the actuator piston. An impact wrench is recommended for this step. However, if one is not available the strap wrench listed in Section 6.1 may be used to hold the actuator shaft while a wrench is used to remove the actuator piston nut.

### **IMPORTANT**

**Do not damage the outer surface of the actuator shaft.**

Damaging the actuator shaft may result in seal damage.

11. Remove the actuator piston and cushion. Care should be taken when removing the piston from the actuator shaft, as there is an o-ring inside the piston. Remove the actuator piston as if unthreading a nut from a screw.

Figure 4-12 Typical hydraulic cylinder assembly

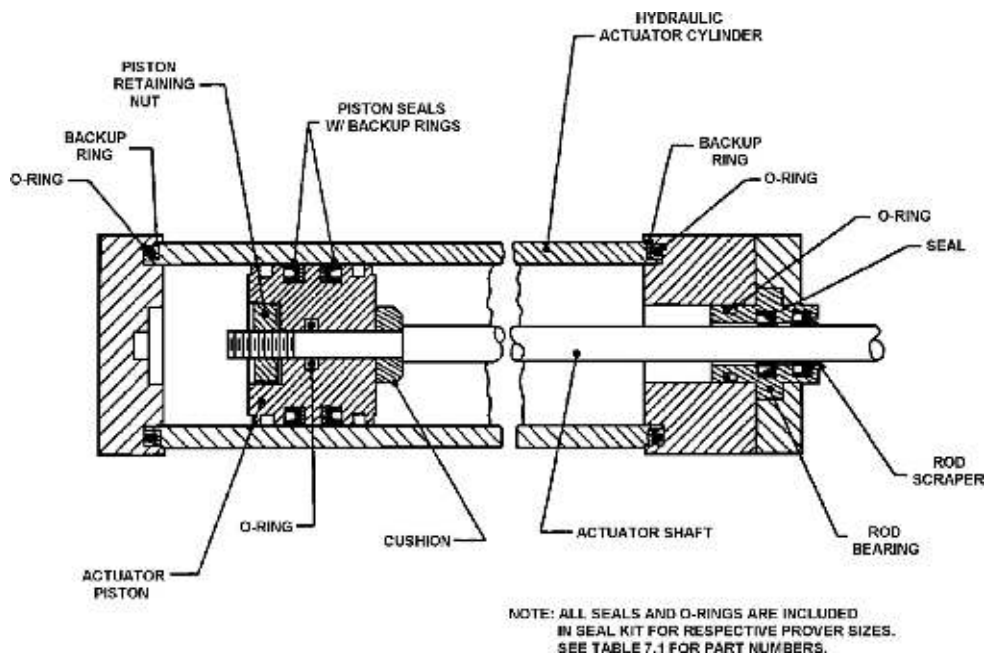

12. Remove the hydraulic lines from the downstream flange of the hydraulic cylinder.
13. Remove the downstream flange of the hydraulic cylinder. Some prover sizes will require the removal of mounting screws for this flange.

**WARNING**

**HIGH PRESSURE HAZARD**

**Release all pipeline/process fluid pressure from the prover.**

Failure to do so may result in serious personal injury.

14. Remove the socket head screws attaching the actuator seal support to the tee of the inlet flange. Remove the actuator seal support by carefully sliding it off the actuator shaft.
15. Referring to [Figure 4-11](#), remove the retaining ring, seals and back-up washer from the actuator seal support. Determine the suitability of the backup washer for reuse.
16. Clean all parts in a suitable solvent as necessary and inspect for signs of abnormal wear, corrosion, cracking etc.
17. Inspect the actuator shaft for nicks, scratches, galling, or build up of contaminants. Polish with 400 grit or finer sandpaper (emery cloth) and water. Wipe with solvent as needed.

18. Check the bushing in the actuator seal support for clearance on the actuator rod. Correct clearance is .002 to .005 inch (.051 to .127 mm). If clearance is excessive, consult the factory for replacement.

## Assembly

In the following procedure where lubrication of parts is recommended, it should be noted that excessive amounts of lubrication should be avoided as the base volume of subsequent water draw could be affected.

Reference [Figure 4-11](#) and [Figure 4-12](#).

1. Install the inner seal, the backup washer, the outer (larger) seal and retaining ring into the hydraulic seal support. Open ends of both seals are to face the flow tube.
2. Install the o-ring on the hydraulic seal support holding it in place with a small amount of lubricant.
3. Install the hydraulic seal support on the inlet flange by sliding it onto the actuator shaft. Apply a small amount of grease to the actuator shaft at the beveled edge to ensure the seals do not fold over. Align the support with the weep hole pointing down. A slight rotation of the support may be necessary to align the bolt pattern between the support and the inlet flange. Secure the support with the socket head screws.
4. Install the downstream flange of the hydraulic cylinder by sliding it onto the actuator shaft. Apply a small amount of grease to the actuator shaft at the beveled edge to ensure the seals do not fold over. Align the hydraulic ports in the flange with the hydraulic hoses and the stud holes with those in the hydraulic seal support.
5. Install the cushion on the actuator shaft with the chamfer facing the flow tube.
6. Install new seals on the actuator piston and install the piston to the actuator shaft. Use care not to damage the o-ring in the bore of the actuator piston with the shaft threads by threading it onto the actuator shaft.
7. Install the locking nut and tighten with an impact wrench. The locking nut should be tightened until the actuator piston is unable to turn.
8. Install the two (2) o-rings on the end of the hydraulic cylinder tube. Pay attention to the flat o-ring as it must be installed with the flat side against the shoulder on the end of the tube. Then install the round o-ring.
9. Install the hydraulic cylinder tube over the actuator piston. Use a smooth piece of plastic to compress the piston seal as necessary. Slide the tube up to within approximately 1" of the downstream flange. Be sure the o-rings are in place.
10. Install the hydraulic cylinder tie rods into the tee of the inlet flange. If the rods have longer threads on one end, install these ends in the tee.
11. Install the o-rings onto the upstream end of the hydraulic cylinder tube. These o-rings are installed in the same manner as in step 8.
12. Install the upstream flange of the hydraulic cylinder. Also install the bracing plate from the support bar if so equipped.

13. Install the four nuts on the hydraulic cylinder tie rods. Double check the o-rings on each end of the hydraulic cylinder tube to make sure they are in place. Tighten the nuts evenly to bring the hydraulic cylinder tube and flanges together. Torque to specifications listed in [Table 4-3](#).

**TIP** To ensure proper alignment of the hydraulic cylinder, use a level to verify the alignment with the flow tube.

14. Connect the nitrogen supply hose from the spring plenum and the hydraulic hoses to the hydraulic cylinder.
15. Install the operating handle on the nitrogen shut-off valve. Open the shut-off valve and check for and eliminate any leaks.
16. Once the prover is fully assembled, check the hydraulic reservoir for proper level. Turn on the power and start the hydraulic system motor. Check for and eliminate any hydraulic system leaks. Once all air is eliminated from the hydraulic system, turn off the motor and re-check the reservoir for proper level.

**Table 4-3 Hydraulic cylinder tie rod nut torque**

Prover Size	Torque Value
8"	25 ft lbs (34 Nm)
12" Mini	45 ft lbs (61 Nm)
12"	45 ft lbs (61 Nm)
18"	125 ft lbs (170 Nm)
24"	220 ft lbs (299 Nm)
34"	600 ft lbs (814 Nm)
40"	1,400 ft lbs (1900 Nm)

#### 4.5 Optical conversion kit

Compact provers purchased prior to June 1989 are designed with a 'shotgun' style optical assembly. These older provers may be retrofitted to accommodate the new 'plug style' optical assembly. Installation instructions are provided with the kit. Switch replacement on the new design has been simplified from the old design. Volume re-certification is no longer necessary when replacing a volume switch on the 'plug style' or the 'pin-and-socket' optical assemblies.

See [Section 4.6](#) for further information regarding switch replacement on the 'plug style' optical assembly.

See [Table 7-1](#) for part numbers of retrofit kits for these older provers.

Compact provers built from June 1989 to December 2000 have the 'pin-and-socket' optical assemblies. If an upgrade to the new 'plug style' optical assembly is desired, a new optical assembly will be required. See [Table 7-1](#) for these part numbers.

#### 4.6 Detector Switch Replacement

Reference [Figure 4-13](#), [Figure 4-14](#) and [Figure 4-15](#).

##### **IMPORTANT**

When using more than one intrinsically safe circuit, the rules and regulations for interconnection shall be duly observed. The Switch Pad location has been factory set and under normal conditions will not require adjustment.

[Figure 4-13](#) Detector switch removal #1

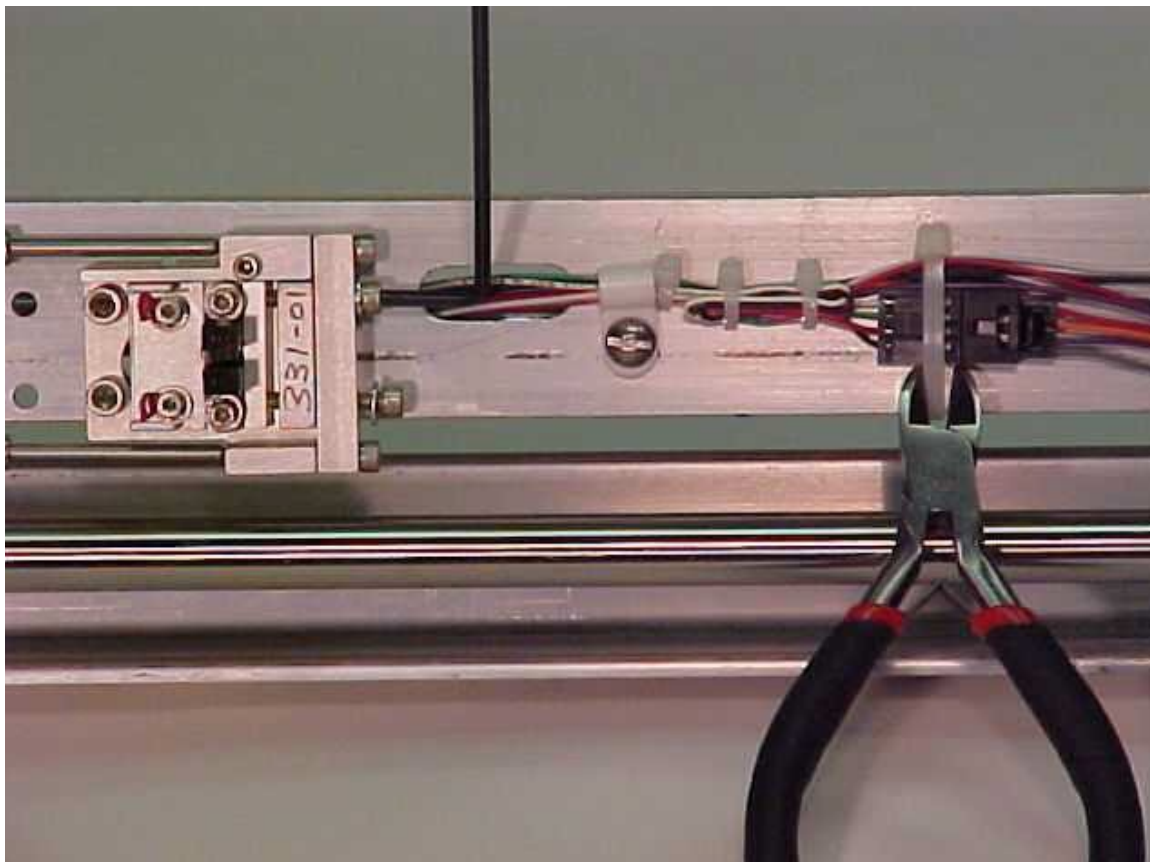

1. Disconnect electrical power to the unit.
2. Remove the support bracket at the outboard end of the detector shaft dust cover.
3. Remove the dust cover.
4. Carefully cut the wire ties holding the plug for the inoperative switch and remove any 'hoop style' anchors necessary. Disconnect the plug from the main harness by releasing the latch and separating the plug. (Figure 4-13)
5. Remove the mounting/adjustment screws holding the optical switch to the switch pad. (Figure 4-13)

Figure 4-14 Detector switch removal #2

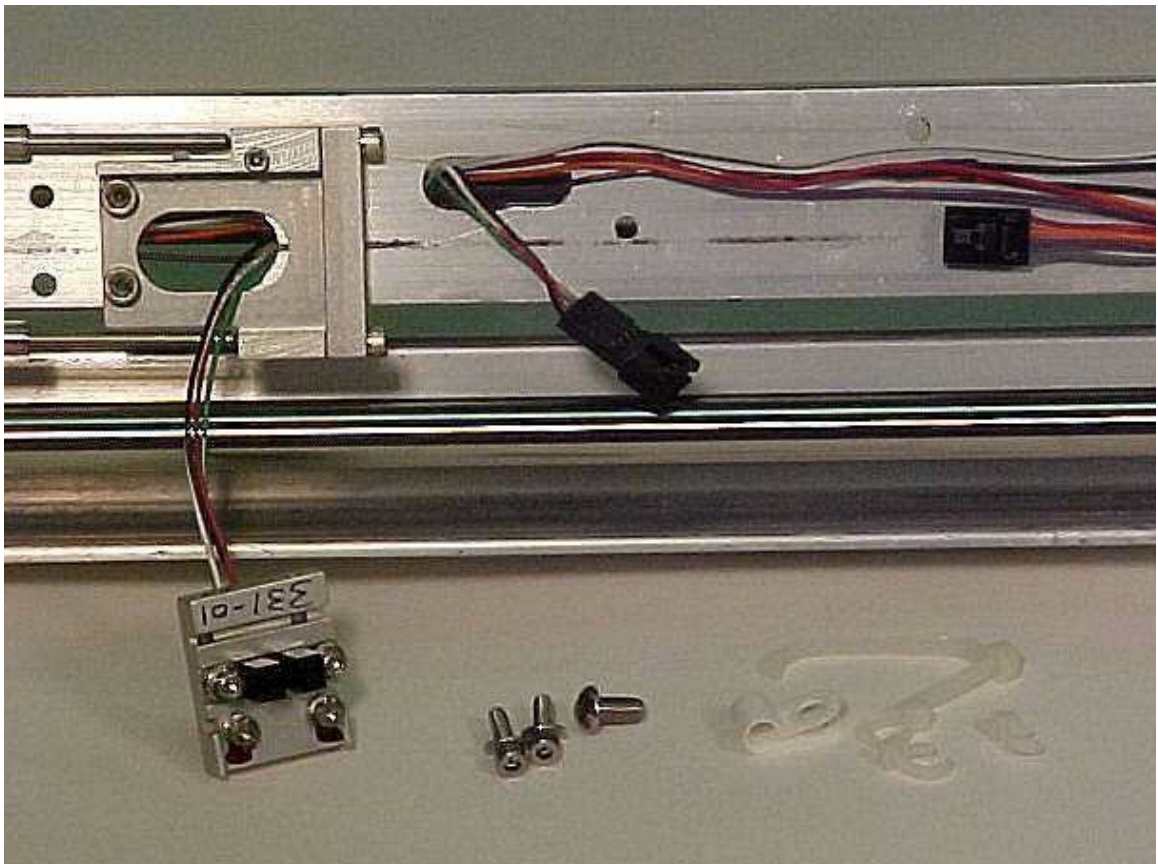

6. Carefully remove the switch assembly while feeding the switch plug through the frame. Be careful not to catch the plug on any other wires. (Figure 4-14)
7. Install the new switch. For a volume switch, ensure that the assembly base is positioned flat against the switch pad and square against the right end of the pad where the elongated holes are located.

8. Adjust the switch position so that the detector passes through the center of the switch. If necessary, loosen the bearing housing and slide it along the shaft while adjusting the switch position.

It may be necessary to pry the bearing housing free from the optical shaft by using a small screwdriver in the rear slot. Return the bearing housing to its original position and tighten all screws. (Figure 4-15)

Figure 4-15 Detector switch adjustment

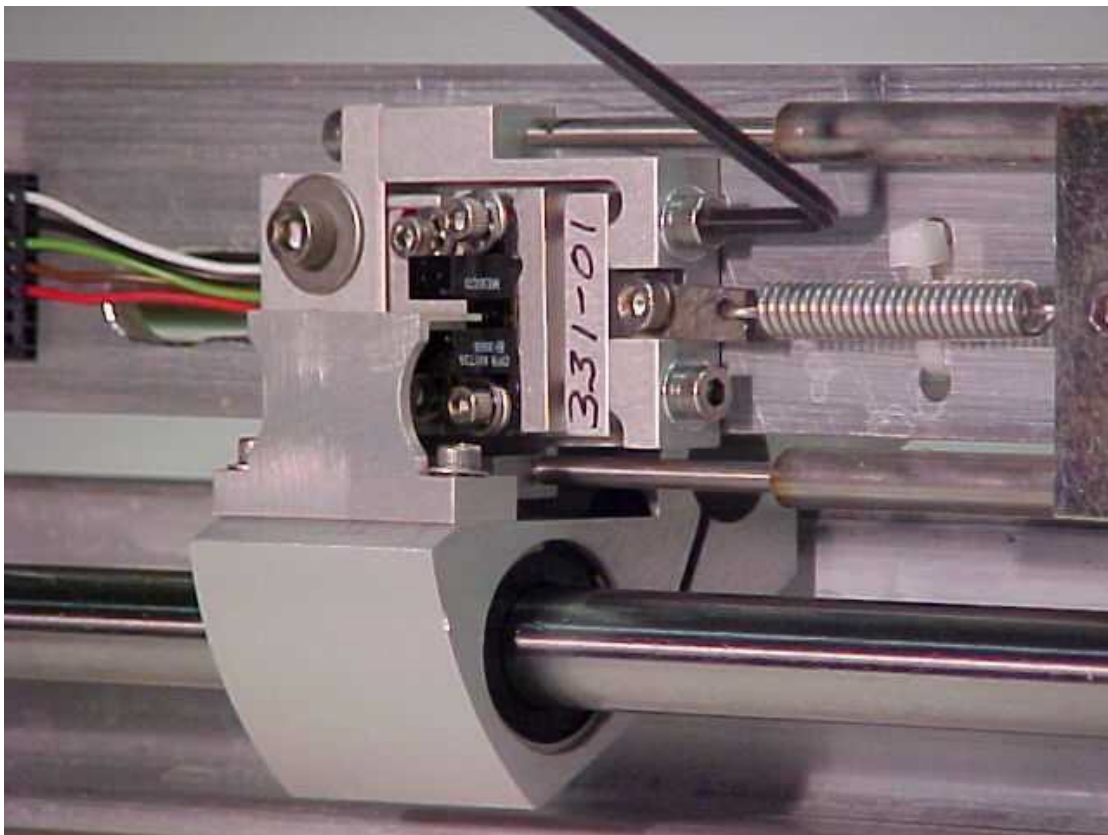

9. Plug the new switch into the main harness, feeding the plug back through the frame to the original location. Anchor the plug to the frame using a new wire tie and replace any "hoop-style" wire anchors.
10. Verify wires will not interfere with the detector movement. Adjust and/or anchor as necessary.
11. Replace the dust cover and support bracket.
12. Upon completion of volume certification see [Section 2.4](#).

If the switch replacement procedure has been performed correctly, the replacement switch will be within 0.001 inches (.0254 mm) from the original switch position. The formula for cylinder volume can be used to determine the degree of change in the water draw volume.

Example for a 12" prover:

Water draw volume change for 0.001 inch of switch movement =

$$\pi (d/2) (0.001) = \pi (12.25/2) (0.001) = 0.1178 \text{ in}^3$$

Since 15 gallons = 3465 in<sup>3</sup> :

$$\text{The percent change} = 0.1178/3465(100) = 0.0034\%$$

This percent change in the water draw volume is well within the 0.02% allowed. Similar changes can be expected in the other size provers. See Table 4-4 below.

**Table 4-4 Volumetric percent change for compact provers**

Prover Size	Nominal prover base volume	Flow tube I.D.	Base volume from nominal	Percent change
8"	5 gal (20 l)	8.250" (20.955 cm)	1,155 in <sup>3</sup> (20000 cm <sup>3</sup> )	0.0046% (.0044%)
12" Mini	10 gal (40 l)	12.250" (31.115 cm)	2,310 in <sup>3</sup> (40000 cm <sup>3</sup> )	0.0051% (.0048%)
12"	15 gal (60 l)	12.250" (31.115 cm)	3,465 in <sup>3</sup> (60000 cm <sup>3</sup> )	0.0034% (.0032%)
18"	30 gal (120 l)	17.500" (44.450 cm)	6,930 in <sup>3</sup> (120000 cm <sup>3</sup> )	0.0034% (.0032%)
24"	65 gal (250 l)	25.500" (64.770 cm)	15,015 in <sup>3</sup> (250000 cm <sup>3</sup> )	0.0034% (.0033%)
34"	100 gal (400 l)	34.00" (86.360 cm)	23,100 in <sup>3</sup> (400000 cm <sup>3</sup> )	0.0039% (.0037%)
40"	170 gal (650 l)	40.00" (101.60 cm)	39,270 in <sup>3</sup> (650000 cm <sup>3</sup> )	0.0032% (.0032%)

# Section 5: Troubleshooting

## 5.1 General

Should the electrical system of the compact prover require repair, the following two sections contain solutions and information to help solve problems that may be encountered. If these steps and information do not help solve the operational problem, contact a Brodie representative for assistance. [Figure 5-2](#) and [Figure 5-3](#) are provided as typical wiring diagrams for reference. Special build electrical systems will have an electrical diagram supplied with the documentation package.

### DANGER

#### HIGH VOLTAGE HAZARD

**Wear appropriate personal protective equipment and follow all safety instructions when working with high voltage electrical circuits.**

Failure to do so will result in serious injury or death.

## 5.2 Interface Signals

Reference [Figure 2-3](#) and [Figure 2-4](#).

### IMPORTANT

Do not handle electronic-sensitive equipment without an ESD grounding wrist-strap. Failure to use an anti-static grounding device could cause damage to the compact prover electronics and render them inoperable.

The compact prover interface board control circuits communicate with the operating computer using digital signals. These signals are the RUN command input, the UPSTREAM output, and the volume DETECTOR output.

**RUN command:** The run command signal is held high (approx. 12VDC) by the interface board and must be pulled low (less than 2VDC) by the operating computer to launch the measurement piston. This signal is present between pins 2(-) and 5(+) of J-2.

**UPSTREAM output:** The upstream signal is designed as an open collector (30VDC, 400mA max) output. This signal must be pulled high by the operating computer. It is pulled low by the interface board whenever the flag is within the upstream switch. This signal is present between pins 2(-) and 6(+) of J-2.

**DETECTOR output:** The detector signal is designed as an open collector (30VDC, 400mA max) output. This signal must be pulled high by the operating computer, and is pulled low by the interface board whenever the flag is within either of the optic volume switches. This signal is present between pins 2(-) and 7(+) of J-2.

Figure 5-1 is a timing diagram that shows the interface signal operation that the operating computer will see coming from the compact prover during a proving cycle. The diagram positions are explained below.

- t1** - Computer sends RUN signal low, hydraulics go into bypass, poppet closes and measurement piston and flag start downstream.
- t2** - Flag clears upstream (stand-by) switch; upstream signal goes high.
- t3** - Flag enters the first volume switch sending detector signal low. As flag exits switch, signal goes high.
- t4** - Flag enters the second volume switch sending detector signal low. As flag exits switch, signal goes high.
- t5** - Computer sends RUN signal high, hydraulics are activated, poppet opens and measurement piston starts upstream.
- t6** - Flag enters the second volume switch sending detector signal low. As flag exits switch, signal goes high. Computer ignores pulses during return stroke.
- t7** - Flag enters the first volume switch sending detector signal low. As flag exits switch, signal goes high. Computer ignores pulses during return stroke.
- t8** - Flag enters upstream (stand-by) switch, upstream signal goes low. Compact prover remains in this condition until RUN command is received from computer.

Figure 5-1 Prover signal timing

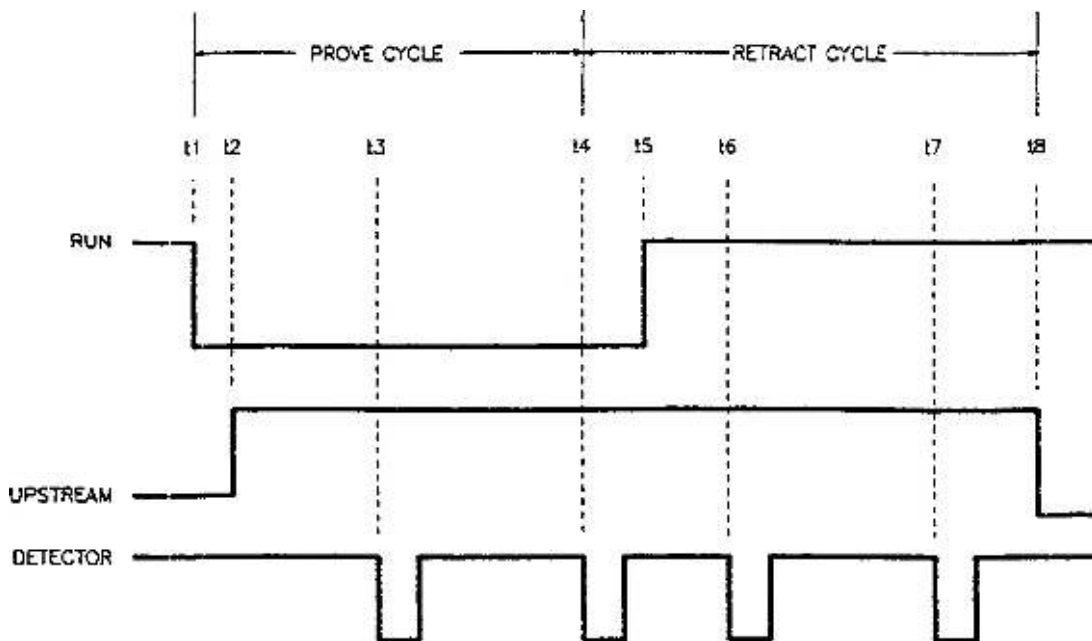

### 5.3 Measurement Piston Movement

**Piston does not move upstream:** (No hydraulic pressure)

1. Check to be sure the hydraulic system motor is running. If so, check the hydraulic control valve operation by disconnecting the AC voltage at the junction box adjacent to the valve. If the Piston fails to return, the hydraulic control valve is stuck open and is in need of repair or the hydraulic pump is defective.
2. If the piston returned in step 1, reconnect the AC voltage to the control valve and then unplug the DC power to the control relay at connection J-4 on the prover interface board. If the piston does not return, the control valve relay is defective.
3. If the piston returned in step 2, check the voltage between pins 2 (-) and 5 (+) of connection J-2 on the interface board. If this voltage is low (less than 2V), the operating computer is responsible. If this voltage is high (more than 8V), the interface board is defective.
4. If the operating computer is found responsible, check the red LED on the prover interface board. If this LED is illuminated, and the flag is not in a volume switch, this indicates a problem in the volume switch circuit. Make a jumper connection between pins 2 and 3 of connection J-1 on the prover interface board. If connecting this jumper turns the LED off, check the optical barriers for approximately 230 ohms resistance (for fuse barriers, 250 ohms for non-fused) across connection terminals 1 and 3. If no resistance is detected, replace the fuse of the barrier in question (or replace the non- fused barrier) and check the grounding system integrity.

If the barrier resistance is found acceptable, the cause will be in the optical assembly wiring or volume switches.

**Piston does not move downstream:** (Hydraulic pressure will not release)

1. Apply the correct AC voltage for the solenoid at the connection to the hydraulic control valve. If the control valve fails to open (piston does not launch), the solenoid may be defective or the valve itself is stuck closed.
2. If the control valve opened in step 1, disconnect J-4 on the prover interface card and apply a voltage of 12VDC to the control side of the relay. If the control valve does not open, the control valve relay is defective.
3. If the control valve opened in step 2, reconnect J-4 and jump a connection between pins 2 and 5 of J-2 on the prover interface board (control voltage must be present at pin 4 (+) and 2 (-) of J-2).

If the control valve does not open (piston does not launch), the prover interface board is defective.

4. If the control valve opened in step 3, the operating computer is not sending the run command (dropping to 0V) to pin 5 of J-2. One possible cause for this problem may be that the operating computer is not receiving the upstream signal from the optical assembly. The voltage between pins 6 (+) and 2 (-) of J-2 on the prover interface

board should be low (less than 2V) and the green LED illuminated (if equipped) with the piston in the full upstream position. Be sure to check the safety barriers for proper resistance. If the barrier resistance is acceptable, the cause may be in the optical assembly wiring or upstream switch.

Figure 5-2 Prover wiring diagram (single phase power)

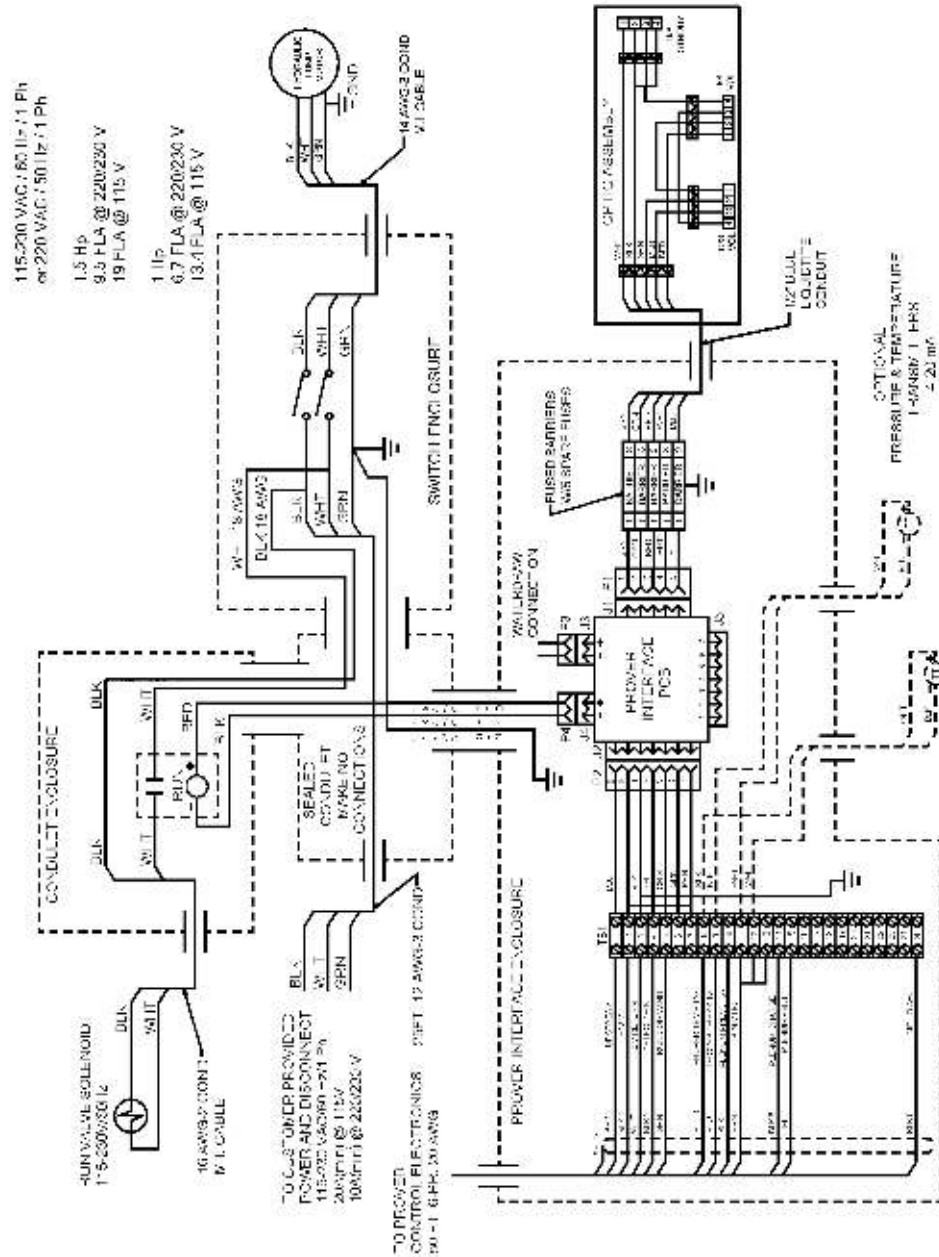

Figure 5-3 Prover wiring diagram (three phase power)

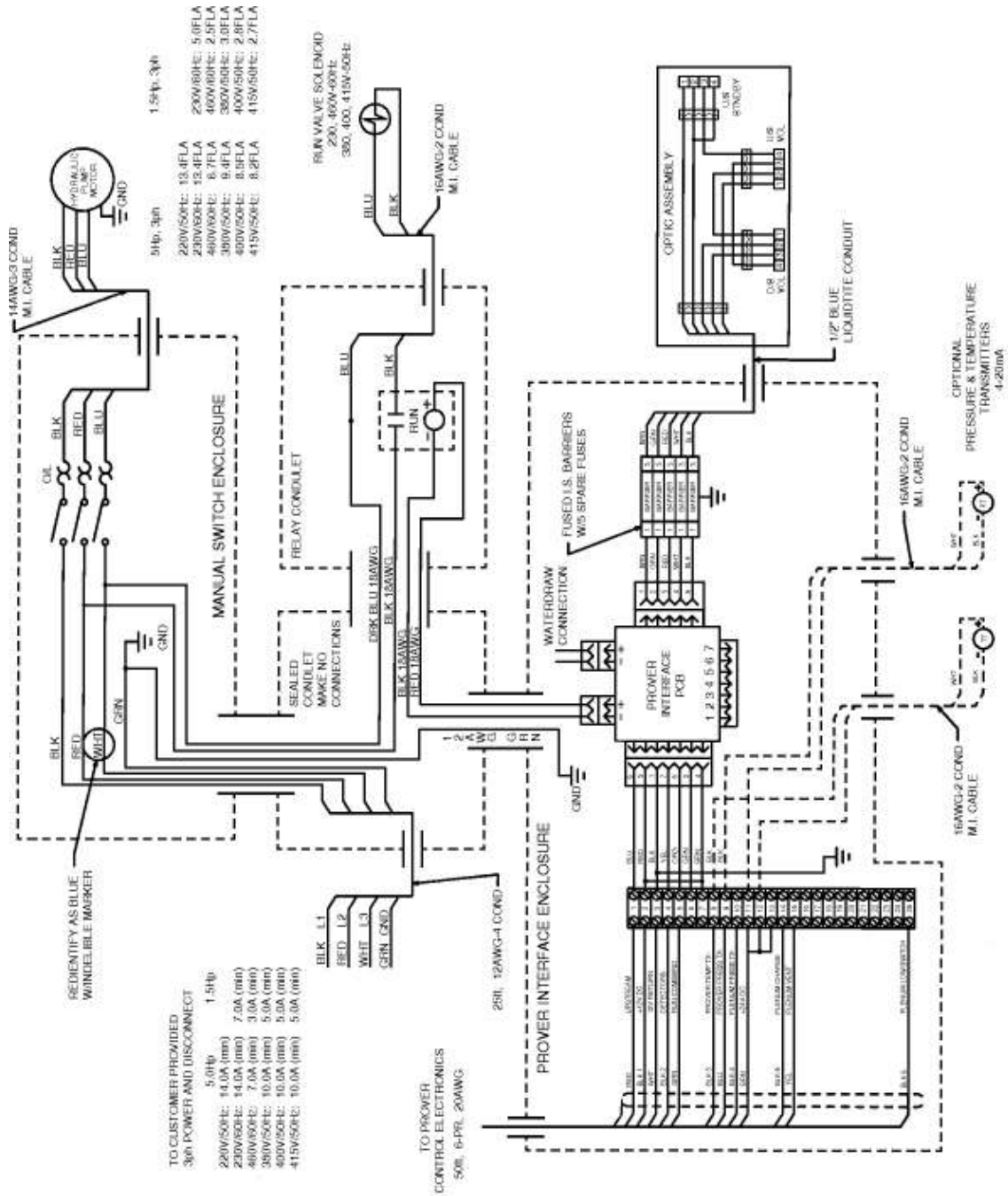

Figure 5-4 Prover wiring diagram (ATEX and IECEx internal)

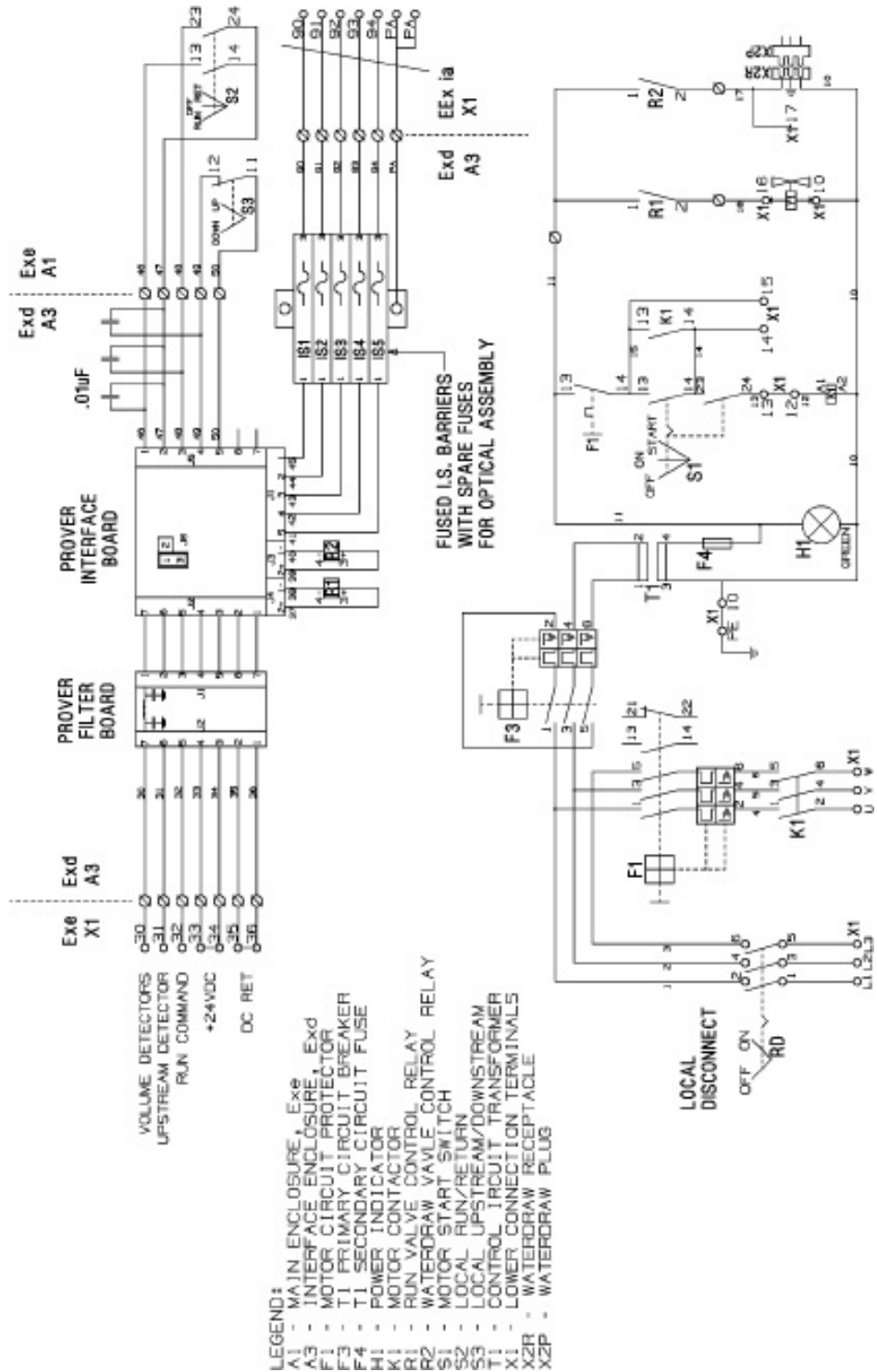
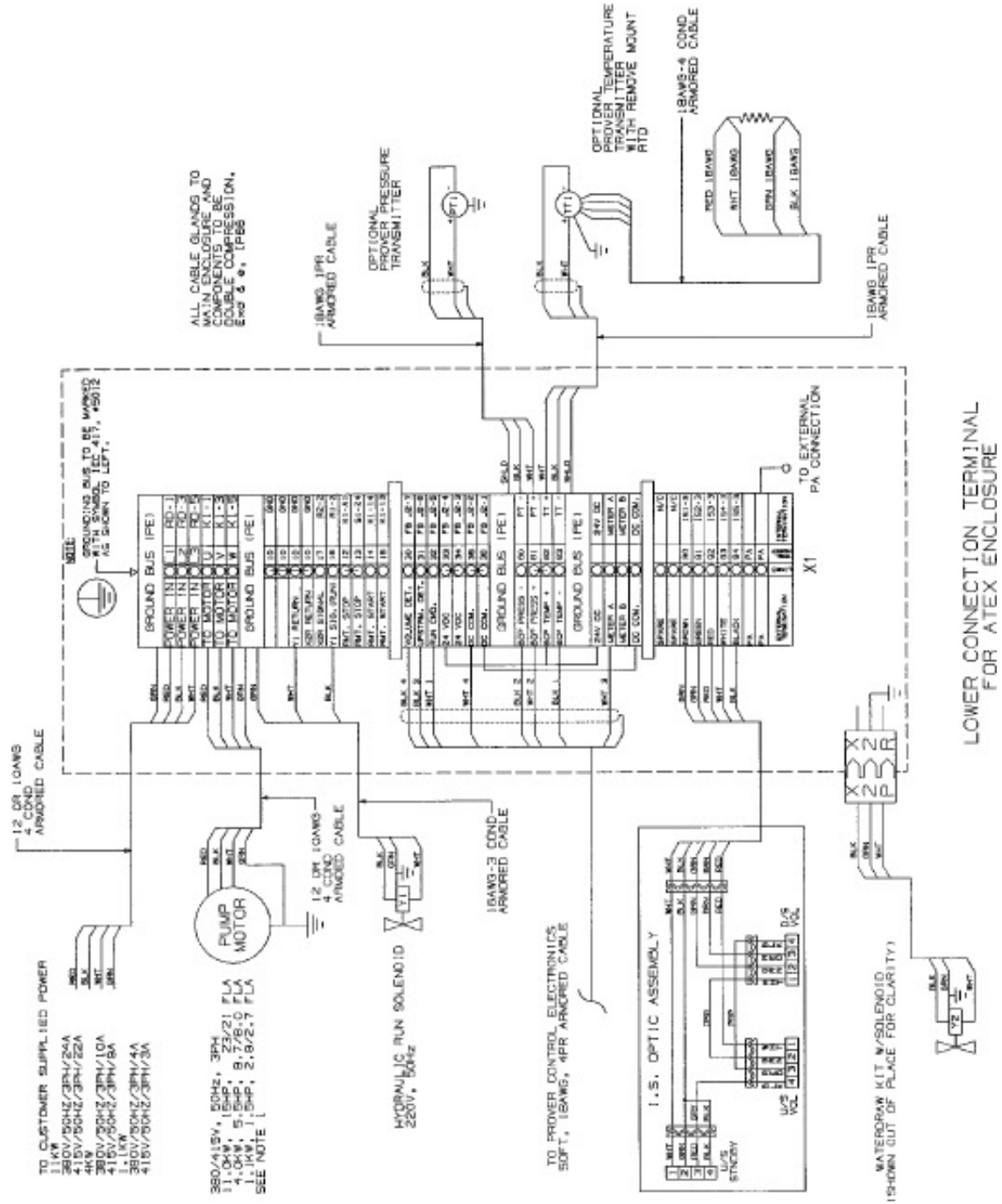

Figure 5-5 Prover wiring diagram (ATEX and IECEx external)



## 5.4 The auto plenum adjust panel

Compact prover plenum adjustment panels can have either AC or DC power solenoids. Sometimes these solenoids will not work correctly or at all. The problem typically lies in the control circuits for the solenoid relays. These circuits for the relays are DC powered directly from the operating computer. The control coil of these relays must be wired to match the computer output configuration.

### Signal determination:

Prover flow computers use one of the following output signal types for charge and vent:

- Driving current
- Sinking current

### NOTE

- Measure the signal voltage levels at TB1 with a typical DMM (Digital Multi Meter) set for DC voltage in the prover interface closure or at the relay itself. TB1 is the most common place to take these measurements because all conductors and signals should be present.
- If the signal does not change state (with high or low voltage) at TB1 or at the relay, trace back to the operating computer for accurate measurements. There should be no loose or corroded connections.

### Driving current signal

The operating computer will output a +24V DC signal when active and the DC negative will be common to both relays. When not active, the signal will go to 0V DC.

- Use a negative reference (-) for the DMM at a convenient point where the computer and prover DC negative is common between two.
- If necessary, disconnect the signal conductor at the computer to take accurate measurements.

### Sinking current signal

The operating computer will output a DC negative signal when active and the +24V DC will be common to both relays. When not active, the signal will go to +24V DC.

- Use a positive reference (+) for the DMM at the main DC power source for the system or at TB1.
- If necessary, disconnect the signal conductor at the computer to take accurate measurements.

**Correction procedure:**

Determine which type of computer output is being used and compared this to the wiring at the relays.

1. If necessary, refer to the prover's wiring diagram.
2. If +24V DC is common to both relays and the negative (-) from the coil of each relay goes back to TB1, they are wired for sinking current.
3. If the DC negative (-) is common to both relays, and the positive (+) wire from the coil of each relay goes back to TB1, they are wired for driving current.
4. Correct the wiring as needed for the type of computer signal being used.
5. See [Figure 5-6](#) and [Figure 5-7](#) for simplified diagrams.
6. Restore power and test signals again for correct operation.
7. If the solenoids begin to work as desired but the proving computer still automatically aborts the proving sequence, be certain the plenum "time out" (the time set within the computer's configuration to charge/vent the plenum) is long enough to fill or vent the plenum. Due to the small orifice of the solenoid valves, it can take some time to adjust the plenum pressure to the needed value. Manual charging or venting of the plenum may be necessary.

Figure 5-6 DC powered solenoids

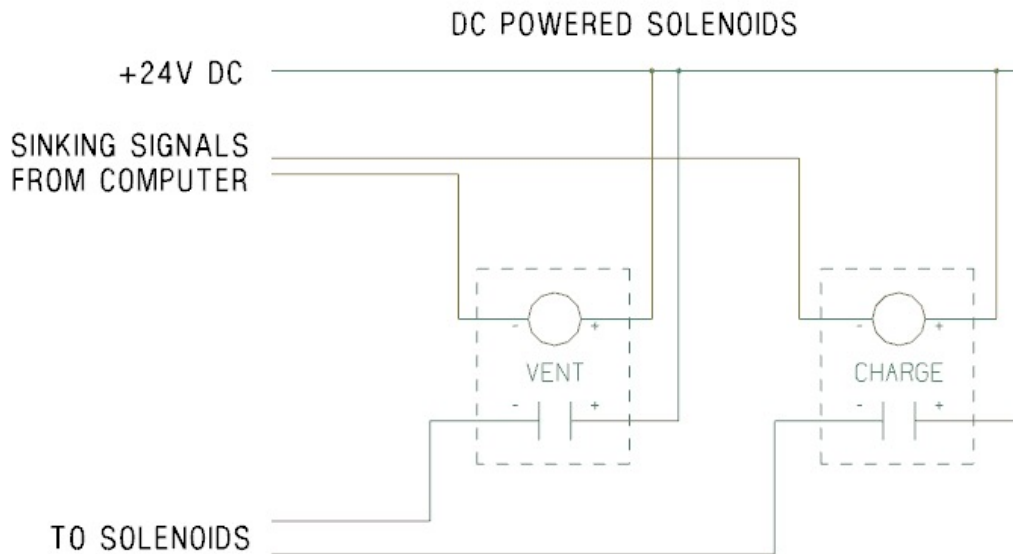
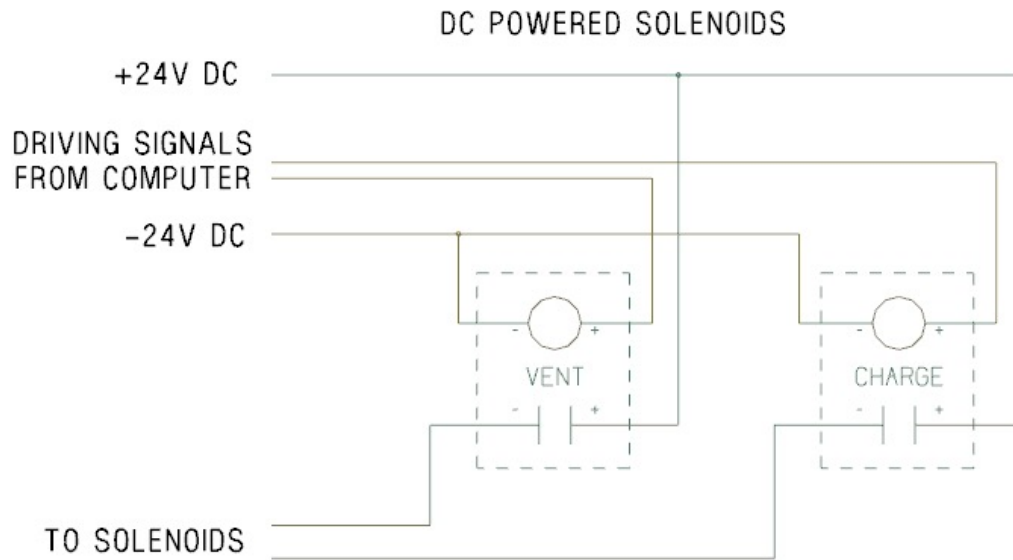
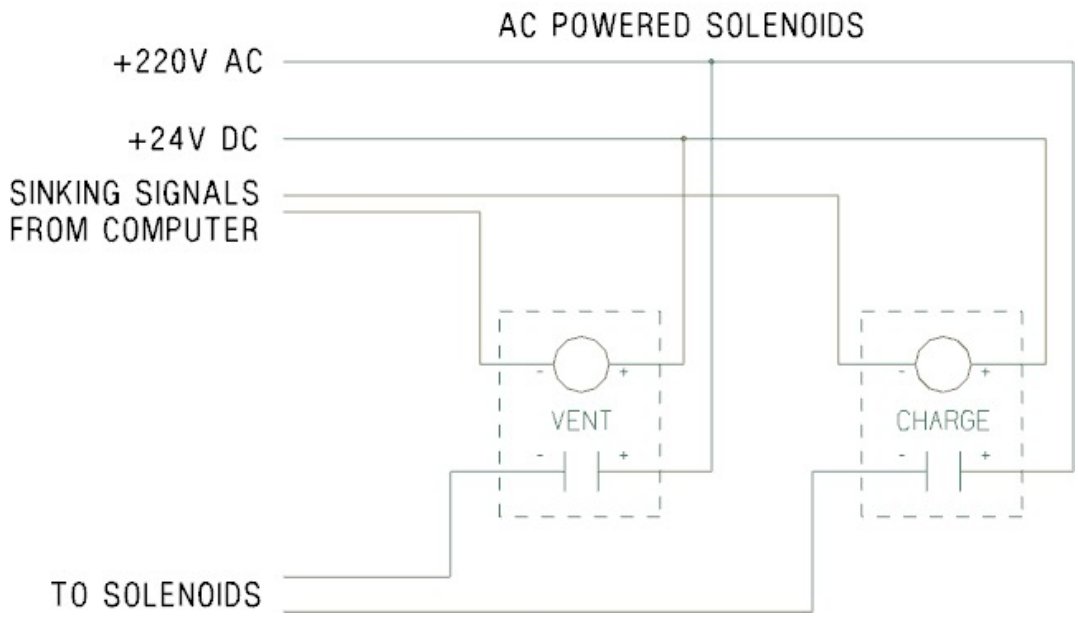
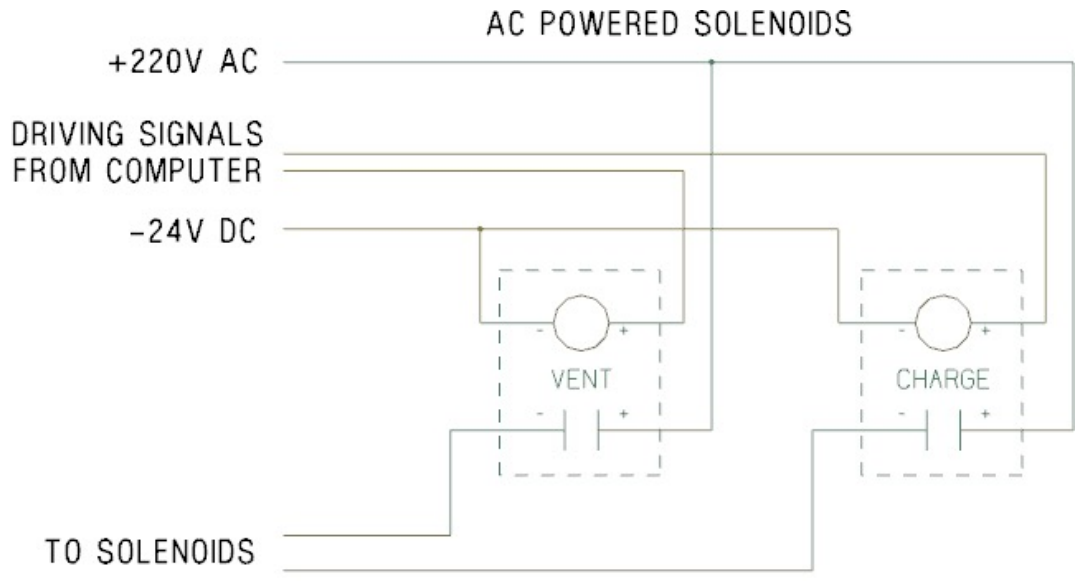

Figure 5-7 AC powered solenoids



## Section 6: Special Tools and Equipment

### 6.1 Tool List

The following list of parts will aid the qualified technician in repair of the compact prover:

1. Heavy Duty non-marking Strap Wrench, McMaster-Carr part number: 5349A12 McMaster-Carr

2. Torque Wrenches

Torque wrenches are necessary for assembly and repair of the compact prover. See [Tables 4-2 and 4-3](#) for specified torque ratings of the compact prover Tie Rods and Hydraulic Cylinders. See [Table 4-1](#) for torque requirements for poppet.

3. Standard Allen wrenches, box-end wrenches and other common tools may also be used for repair of the compact prover. Refer to [Table 6-1](#).

Table 6-1 Tool size requirement

Prover Size	ANSI	Tie rod nut socket size	Hydraulic tie rod nut socket	Hydraulic cylinder piston nut socket size	Allen Screw for Hydraulic Gland	Allen Screw for Optical Gland
8"	150#	1-5/8"	9/16"	3/4"	5/16"	1/2" & 3/8"
	300#	1-5/8"				
	600#	1-5/8"				
12" mini	150#	1-5/8"	3/4"	15/16"	1/2"	1/2" & 3/8"
	300#	1-5/8"				
	600#	2-3/16"				
12"	150#	1-5/8"	3/4"	15/16"	1/2"	1/2" & 3/8"
	300#	1-5/8"				
	600#	2-3/16"				
18"	150#	2"	1-5/16"	1-7/16"	5/8"	1/2" & 3/8"
	300#	2"				
	600#	2-3/8"				
24"	150#	2"	1-7/16"	2-3/16"	5/8"	1/2" & 3/8"
	300#	2-3/8"				
	600#	2-15/16"				
34"	150/300#	3-1/8"	2-3/16"	n/a	3/4"	1/2"
40"	150/300#	3-1/8"			3/8"	3/8" & 5/8"

Table 6-2 Torque values for pipe flange stud/nut sets

Prover Size	Nut Size	Torque Requirement					
		ANSI 150		ANSI 300		ANSI 600	
		Ft-lbs	Nm	Ft-lbs	Nm	Ft-lbs	Nm
8"	5/8"	75	102	65	88	65	88
12" mini	5/8"	95	129				
	3/4"			120	163		
	7/8"					215	292
12"	3/4"	165	224	135	183		
	1"					295	400
18"	3/4"	190	258				
	7/8"			220	299		
	1-1/8"					455	618
24"	7/8"	280	380				
	1-1/8"			390	529		
	1-1/4"					555	753
34"	1"	400	542				
	1-1/4"			545	740	n/a	n/a
40"	1-1/4"			620	841	n/a	n/a

# Section 7: Parts List

## 7.1 General

This section contains those parts required to properly maintain and service a standard compact prover. Reference those drawings applicable to the specific prover size and configuration. See [Figure 7-1](#), [Figure 7-2](#) and [Figure 7-3](#).

## 7.2 Replacement Parts List

[Table 7-1](#) is a list of the parts that may require replacement in the Compact Prover. Parts listed as 'N/S', are not shown in the figures. A part number designated as 'N/A' is not applicable. A part number designated as 'C/F' will require factory consultation.

If a part is necessary for repair of the Compact Prover and is not listed in [Table 7-1](#), contact a Brodie representative or the factory for assistance. The following information will be needed to properly identify the part(s) needed for repair:

- Compact prover serial number
- Compact prover model number
- Compact prover size (i.e. 8", 12"Mini, 12", 18", 24", 34" or 40")
- Part description and number (if available)
- Quantity required

The following companies are quality manufacturers of the components parts used in construction of the compact prover:

Brodie® Compact Prover™	Brodie International, LLC
Kalrez ®	E.I. du Pont de Nemours and Company
Teflon®	E.I. du Pont de Nemours and Company
Viton®	E.I. du Pont de Nemours and Company
Neoprene™	E.I. du Pont de Nemours and Company

Viton® is a registered trademark of E.I. du Pont de Nemours and Company.

Table 7-1 Parts list

Item	Description	Qty	8"	12 Mini"	12"	18"	24"	34"	40"
<b>1</b>	Complete seal kit*1								
	Buna-N		SK08	SK12	SK12	SK18	SK24-07	SK34	C/F
	pre 2006	1					SK24		
	FKM		SK08-022	SK12-022	SK12-022	SK18-022	SK24-022- 07	SK34-022	SK40-022
	pre 2006	1					SK24-022		
	PFKM		SK08-075	SK12-075	SK12-075	SK18-075	SK24-075- 07	SK34-075	C/F
	pre 2006	1					SK24-075		
	CR		C/F	C/F	C/F	C/F	C/F	C/F	C/F
	pre 2006	1					C/F		
	FKM/PFKM		C/F	C/F	C/F	C/F	C/F	C/F	C/F
	pre 2006	1					C/F		
	FKM for crude oil		SK08-222	SK12-222	SK12-222	SK18-222	SK24-222	SK34-222	C/F
<b>2</b>	Cup seal	1	157367	157367	157367	157367	1500127	1500127	156958
	FKM for crude oil		157367-022	157367-022	157367-022	157367-022	1500127-022	1500127-022	C/F
	pre 2006	1					157367		
<b>3</b>	Cup seal	1	157364	157364	157364	157364	1500126	1500126	156957
	pre 2006	1					157364		
<b>4</b>	Cup seal	1	157364	157364	157364	157364	1500127	1500127	156957
	pre 2006						157364		
<b>5</b>	Cup seal	1	157385	157362	157362	157372	157392	1500134	156959
	FKM for crude oil		157385-022	157362-022	157362-022	157372-022	157392-022	1500134-022	C/F
<b>6</b>	Cup seal	1	157384	157363	157363	157374	157338	1500135	156961
<b>8</b>	Poppet O-ring	1	157387-022	157337-022	157337-022	157371-022	157395-022	1500136-022	159605-022
<b>9</b>	Front piston rider	1	911-08-017-00	911-12-017-00	911-12-017-00	911-18-018-00	911-24-018-00	911-34-018-00	911-40-018-00
<b>10</b>	Rear piston rider	1	911-08-017-00	911-12-018-00	911-12-018-00	911-18-018-00	911-24-018-00	911-34-018-00	911-40-018-00
<b>11</b>	Piston cup seal	2	157388	157365	157365	157373	157393	1500137	158993
<b>12</b>	Hydraulic O-ring	1	157386-022	157084-022	157084-022	157011-022	157081-022	1500131	159602-022

Table 7-1 Parts list

Item	Description	Qty	8"	12 Mini"	12"	18"	24"	34"	40"
13	Optical O-ring	1	157360-022	157360-022	157360-022	157360-022	1500125	1500125	159600-022
	pre 2006	1					157360-022		
14	Flowtube O-ring	2	157383-022	157336-022	157336-022	157370-022	157394-022	1500124-022	158919-022
15	Seal backup washer	1	911-12-027-00	911-12-027-00	911-12-027-00	911-12-027-00	911-34-027-00	911-34-027-00	911-40-025-00
	pre 2006	1					911-12-027-00		
16	Op. Retaining ring	1	156551	156551	156551	156551	1500130	1500130	156571
	pre 2006	1					156551		
17	Small op. seal washer	1	911-12-025-00	911-12-025-00	911-12-025-00	911-12-025-00	911-34-025-01	911-34-025-01	911-40-025-00
	pre 2006	1					911-12-025-00		
18	Seal backup washer	1	911-12-024-00	911-12-024-00	911-12-024-00	911-12-024-00	N/A	N/A	911-40-027-00
	pre 2006						N/A	N/A	
	For crude oil		911-12-024-02	911-12-024-02	911-12-024-02	911-12-024-02	N/A	N/A	C/F
	pre 2006	1					911-12-024-02		
19	Op. retaining ring	1	156549	156549	156549	156549	156565	1500128	156570
20	Seal backup washer	1	911-08-029-00	911-12-029-01	911-12-029-01	911-18-029-00	911-24-029-00	911-34-029-00	911-40-029-00
	For crude oil		911-08-029-02	911-12-029-02	911-12-029-02	911-18-029-02	911-24-029-02	911-34-029-02	C/F
21	Hyd. retaining ring	1	156561	156558	156558	156552	156563	1500133	156572
22	Hydraulic system motor (V/ Hz/ph)								
	115/60/1 NEC	1	1500709	1500709	1500731	1500731 (2)	N/A	N/A	N/A
	230/60/1 NEC	1	1500709	1500709	1500708	1500708 (2)	N/A	N/A	N/A
	230/460/60/3 NEC	1	C/F	C/F	1500707	1500711 (1)	1500711	1500718	1500719
	220/50/1 NEC	1	1500710	1500710	1500706	1500706 (2)	N/A	N/A	N/A
	220/440/50/3 NEC	1	C/F	C/F	C/F	1500712 (1)	1500712	C/F	C/F
	380/50/3 ATEX and IECEx	1	1500267	1500267	1500267	1500269 (1)	1500269	1500071	C/F
	415/50/3 ATEX and IECEx	1	1500266	1500266	1500266	1500268 (1)	1500268	1500272	C/F

Table 7-1 Parts list

Item	Description	Qty	8"	12 Mini"	12"	18"	24"	34"	40"
23	Hydraulic pump	1	157925	157925	157925	157925 (2) 157983 (1)	157983	158916	158916
24	Hyd. control valve solenoid (V/Hz)								
	110/60 NEC	1	158263	158263	158263	1500673	1500673	1500673	1500673
	230/60 NEC	1	158264	158264	158264	1500274	1500274	1500274	1500274
	220/50 NEC	1	158266	158266	158266	1500627	1500627	1500627	1500627
	380/50 NEC	1	1500639	1500639	1500639	1500639	1500639	1500639	1500639
	220/50 ATEX and IECEX	1	1500113	1500113	1500113	1500113	1500113	1500113	1500113
25	Optical barriers	1-5	159944	159944	159944	159944	159944	159944	159944
	Replacement fuses	5pk	159946	159946	159946	159946	159946	159946	159946
26	Interface board 12/24 V	1	911-12-072-03	911-12-072-03	911-12-072-03	911-12-072-03	911-12-072-03	911-12-072-03	911-12-072-03
27	Control valve relay								
	<250V, NEC	1	158220	158220	158220	158220	158220	158220	158220
	>250V, NEC	1	158721	158721	158721	158721	158721	158721	158721
	ATEX and IECEX	1	158220	158220	158220	158220	158220	158220	158220
28	Motor start switch								
	Single phase	1	158807	158807	158807	158807 (2)	N/A	N/A	N/A
	Three phase	1	C/F	C/F	1500463	1500463	1500463	C/F	C/F
	ATEX and IECEX		C/F	C/F	C/F	C/F	C/F	C/F	C/F
29	Control cable								
	NEC	50ft	1500237	1500237	1500237	1500237	1500237	1500237	1500237
	ATEX and IECEX option 1	50ft	1500278	1500278	1500278	1500278	1500278	1500278	1500278
<b>33</b>	Power cable								
	Single phase NEC	25ft	HW-968D-036	HW-968D-036	HW-968D-036	HW-968D-036	N/A	N/A	N/A
	Three phase NEC	25ft	C/F	C/F	HW-968D-038	HW-968D-038	HW-968D-038	1500386	1500386
	Three phase ATEX and IECEX	25ft	C/F	C/F	1500275	1500275	1500275	C/F	C/F
	Hydraulic cylinder seal kit	1	159409	158260	158260	158273	159410	1500123	1500123
<b>35</b>	Seal supporting bushing	1	158647	911-12-009-01	911-12-009-01	911-18-009-00	911-24-009-00	911-34-009-00	C/F

Table 7-1 Parts list

Item	Description	Qty	8"	12 Mini"	12"	18"	24"	34"	40"
<b>36</b>	Retaining ring	1	156561	156559	156559	156553	156452	1500133	C/F
<b>37</b>	Seal Backup washer	1	N/A	N/A	N/A	N/A	911-24-029-01	911-34-029-01	911-40-029-01
<b>38</b>	Seal backup washer	1	N/A	N/A	N/A	N/A	911-34-025-00	911-34-025-00	N/A
	Crude	1	N/A	N/A	N/A	N/A	911-34-025-02	911-34-025-02	N/A
<b>39</b>	Detector shaft bushing	2	911-12-010-00	911-12-010-00	911-12-010-00	911-12-010-00	N/A	N/A	155108
<b>40</b>	Retaining ring	2	156554	156554	156554	156554	N/A	N/A	156569
<b>41</b>	Large detector shaft bushing	1	N/A	N/A	N/A	N/A	911-24-010-03	911-34-010-01	N/A
	pre 2006						911-24-010-01		
<b>42</b>	Retaining ring	1	N/A	N/A	N/A	N/A	1500128	1500128	N/A
	pre 2006						156565		
<b>43</b>	Small detector shaft bushing	1	N/A	1N/A	N/A	N/A	911-24-010-02	911-34-010-00	N/A
	pre 2006						911-24-010-00		
<b>44</b>	Retaining ring	1	N/A	N/A	N/A	N/A	156473	156473	N/A
	pre 2006						156554		
<b>45</b>	Piston bearing sleeve	1	158645	155103	155103		158694	911-34-087-00	C/F
<b>46</b>	Retaining plug	2	156549	156557	156557	156555	156564	1500133	C/F
<b>N/S</b>	Optical retrofit kit	2							
	Gallons	1	911-08-384-01M	921-12-384-01M	921-12-384-01M	911-18-384-01M	911-24-384-01M	N/A	N/A
	Liters	1	911-08-384-02M	921-12-384-02M	921-12-384-02M	911-18-384-02M	911-24-384-02M	N/A	N/A
<b>N/S</b>	Optical Assembly								
	Gallons pre 2006	1	911-08-325-11	921-12-325-11	921-12-325-11	911-18-325-11	911-24-325-11	911-34-325-11	911-40-325-11
	Gallons						911-24-325-12		
	Liters pre 2006	1	911-08-325-16	921-12-325-16	921-12-325-16	911-18-325-16	911-24-325-16	911-34-325-16	911-40-325-16
	Liters						911-24-325-17		

Table 7-1 Parts list

Item	Description	Qty	8"	12 Mini"	12"	18"	24"	34"	40"
<b>N/S</b>	Waterdraw kit								
	115V, °F, NEC	1	911-12-372-01	911-12-372-01	911-12-372-01	911-18-372-01	911-18-372-01	911-18-372-01	C/F
	115V, °C, NEC	1	911-12-372-51	911-12-372-51	911-12-372-51	911-18-372-51	911-18-372-51	911-18-372-51	C/F
	230V, °F, NEC	1	911-12-372-02	911-12-372-02	911-12-372-02	911-18-372-02	911-18-372-02	911-18-372-02	C/F
	230V, °C, NEC	1	911-12-372-52	911-12-372-52	911-12-372-52	911-18-372-52	911-18-372-52	911-18-372-52	C/F
	220V, °F, ATEX and IECEx	1	911-12-372-03	911-12-372-03	911-12-372-03	911-18-372-03	911-18-372-03	911-18-372-03	C/F
	220V, °C, ATEX and IECEx	1	911-12-372-53	911-12-372-53	911-12-372-53	911-18-372-53	911-18-372-53	911-18-372-53	C/F
<b>N/S</b>	Leak detector kit	1	911-12-360-00	911-12-360-00	911-12-360-00	911-12-360-00	911-12-360-00	911-12-360-00	911-12-360-00

Figure 7-1 Spare parts diagram (flow tube)

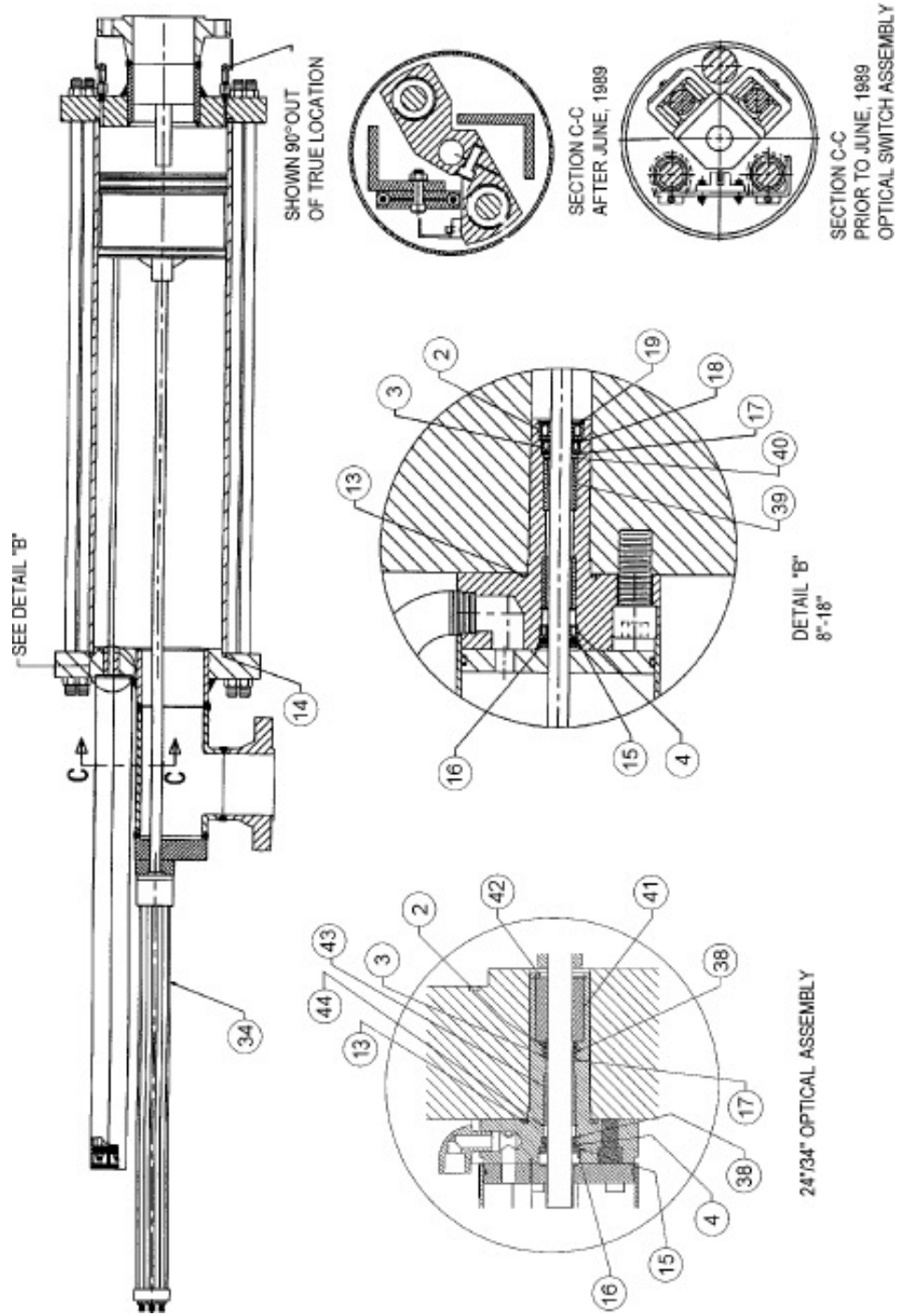

Figure 7-2 Spare parts diagram (Flow tube) (continued)

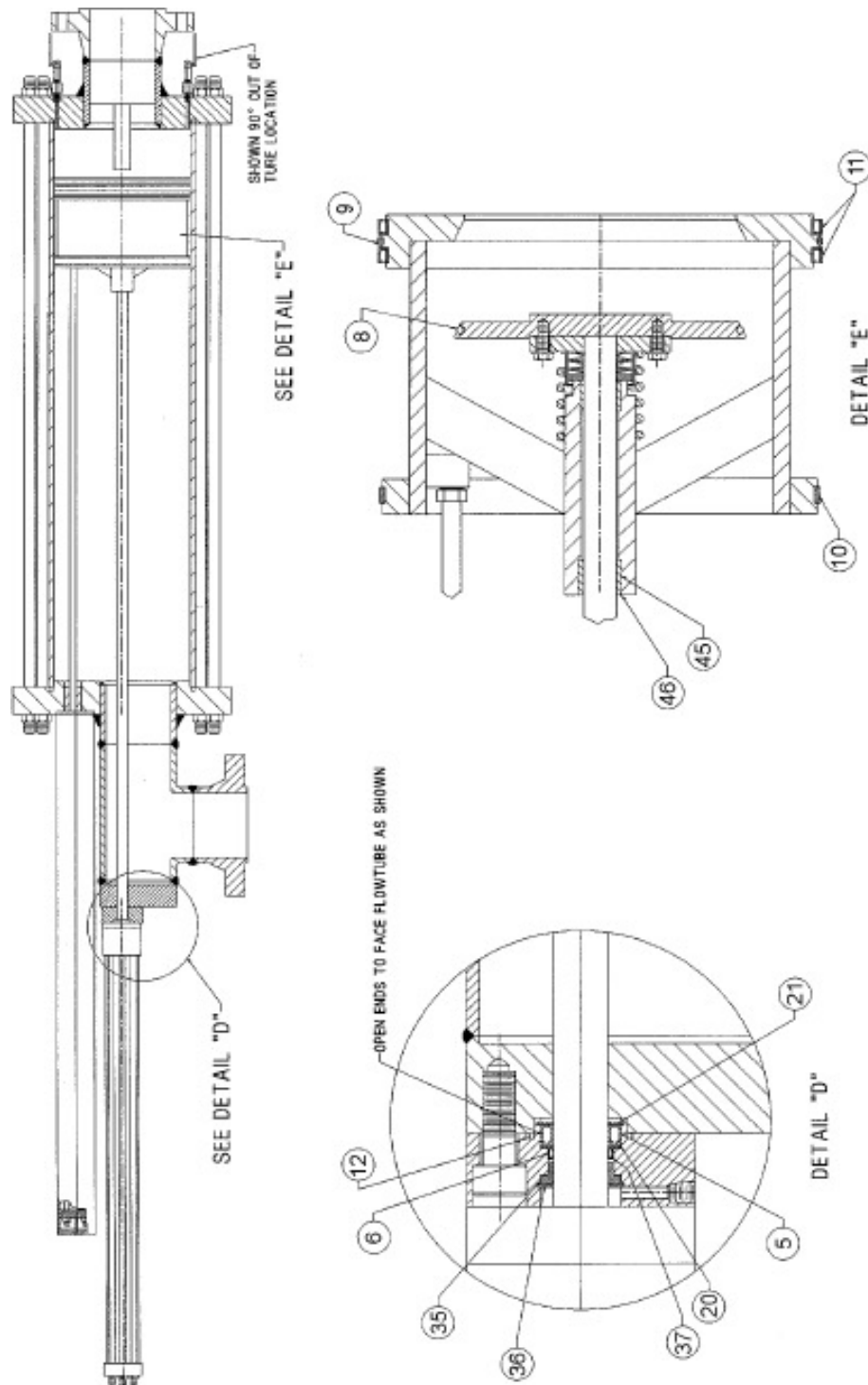

Figure 7-3 Spare parts diagram (Mechanical components)

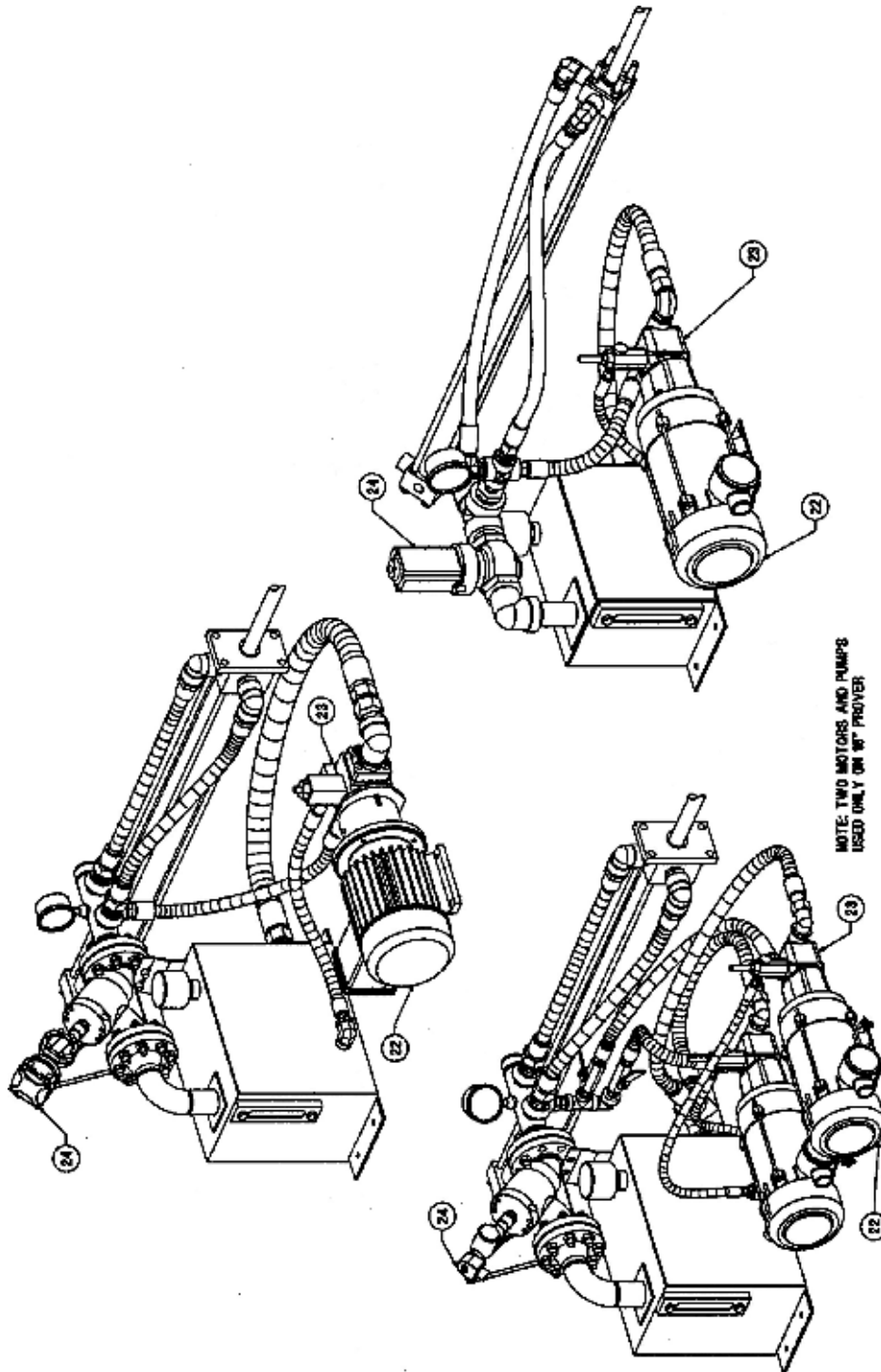

Figure 7-4 Spare parts diagram (Electrical components)

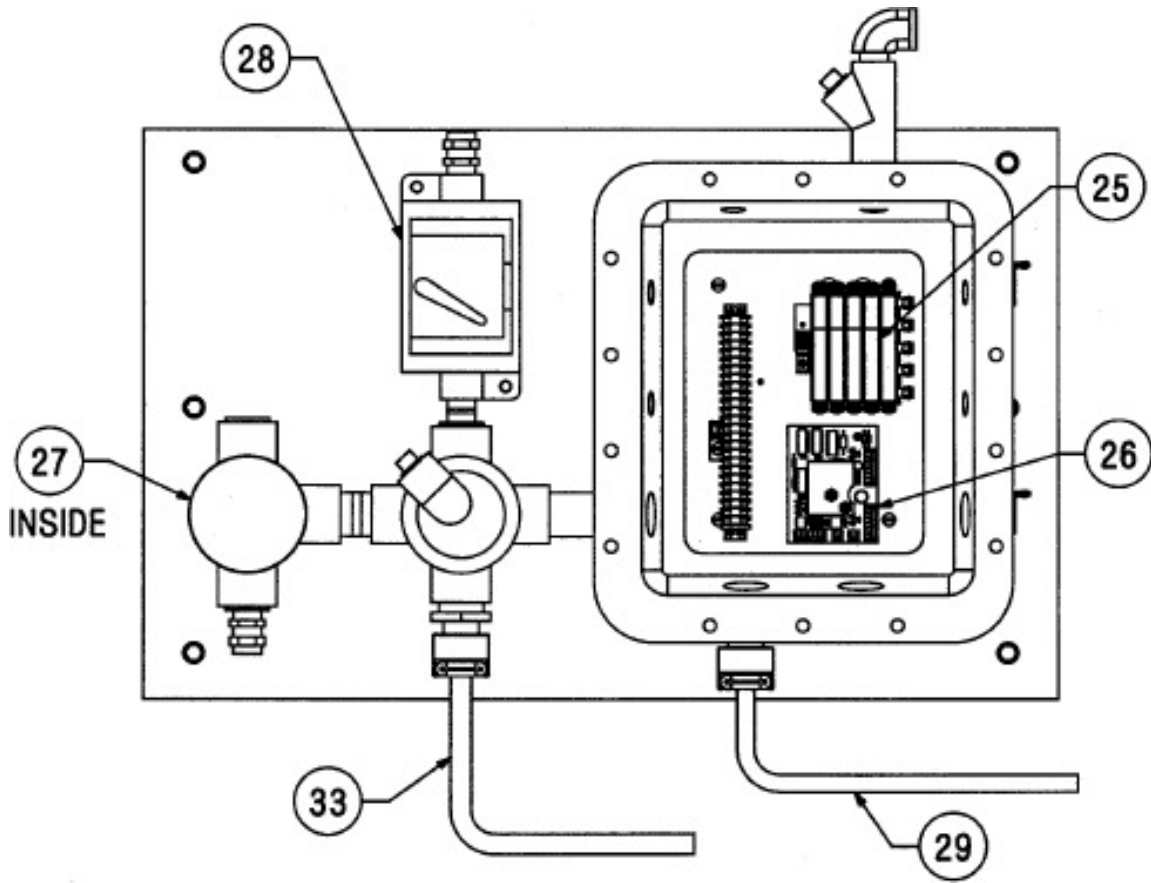
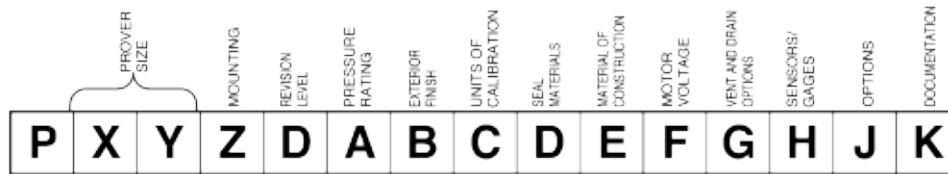

Table 7-2 Compact prover model code



**X Y PROVER SIZE**

		NOMINAL TUBE SIZE	FLANGE SIZE	GPM	LPM	BPH	M3/H
0	B	5 GAL. (20 LITERS)	2"	0.167 TO 250'	0.631 TO 946	0.238 TO 357	0.038 TO 57
2	M	10 GAL. (40 LITERS)	4"	0.67 TO 1,000	2.520 TO 3,780	0.95 TO 1,430	0.15 TO 227
1	2	15 GAL. (60 LITERS)	6"	1.17 TO 1,750	4.415 TO 6,623	1.67 TO 2,500	0.26 TO 397
1	B	30 GAL. (120 LITERS)	8"	2.3 TO 3,500	8.830 TO 13,247	3.30 TO 5,000	0.5 TO 794
2	4	65 GAL. (250 LITERS)	12"	4.7 TO 7,000	17.660 TO 26,495	6.70 TO 10,000	1.1 TO 1,589
3	4	100 GAL. (400 LITERS)	16"	8.4 TO 12,600	31.800 TO 47,691	12 TO 18,000	1.9 TO 2,862
4	0	170 GAL. (650 LITERS)	20"	11.7 TO 17,500	44.160 TO 66,237	16.7 TO 25,000	2.5 TO 3,792

**Z MOUNTING**

- 1. - HORIZONTAL (STD)
- 2. - HORIZONTAL WITH TRAILER
- 3. - VERTICAL STATIONARY
- 4. - VERTICAL HYDRAULIC POSITIONER
- 5. - VERTICAL HYDRAULIC POSITIONER AND TRAILER
- 6. - MIRROR IMAGE HORIZONTAL
- 7. - MIRROR IMAGE HORIZONTAL WITH TRAILER
- 8. - MIRROR IMAGE VERTICAL HYDRAULIC POSITIONER
- 9. - MIRROR IMAGE VERT. HYD. POSITIONER AND TRL.

**D REVISION LEVEL**

**A PRESSURE RATING**

- 1 - 150 LB ANSI 285 PSI @ 100° F ( 1,966 kPa @ 38° C)
- 3 - 300 LB ANSI 740 PSI @ 100° F ( 5,104 kPa @ 38° C)
- 6 - 600 LB ANSI 1480 PSI @ 100° F (10,207 kPa @ 38° C)
- 9 - 900 LB ANSI 2220 PSI @ 100° F (15,310 kPa @ 38° C)
- Z - SPECIAL

**B EXTERIOR FINISH**

- NOTE: COLOR - GREY STANDARD (RAL 7012)
- A - INDUSTRIAL - GREY (SGA 626) NO INSULATION
  - B - MARINE - GREY (SGA 627) NO INSULATION
  - C - N/A
  - D - INDUSTRIAL - GREY (SGA 626) INSULATION - PERMANENT FOAM JACKET
  - E - MARINE - GREY (SGA627) INSULATION - PERMANENT FOAM JACKET
  - F - N/A
  - G - INDUSTRIAL - GREY (SGA 626) INSULATION - DETACHABLE FOAM JACKET
  - H - MARINE - GREY (SGA 627) INSULATION - DETACHABLE FOAM JACKET
  - J - N/A
  - Z - SPECIAL

**C UNITS OF CALIBRATION**

	UNIT OF CALIBRATION	VOLUME
1	GALLONS	SINGLE
2	LITERS	SINGLE
3	GALLONS	DUAL
4	LITERS	DUAL
Z	SPECIAL	

**D SEAL MATERIAL**

	POPPET SEAL O-RING	FLOW TUBE & SEAL SUPPORT O-RING
A	FKM	FKM
B	NITRILE (BUNA-N)	NITRILE
C	PFKM	PFKM
D	PFKM	LOW SWELL NITRIL
E	CHLOROPRENE	CHLOROPRENE
F	FKM	FKM (FOR CRUDE)
Z	SPECIAL	

**E MATERIAL OF CONSTRUCTION**

	FLOWTUBE MATERIAL (CHROME PLATED)	PIPING FLANGE MATERIAL	OPERATING CONDITIONS
1	17-4 PH ST. STL	CARBON STEEL	-20 TO 200°F (-29 TO 93°C)
2	17-4 PH ST. STL	304 ST. STL	-20 TO 200°F (-29 TO 93°C)
5	17-4 PH ST. STL	CARBON STEEL	50 TO 270°F (10 TO 132°C)
6	17-4 PH ST. STL	304 ST. STL	50 TO 270°F (10 TO 132°C)
7	304 ST. STL	LOW CARBON STL.	-50 TO 170°F (-45 TO 77°C)
8	304 ST. STL	304 ST. STL	-50 TO 170°F (-45 TO 77°C)
Z	SPECIAL		

## F MOTOR VOLTAGE

	MOTOR VOLTAGE	PHASE
A	115 VAC/60 HZ	SINGLE PHASE
B	220 VAC/50 HZ	SINGLE PHASE
C	230 VAC/60 HZ	SINGLE PHASE
D	220 VAC/50 HZ	THREE PHASE
E	230 VAC/60 HZ	THREE PHASE
F	380 VAC/50 HZ	THREE PHASE
G	415 VAC/60 HZ	THREE PHASE
H	460 VAC/60 HZ	THREE PHASE
J	208 VAC/60 HZ	THREE PHASE
K	400 VAC/50 HZ	THREE PHASE
Z	SPECIAL	

## G VENT AND DRAIN OPTIONS / INSTRUMENT CONNECTIONS

	VENTS WITH BALL VALVES*	DRAINS WITH BALL VALVES*	SIGHT FLOW	PRESS/TEMP INST. CONNS.
1	NPT CONN	NPTCONN	NO	1" NPT
2	WELDED FLANGES	WELDED FLANGES	NO	1" NPT
3	WELDED FLANGES ONLY (NO BALL VALVES)	WELDED FLANGES ONLY (NO BALL VALVES)	NO	1" NPT
4	WELDED FLANGES	WELDED FLANGES WITH OUTLET AT CENTRAL POINT ON SKID	NO	1" NPT
5	WELDED FLANGES	WELDED FLANGES WITH OUTLET AT CENTRAL POINT ON SKID	YES	1" NPT
6	NPT CONN	NPT CONN	NO	FLANGED
7	WELDED FLANGES	WELDED FLANGES	NO	FLANGED
8	WELDED FLANGES ONLY (NO BALL VALVES)	WELDED SYSTEM WITH OUTLET AT CENTRAL POINT ON SKID	NO	FLANGED
9	WELDED FLANGES	WELDED SYSTEM WITH OUTLET AT CENTRAL POINT ON SKID	NO	FLANGED
0	WELDED FLANGES	WELDED SYSTEM WITH OUTLET AT CENTRAL POINT ON SKID	YES	FLANGED
Z	SPECIAL			

## H SENSORS

	4-20 ma PRESSURE	SMART PRESSURE	4-20 ma TEMPERATUE	SMART TEMPERATURE	(100 OHM) RTD PROBE
A	NONE	NONE	NONE	NONE	NONE
L		0 TO 300 PSI 0 TO 2068 kPa		-328 TO 1,562° F -200 TO 850 °C	
M		0 TO 2,000 PSI 0 TO 13790 kPa		-328 TO 1,562° F -200 TO 850° C	
N		0 TO 300 PSI 0 TO 2068 kPa			X
P		0 TO 2,000 PSI 0 TO 13790 kPa			X
Z	SPECIAL				

NOTE: OPTIONS B - > K ARE NO LONGER AVAILABLE

## J OPTIONS/INDICATORS

	ONE PRESSURE RELIEF VALVE	ONE THERMOWELL WITH CAP	PRESSURE GAGE	DUAL SCALE THERMOMETER
A	NONE	NONE	NONE	NONE
B	X			
C		X		
D	X	X		
E			0 TO 350 PSI (0 TO 2413 kPa)	-40/160°F (-40/70°C)
F			0 TO 350 PSI (0 TO 2413 kPa)	50/300°F (10/150°C)
G	X		0 TO 350 PSI (0 TO 2413 kPa)	-40/160°F (-40/70°C)
H	X		0 TO 350 PSI (0 TO 2413 kPa)	50/300°F (10/150°C)
J		X	0 TO 350 PSI (0 TO 2413 kPa)	-40/160°F (-40/70°C)
K		X	0 TO 350 PSI (0 TO 2413 kPa)	50/300°F (10/150°C)
L	X	X	0 TO 350 PSI (0 TO 2413 kPa)	-40/160°F (-40/70°C)
M	X	X	0 TO 350 PSI (0 TO 2413 kPa)	50/300°F (10/150°C)
N			0 TO 1,400 PSI (0 TO 9653 kPa)	-40/160°F (-40/70°C)
P			0 TO 1,400 PSI (0 TO 9653 kPa)	50/300°F (10/150°C)
R	X		0 TO 1,400 PSI (0 TO 9653 kPa)	-40/160°F (-40/70°C)
S	X		0 TO 1,400 PSI (0 TO 9653 kPa)	50/300°F (10/150°C)
T		X	0 TO 1,400 PSI (0 TO 9653 kPa)	-40/160°F (-40/70°C)
U		X	0 TO 1,400 PSI (0 TO 9653 kPa)	50/300°F (10/150°C)
V	X	X	0 TO 1,400 PSI (0 TO 9653 kPa)	-40/160°F (-40/70°C)
W	X	X	0 TO 1,400 PSI (0 TO 9653 kPa)	50/300°F (10/150°C)
1			0 TO 2,200 PSI (0 TO 15168 kPa)	-40/160°F (-40/70°C)
2			0 TO 2,200 PSI (0 TO 15168 kPa)	50/300°F (10/150°C)
3	X		0 TO 2,200 PSI (0 TO 15168 kPa)	-40/160°F (-40/70°C)
4	X		0 TO 2,200 PSI (0 TO 15168 kPa)	50/300°F (10/150°C)
5		X	0 TO 2,200 PSI (0 TO 15168 kPa)	-40/160°F (-40/70°C)
6		X	0 TO 2,200 PSI (0 TO 15168 kPa)	50/300°F (10/150°C)
7	X	X	0 TO 2,200 PSI (0 TO 15168 kPa)	-40/160°F (-40/70°C)
8	X	X	0 TO 2,200 PSI (0 TO 15168 kPa)	50/300°F (10/150°C)
Z	SPECIAL			

## K APPROVALS / DOCUMENTATION

	<u>ELECTRICAL</u>	<u>COVERAGE</u>	<u>LEVEL</u>
D -	CSA	120 / 230V, 50-60 HZ, 1PH	SEE NOTE 9
J -	UL/CSA	COMPONENTS ONLY	SEE NOTE 9
R -	ATEX	COMPONENTS ONLY	SEE NOTE 9
V -	CSA	208 -230 / 460 VAC, 60 HZ, 3 PH	SEE NOTE 9
1 -	ATEX	220, 380 - 415 VAC, 50 HZ, 1 & 3 PH	SEE NOTE 9
2 -	IECEX	COMPONENTS ONLY	SEE NOTE 9
Z -	SPECIAL		

### NOTES::

- AT RULE A - ALL TRAILERS STANDARD WITH TANDEM AXLE, LEVELING JACKS, ELECTRIC BRAKES 12 VOLT DC RUNNING LIGHTS AND SPARE TIRE.
- AT RULE B - INDUSTRIAL PAINT SYSTEM = EPOXY PRIMER / URETHANE MARINE PAINT SYSTEM = EPOXY PRIMER/ POLYSILOXANE
- AT RULE D - ALL MAIN PISTONS SEALS, HYDRAULIC SHAFT AND OPEICAL SHAFT SEALS ARE MOLYBDENUM DISULFIDE IMPREGNATED TEFLON. ALL MAIN PISTON RIDERS ARE RULON
- AT RULE E - 34" & 40" TEMPERATURE RANGE 20 TO 120°F (-7 TO 49°C) FOR HIGHER TEMPERATURE APPLICATIONS CONSULT FACTORY.
- AT RULE F - MAXIMUM MOTOR VOLTAGE VARIANCE NOT TO EXCEED ±10%.
- AT RULE G - \* EXCEPT WHERE NOTED.
- AT RULE H AND J - X = YES, BLANK = NO
- AT RULE K - CODES A -> D AND R -> U CARRY CSA ELECTRICAL CERTIFICATION FOR STANDARD SKID ONLY AND DOES NOT COVER ADDITIONAL ELECTRICAL OPTIONS. FOR APPLICATIONS REQUIRING ADITIONAL ELECTRICAL OPTIONS, SELECT 'COMPONENTS ONLY' CATEGORY.
- AT RULE K - MTR'S WITH NON-DESTRUCTIVE EXAMINATION (NDE) FOR ALL PRESSURE RETAINING WELD JOINTS. INCLUDES RADIOGRAPHIC (RT), MAGNETIC PARTICLE (MT) OR LIQUID PENETRANT (L:P) TESTING AS APPROPRIATE FOR JOINT TYPE AND MATERIAL OF CONSTRUCTION WITH DOCUMENTED WELDING AND NDE PROCEDURES.



# BRODIE

INTERNATIONAL



Phone: +1 (912) 489-0200  
+1 (888) 849-1481  
Email: [sales@brodieintl.com](mailto:sales@brodieintl.com)



P.O. Box 450 (30459-0450)  
19267 Highway 301 North  
Statesboro, GA 30461 USA

