

Model BV Series Piston Control Valves

Model	Function	Size					
		2"	3"	4"	6"	8"	12"
BV02	Check Valve
BV03	No Controls
BV10	On-Off Solenoid (N.C.)
BV11	On-Off Solenoid (N.O.)
BV50	Pressure Reducing
BV54	Flow Limiting
BV60	Back Pressure Control
BV70	Differential Control
BV86	Mechanical 2-Stage
BV88	Digital Control
BV89	Rate of Flow 2-Stage Set Stop

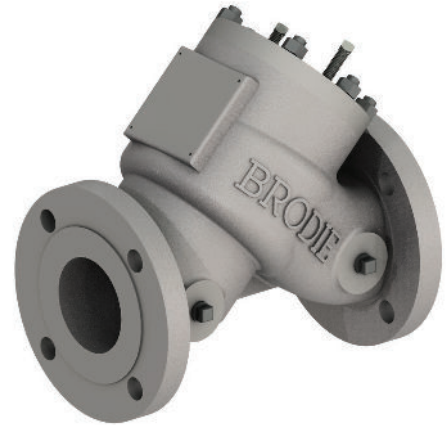

Table of Contents

- 1 Read Me First 5
- 2 Essential Instructions 6
- 3 Warranty Claim Procedures 10
- 4 Receipt of Shipment 14
- 5 Return of Equipment 14
- 6 Storage 15
- 7.1 Types of Pilots..... 16
- 7.2 Design Features..... 16
- 8 Specifications 17
- 9 Installation and Operation 21
- 9.1 Models BV02 and BV03, Check Valve 21
- 9.2 Models BV10 and BV11, On/Off Control Valve..... 21
- 9.3 Model BV28, Power Cylinder Operated Control Valve..... 21
- 9.3.1 Model BV28 Series Wiring Schematic..... 22
- 9.4 Model BV50, Pressure Reducing Valve..... 22
- 9.5 Model BV54, Flow Limiting Valve..... 22
- 9.6 Model BV60, Back Pressure/Relief Valve..... 23
- 9.6.1 Model BV60, Recommended Installation Instructions 23
- 9.6.2 Model BV60, Adjustment and Startup Procedure..... 24
- 9.6.3 Model BV60, Typical Installation..... 25
- 9.7 Model BV70, Differential Control Valve..... 25
- 9.8 Model BV86, Two-Stage Mechanical Control Valve..... 26
- 9.9 Model BV88 Digital Control Valve..... 26
- 9.9.1 Model BV88, Recommended Installation Instructions..... 26
- 9.9.2 Model BV88, Adjustment and Startup Procedure..... 27
- 9.10 Model BV89, Two-Stage Control Valve..... 28
- 10 Maintenance..... 31
- 10.1 Disassembly of the Cylinder Assembly with Valve Position Indicator 31
- 10.2 Reassembly of Cylinder Assembly With Valve Position Indicator 34
- 10.3 Disassembly of Cylinder Assembly without Valve Position Indicator 34
- 10.4 Reassembly of Cylinder Assembly without Valve Position Indicator 35
- 10.5 Aggressive Products Cylinder Disassembly 36
- 10.6 Cup-Seal Replacement on Existing “AP” Option Piston 36
- 10.7 Torque Specifications for Cylinder Head Bolts (ft/lb.) 37
- 10.8 Disassembly of Model BV28 Series Power Cylinder 38
- 9.9 Model BV28 Series Power Cylinder Shaft Assembly 41
- 9.10 Model BV28 Series Power Cylinder Valve Assembly 42
- 10 Troubleshooting 49
- 11 Parts Lists 52
- 11.1 BV Series Valve Illustrated Parts List 53
- 11.1.2 BV Series Valve Part Numbers 54

Table of Contents

- 11.2.1 2" Valve Cylinder Illustrated Parts List 55
- 11.2.2 2" Valve Cylinder Part Numbers 56
- 11.2.3 Valve Seal Kits 57
- 11.3.1 3", 4", and 6" Valve Cylinder Illustrated Parts List 58
- 11.3.2 3" Valve Cylinder Part Numbers 59
- 11.3.3 4" Valve Cylinder Part Numbers 60
- 11.3.4 6" Valve Cylinder Part Numbers 61
- 11.3.5 8" Valve Cylinder Part Numbers 62
- 11.3.6 12" Valve Cylinder Part Numbers 63
- 11.4.1 Model BV28 Illustrated Parts List 64
- 11.4.2 Model BV28 Part Numbers 65
- 11.5.1 Model BV28 Shaft Assembly Illustrated Parts List 67
- 11.5.2 Model BV28 Shaft Assembly Part Numbers 67
- 11.6.1 Model BV28 Single Microswitch Assembly Illustrated Parts List 68
- 11.6.2 Model BV28 Single Microswitch Assembly Part Numbers 69
- 11.7.1 Model BV28 Double Microswitch Assembly Illustrated Parts List 70
- 11.7.2 Model BV28 Double Microswitch Assembly Part Numbers 71
- Appendix A 72**
- Appendix B 73**

1 Read Me First

Notice

Brodie International, a Brodie Meter Co., LLC Company ("Brodie") shall not be liable for technical or editorial errors in this manual or omissions from this manual.

Brodie makes no warranties, expressed or implied, including the implied warranties of merchantability and fitness for a particular purpose with respect to this manual and, in no event, shall Brodie be liable for any special or consequential damages including, but not limited to, loss of production, loss of profits, etc.

Product names used herein are for manufacturer or supplier identification only and may be trademarks/registered trademarks of these companies. The contents of this publication are presented for informational purposes only, and

while every effort has been made to ensure their accuracy, they are not to be construed as warranties or guarantees, expressed or implied, regarding the products or services described herein or their use or applicability. We reserve the right to modify or improve the designs or specifications of such products at any time.

Brodie does not assume responsibility for the selection, use or maintenance of any product. Responsibility for proper selection, use and maintenance of any Brodie product remains solely with the purchaser and end-user.

No part of this work may be reproduced or copied in any form or by any means - graphic, electronic or mechanical - without first receiving the written permission of Brodie International.

2 Essential Instructions

General

Brodie International designs, manufactures and tests its products to meet many international standards. As the instruments are sophisticated technical products they must be installed, used and maintained properly to ensure they continue to operate within their normal specifications. The following instructions must be adhered to and incorporated into onsite safety programs where possible.

Read all instructions prior to installing, operating, and servicing the product. If this instruction manual is not the correct manual, telephone +1 912 489 0200 and the requested manual will be provided.

Save this instruction manual for future reference. If you do not understand any of the instructions, contact your Brodie representative for clarification.

Follow all warnings, cautions, and instructions marked on and supplied with the product. Inform and educate your personnel in the proper installation, operation, and maintenance of the product. Install your equipment as specified in the installation instructions of the appropriate instruction manual and per applicable local and national codes. Connect all products to the proper electrical and pressure sources.

To ensure proper performance, use qualified personnel to install, operate, update, program, and maintain the product. When replacement parts are required, ensure that qualified personnel use replacement parts specified by the manufacturer.

Unauthorized parts and procedures can affect the product's performance and place the safe operation of your process at risk. Look-alike substitutions may result in fire, electrical hazards, or improper operation.

Ensure that all equipment doors are closed and protective covers are in place, except when maintenance is being performed by qualified personnel, to prevent electrical shock and personal injury.

It is the customer's responsibility to provide fire prevention measures and equipment per local regulations.

Use of this equipment for any purpose other than its intended purpose may result in property damage and/or serious personal injury or death.

Essential Instructions for Measuring Equipment, Including the European Union (Directive 2014/32/EU MID)

Although measurement transducers are not specifically included in the MID regulations as they do not form a complete measuring instrument system, in accordance with Article 1 and 4, Annex I and Annex VII, Brodie Meter Co., LLC implements the same stringent regulations for all products and tests to the same standards which are used for complete measuring instrument systems.

The complete system must contain all the necessary components to meet the requirements of the local regulations. These components may include pumps, air eliminators, strainers, valves, flow computers, etc. The unit must be sealed in accordance with the local regulations; it is the end user's

responsibility to ensure this happens.

Flow measuring devices are provided with two labels which specify flow ranges. The name plate label, which includes the factory serial number, details the operating flow range. This is the flow range the device will operate within without causing damage. The custody transfer label details the working flow range associated with a particular weights and measures approval.

It should be noted that these may not be the same; therefore, in trade applications, the flow ranges specified on the custody transfer label should be followed.

Essential Instructions for Electrical Equipment, Including the European Union (Directive 2014/30/EU and 2014/32/EU)

This unit may contain Electrostatic sensitive circuit boards. Electrostatic safety precautions should be taken to prevent damage.

When connecting wiring it is good practice to use shielded cable. The shield should be connected to earth at the read out or control systems end of the cable; the other end of the shield should not be connected.

This wiring practice is mandatory in order to comply with the requirements for electromagnetic compatibility as per the EMC directive 2014/30/EU and MID 2014/32/EU of the council of the European Union.

It is the end user's responsibility to ensure that all protective covers are in place to prevent electrical shock and/or personnel injury.

Essential Instructions for Pressure Containing Equipment, Including the European Union (Directive 2014/68/EU)

When installing the equipment, bolting must conform to the requirements of ASME B16.5, paragraph 5.3, and to the material requirements of ASME B16.5, Table 1B. Gaskets must conform to the requirements of ASME B16.20.

Although it is not expected for the device to be used in a service where it would come in to contact with unstable fluids, it is the end user's responsibility to assess any risks and take any precautions necessary.

It is the end user's responsibility to ensure that piping and other attachments connected to the Brodie instrument do not place adverse stresses upon it, the design of the instrument has not been assessed for the effects of traffic, wind or earthquake loadings.

It is the end user's responsibility to ensure that the instrument is mounted, when required on suitable supporting foundations.

It is the end user's responsibility to install the device in a well-designed system to avoid potential hazards such as water hammer, vacuum collapse or uncontrolled chemical reactions.

It is the end user's responsibility to provide fire protection measures and equipment in accordance with the local regulations.

It is the end user's responsibility to install suitable straining and air/gas elimination systems.

The instrument has been designed without allowance for corrosion or other chemical attack. The end user should implement a periodic inspection and maintenance program to ensure that none of the instruments pressure containing components have been subject to any corrosion. It is possible to examine the instrument for evidence of corrosion through the inlet and the outlet.

When the ambient temperatures are below the minimum operating temperature specified on the device, it is the end user's responsibility to ensure that the device is warmed to an appropriated temperature before being pressurized.

Do not exceed the operating pressure and temperature limits of the instrument as stamped on the nameplates.

It is the customer's responsibility to install this equipment in a system that provides adequate over-pressure protection and that limits pressure surges to 10% of the maximum allowable working pressure of the instrument.

It is the end user's responsibility to provide fire protection measures and equipment in accordance with the local regulations.

Essential Instructions for Equipment to be Used in Hazardous Locations, Including the European Union (Directive 2014/34/EU)

Any Hazardous area approval applies to equipment without cable glands. When mounting the flame-proof enclosure in a hazardous area only cable glands/conduit seals certified to meet or exceed the rating of the equipment should be used, refer to the type approval documentation for further details. Cable glands and cable must be suitable for the operating temperature of the device under its rated conditions, this is especially important if the device has an operating temperature above 1580F (700C). It is the end user's responsibility to ensure this happens.

The meter has been provided with an approved sealing device in one of the cable entries, the other entry has been closed with a plastic cap plug. It is the end user's responsibility to remove the cap plug and replace it with a suitable cable gland or conduit seal before the equipment is put into service.

It is the end user's responsibility to ensure, when the instrument is located in a hazardous area, that all cable glands and conduit seals are installed in accordance with all local codes and regulations.

It is the end user's responsibility to ensure that before opening an electronic enclosure in a flammable atmosphere that all the electrical circuits have been interrupted.

If replacement of the screws which secure the sensor housing, the UMB cover of the electronic register and its cover, are required, they must be replaced with either factory direct parts or M6-1x16 (6g) mm hex head socket screws of equal length. The screws must be made from stainless steel grade A1-70 or A2-70 and be torqued to a value of 55 inch lbs. upon installation. It is the end user's responsibility to ensure this happens.

It is the end user's responsibility to assess the

maximum surface temperature of the device and the equipment the device is attached to and located next to as this may exceed the temperature ratings of the device itself. If this happens, additional safety precautions will need to be implemented by the end user.

Flame proof housings contain Aluminum. The composition of these enclosures is carefully maintained to prevent any risk of an ignition source it is the end users responsibility to ensure that the housing is not struck by rusty tools or objects.

If the equipment is to be installed in an area where dust deposits and build up are to be expected, a maintenance plan should be arranged to include regular removal of the dust build up. This will prevent the dust from forming a possible source of ignition.

The power supply requirements for this product are specified within the operating and maintenance manual, it is the end user's responsibility to operate the product within these specified limits.

The instrument may contain surfaces that constitute flames paths, these surfaces should not contain any marks or scratches. If any are present the factory or the local representative should be contacted immediately to obtain a new housing as the safety of the enclosure may be impaired. It is the end user's responsibility to inspect these surfaces every time the enclosure is opened.

When flanged flame paths are reassembled the gap between them should be less than 0.0015" (0.038 mm) such that a 1/2" (12.5mm) wide 0.0015" (0.038 mm) feeler gauge will not enter the gap more than 1/8" (3mm). It is the end user's responsibility to ensure this happens each time the enclosure is reassembled.

3 Warranty Claim Procedures

These terms and conditions, the attendant quotation or the acknowledgement, and all documents incorporated by reference therein, binds Brodie Meter Co., LLC, who issues the quotation or acknowledgment for the provision of services and/or the sale of goods (except as provided in Section 11), to be provided hereunder by seller (Brodie Meter Co., LLC) hereinafter Seller, and the buyer, hereinafter Buyer, and constitute the entire agreement (Agreement) between Buyer and Seller regarding such sale and/or provision. To the extent not in conflict with the superseding terms of the Sales Order, these terms and conditions will be in force.

1. **PRICES:** Unless otherwise specified by Seller, Seller's price for the Goods and/or Services shall remain in effect for thirty (30) days after the date of Seller's quotation or acceptance of the order for the Goods/Services, whichever is delivered first, provided an unconditional, complete authorization for the immediate manufacture and shipment of the Goods and/or provision of Services pursuant to Seller's standard order processing procedures is received and accepted by Seller within such time period. If such authorization is not received by Seller within such thirty (30) day period, Seller shall exercise the right to change the price for the Goods/Services to Seller's price in effect for the Goods/Services at the time the order is released to final manufacture. Notwithstanding any of the foregoing to the contrary, the price for Goods/Services sold by Seller, but manufactured by others, shall be Seller's price in effect at the time of shipment to Buyer.

2. **DELIVERY, PASSING OF RISK, RETENTION OF TITLE, AND DOCUMENTATION:** All shipping dates are approximate and are based upon Seller's prompt receipt of all necessary information from Buyer to properly process the order. Any agreed

trade term shall be construed in accordance with the INCOTERMS® in force at the formulation of the contract. If no trade term has been specifically agreed, the delivery shall be F.O.B. Brodie Factory, FCA Brodie Factory, or EXWORKS Brodie Factory. Notwithstanding, any provisions to the contrary in this or other documents related to this transaction, the passing of risk of loss thereto shall transfer to Buyer upon delivery to the first freight carrier at the shipping point. The Goods shall remain the property of the Seller until paid for in full to the extent that such retention of title is valid under the relevant law. The retention of title shall not affect the passing of risk. The Seller shall provide Buyer with that data/documentation which is specifically identified in the contract. If additional copies of data / documentation or non-standard data/documentation are to be provided by Seller, they shall be provided to Buyer at Seller's price then in effect.

3. **EXCUSE OF PERFORMANCE:** Seller shall not be liable for delays in performance or for non-performance due to acts of God, war, riot, fire, labor trouble, unavailability of materials or components, explosion, accident, compliance with governmental requests, laws, regulations, orders or actions, or other unforeseen circumstances or causes beyond Seller's reasonable control.

4. **CHANGE, CANCELLATION AND RESTOCKING CHARGES:** Once an order has been acknowledged by the Seller, any changes requested by the Buyer must be communicated to the Seller. The Seller will notify the Buyer of any fees associated with the requested change. Buyer may terminate or suspend its non-shipped order for any or all of the Goods/Services covered by the Agreement, provided that Buyer gives Seller reasonable advance written notice of such termination or suspension and reimburses Seller accordingly:

25% of Net Order after Release to Engineering, 50% of Net Order after Release to Manufacturing, 75% of Net order after 50% Manufacture Complete and 100% of Net Order once Manufacturing is complete. Any request for return of product already shipped to Buyer will be at the discretion of Brodie. If so approved, a Return Authorization will be provided and a restocking fee assessed.

5. LIMITED WARRANTY: Subject to the limitations contained in Section 2 herein and except as otherwise expressly provided herein, Brodie Meter Co., LLC ("Brodie") warrants the Goods-manufactured by Brodie will be free from defects in materials or workmanship under normal use and care until the expiration of the applicable warranty period. Goods are warranted for twelve (12) months from the date of installation and 18 months from date of shipment, whichever occurs first. Consumables and Services are warranted for a period of 90 days from the date of shipment or completion of the Services. Products purchased by Brodie from a third party for resale to Buyer ("Resale Products") shall carry only the warranty extended by the original manufacturer. Buyer agrees that Brodie has no liability for Resale Products beyond making a reasonable commercial effort to arrange for procurement and shipping of the Resale Products. If Buyer discovers any warranty defects and notifies Brodie thereof in writing during the applicable warranty period, Brodie shall, at its option, repair or replace, that portion of the Goods found by Brodie to be defective or refund the purchase price of the defective portion of the Goods/Services. All replacements or repairs necessitated by inadequate maintenance, normal wear and usage, unsuitable power sources, unsuitable environmental conditions, accident, misuse, improper installation, modification, repair, storage or handling, or any other cause not the fault of Brodie, are not covered by this limited warranty, and shall be at Buyer's expense. Brodie shall not be obligated to pay any costs or charges incurred by Buyer or any other party except as may be agreed upon in writing in advance by an authorized Brodie representative. All costs of dismantling,

reinstallation and freight and the time and expenses of Brodie's personnel for site travel and diagnosis under this warranty clause shall be borne by Buyer unless accepted in writing by Brodie. Brodie is not responsible for damages that incur during shipment to Buyer for shipments that are F.O.B. Brodie Factory, FCA Brodie Factory, or EXWORKS Brodie Factory. Shipping charges for goods returned to Brodie under warranty will be at Buyer's expense. Products found not to be warranted can be repaired and returned at Buyer's expense and return charges born by Brodie will be added to the cost of repair or returned to Buyer "as received" at Buyer's expense. Insurance for returned products will be at Buyer's expense. For all returned products please package to prevent damage, or future damage during shipment. Make sure the products are cleaned, free from grease oil, chemicals and other materials that may hamper defect detection and impede repair. All returned items must be accompanied with a MSDS for the products that have been in contact with the equipment, including cleaning agents. A decontamination statement, RMA, and Customer Problem Report must also accompany equipment returned. Product received in an unsuitable condition will be returned at Buyer's expense without being examined. Goods repaired, and parts replaced during the warranty period shall be in warranty for the remainder of the original warranty period or ninety (90) days, whichever is longer. This limited warranty is the only warranty made by Brodie and can be amended only in a writing signed by an authorized representative of Brodie. Except as otherwise expressly provided in the Agreement, there are no representations or warranties of any kind, expressed or implied, as to merchantability, fitness for a particular purpose, or any other matter with respect to any of the goods or services. It is understood that corrosion or erosion of materials is not covered by our guarantee unless the Buyer has notified the Seller the product will be used in an environment conducive to corrosion and/or erosion and the product has been coated with Brodie's recommended method of protection against corrosion / erosion.

6. **LIMITATION OF REMEDY AND LIABILITY:** Brodie shall not be liable for damages caused in delay in performance. The sole and exclusive remedy for breach of warranty hereunder shall be limited to repair, correction, replacement or refund of purchase price under the limited warranty clause in section 5. In no event, regardless of the form of the claim or cause of action (whether based in contract, infringement, negligence, strict liability, other tort or otherwise), shall Brodie's liability to buyer and/or its customers exceed the price to buyer of the specific goods manufactured or services provided by Brodie giving rise to the claim or cause of action. Buyer agrees that in no event shall Brodie's liability to buyer and/or its customers extend to include incidental, consequential or punitive damages. The term "consequential damages" shall include, but not be limited to, loss of anticipated profits, loss of use, loss of revenue and cost of capital.

7. **PATENTS:** Subject to the limitations contained in Section 6, Seller shall defend any suits brought against Buyer based on a claim that use of the Goods manufactured by Seller constitutes an infringement of a valid patent of the United States, and shall pay any damages awarded therein against Buyer, provided that Buyer: promptly notifies Seller in writing of the filing of such suit or the threat thereof; permits Seller to control completely the defense or compromise of such claim of infringement; and provides all reasonable assistance and cooperation requested by Seller for the defense of such suit. In the event that only the Goods manufactured by Seller are held to be infringing in such suit and their use is enjoined, Seller shall, at its sole option and expense, provide a commercially reasonable alternative, including, but not limited to, procuring for Buyer the right to continue using the Goods, replacing them with a non-infringing product or modifying them so they become non-infringing. Buyer agrees that Seller shall not be liable for infringement, and that Buyer shall fully indemnify Seller therefore, if infringement is based upon the use of Goods in connection with Goods not manufactured by Seller or in a manner for which the Goods were not designed by

the Seller or if the Goods were not designed by the Seller or if the Goods were designed by the Buyer or were modified by or for the Buyer in a manner to cause them to become infringing.

8. **INSTALLATION:** Buyer shall be responsible for receiving, storing, installing, starting up and maintaining all Goods. Seller shall provide a quotation for services to assist Buyer in these functions if requested.

9. **TAXES:** Any tax or governmental charge payable by the Seller because of the manufacture, sale or delivery of the Goods, or provision of Services, may at Seller's option be added to the price herein specified. The foregoing shall not apply to taxes based upon Seller's net income.

10. **TERMS OF SHIPMENT AND PAYMENT:** Subject to the approval of Seller's Credit Department, shipping terms are F.O.B. Brodie Factory, FCA Brodie Factory, or EXWORKS Brodie Factory. Payment terms are subject to the approval of Seller's Credit Department and may vary based on Buyer's creditworthiness. Payment is expected, in U.S. currency, as per the prearranged agreement between the Buyer and Seller stated on the sales order. In the absence of such agreement, payment, in U.S. currency, is due Net30 days from the date of invoice. If any payment owed to Seller hereunder is not paid when due, it shall bear interest, at a rate to be determined by Seller which shall not exceed the maximum rate permitted by law, from the date on which it is due until it is received. Seller shall have the right, among other remedies, either to terminate the Agreement or to suspend further deliveries under this and/or other agreements with Buyer in the event Buyer fails to make any payment hereunder when due. Buyer shall be liable for all expenses incurred for collection of past due amounts, including attorneys' fees.

11. **STORAGE FEES**

1. Per diem charges are applicable when equipment is held beyond the acknowledged ready for shipment date.

Per diem storage charges will be assessed on each calendar day excluding the date of readiness. The customer shall indemnify and hold Brodie International harmless from any and all liability and expense for such damages that might result from extended storage beyond six months. Brodie may place the cargo in another warehouse facility with all charges associated with the transfer and storage to be paid by the customer.

12. SOFTWARE AND FIRMWARE: Notwithstanding any other provision herein to the contrary, Seller or applicable third-party owner shall retain all rights of ownership and title in its respective firmware and software, including all copyrights relating to such firmware and software and all copies of such firmware and software. Except as otherwise provided herein, Buyer is hereby granted a nonexclusive, royalty free license to use firmware and software, and copies of firmware and software, incorporated into the Goods only in conjunction with such Goods and only at the Buyer's plant site where the Goods are first used. Buyer may negotiate with Seller separate licenses to use such copies and firmware and software at other plant sites. Buyer's use of certain firmware (as specified by Seller) and all other software shall be governed exclusively by Seller's and/or third-party owner's applicable license terms.

13. BUYER SUPPLIED DATA: To the extent that Seller has relied upon any specifications, information, representation of operating conditions or other data or information supplied by Buyer to Seller in the selection or design of the Goods and/or provision of the Services and the preparation of Seller's quotation, and in the event that the specifications or information is inaccurate or actual operating conditions differ, any warranties or other provisions contained herein which are affected by such conditions shall be null and void, unless otherwise mutually agreed upon in writing.

14. GENERAL PROVISIONS: (a) Buyer shall not assign its rights or obligations under the Agreement without Seller's prior written consent. (b) There are no understandings, agreements or representations, express or implied, not specified in the

Agreement. (c) No action, regardless of form, arising out of transactions under the Agreement, may be brought by either party more than two (2) years after the cause of action has accrued. (d) Any modification of these terms and conditions must be set forth in a written instrument signed by a duly authorized representative of Seller. (e) The Agreement is formed and shall be construed, performed and enforced under the laws of the state of Georgia. However, Buyer and Seller agree that the proper venue for all actions arising under the Agreement shall be only in the State where the Goods involved in such actions were manufactured. (f) GOODS AND SERVICES PROVIDED HEREUNDER ARE NOT SOLD OR INTENDED FOR USE IN ANY NUCLEAR OR NUCLEAR RELATED APPLICATIONS. Buyer (i) accepts Goods and Services in accordance with the restriction set forth in the immediately preceding sentence, (ii) agrees to communicate such restriction in writing to any and all subsequent purchasers or users and (iii) agrees to defend, indemnify and hold harmless Seller from any and all claims, losses, liabilities, suits, judgments and damages, including incidental and consequential damages, arising from use of Goods and Services in any nuclear or nuclear related applications, whether the cause of action be based in tort, contract or otherwise, including allegations that the Seller's liability is based on negligence or strict liability. (g) The 1980 United Nations Convention on Contracts for the International Sale of Goods does not apply to this Agreement. (h) If any provision of the Agreement is invalid under any statute or rule of law, such provision, to that extent only, shall be deemed to be omitted without affecting the validity of the remainder of the Agreement.

4 Receipt of Shipment

When you receive your equipment inspect the outside of the packing case for damage which may have incurred during shipping. Damage incurred during shipment is the responsibility of the carrier and is not part of the factory warranty. If the packing case is damaged, notify the local carrier immediately.

If the package is in good condition remove the en-

velope containing the packing list and carefully remove the equipment and all components included in the shipment from the packing case. Inspect for damaged or missing parts, referring to the packing list, and prior to discarding the packing material.

If Items are missing from your shipment, contact your sales representative. Your sales order number will be required.

5 Return of Equipment

If the equipment must be returned to the factory for repair or replacement, a Returned Materials Authorization (RMA) must be included with the components.

RMA forms may be obtained from your sales representative or from the Product Service Department. In addition to the RMA, a Material Safety Data Sheet and a Decontamination Statement must be included with Items being returned to the factory. A Decontamination Statement is included in the back of this manual.

If the equipment is removed from service it must be thoroughly drained and neutralized before it is packed for shipment. Care must be taken to ensure that product removed from the equipment is disposed of in accordance with all applicable local, state and federal regulations.

The flanges should be sealed to keep residual fluid from leaking out of the meter during transport. The type of flange seal required will vary with the form of transportation used. Contact the carrier for specific instructions.

The equipment should be securely mounted on a wooden skid for shipment. The original container or a solid wooden box should be used to protect the exterior of the components.

When packing the components for return to the factory, place the RMA and a copy of the packing list that was delivered with the equipment inside an envelope. Place the envelope inside the shipping container with the Item being returned and reference the RMA number on the outside of the shipping container.

Equipment returned to the factory without the proper documentation will be returned to sender at their expense.

Ship the container to:
Brodie Meter Co., LLC
Product Service Department
19267 Highway 301 North
Statesboro, GA 30461, USA

Phone: +1 (912) 489-0200
Fax: +1 (912) 489-0294
service@brodieintl.com

6 Storage

Brodie International instruments are precision devices and should be handled and stored with care. They should not be subjected to rough or improper handling or stored in an environment where moisture, extreme temperatures, or foreign material can damage the meter.

The inlet and outlet flange covers should remain on the instrument until the unit is ready for installation.

If extended storage is required it is recommended that the instrument be placed in an environmentally controlled warehouse.

If this is not possible the instrument should be stored in a waterproof lined wooden box. Desiccant packs should be taped to the inside of the instrument end connections before they are sealed to reduce the effect of humidity on the equipment and accessories. Caution must be used to ensure desiccant packs are removed prior to installation.

Depending on the storage time it may also be preferable to use a compatible corrosion inhibitor.

If the meter is removed from service for an extended period of time it should be flushed with a light oil before being placed into storage.

7 Description

General

The Brodie Control Valve features a two-piece, aggressive products cylinder, characterized ports, and an optional position indicator. Pilots and other optional accessories enable the valve to perform a variety of control functions such as regulating rate of flow, pressure relief, surge control, etc. Different valve functions are provided in a single standard body and controlled with different pilots that are used to steer the valve piston open or closed as required by the application.

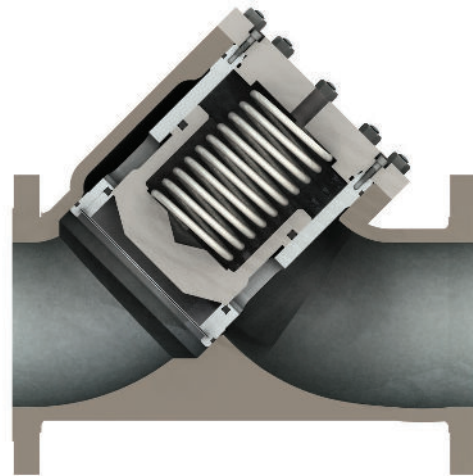

7.1 Types of Pilots

On/Off Pilots are electrically operated pilots which force the valve to open or close.

Pressure regulating pilots allow the valve to be throttled to any degree to provide various pressure control schemes. These valves are totally self-regulating and require no external actuation, pressure

measurement or regulation, or energy source. Once the pilots are set they will continue to function automatically until such time that settings are changed.

Control combinations may be combined to provide multiple control functions in a single valve.

7.2 Design Features

Brodie Valves are pressure balanced, single seated and pilot operated. The valves are hydraulically powered, using the flowing fluid product stream as the power medium. Pilot operated valves are equipped with a needle valve in the pilot supply line for adjusting the closing rate and for sensitivity control.

The Aggressive Product (hereby referred to as "AP") option valve cylinder incorporates a combination of seals and O-ring materials to provide optimum performance in AP applications. Specify AP Option at time of order when valve is to be used on products which may affect standard seals.

All Brodie valves feature a modular construction with no diaphragms or stuffing boxes to ensure long service life. All valve internal parts, including seal ring, can be removed without disturbing line

connections. Valve cylinder assemblies are available as replacement kits.

The 45° body design assures high capacity and low pressure drop through the valve, while tapered ports allow for better low flow response.

The valve piston spring has equal front and rear surface areas. This means that every Model BV valve has check valve functionality. O-ring seals provide positive, bubble-tight shut-off and zero leakage - no additional system check valve is required to prevent reverse flow. The valve will only open when upstream pressure is sufficient to overcome spring force.

The linear relationship between percentage open and flow rate gives much better control and prevents instability, especially at low flow rates.

8 Specifications

Materials of Construction

	Material
Main Valve Body	Steel, ASTM-A216-GR-WCB
Main Valve Cylinder	17-4 PH Stainless Steel
Main Valve Piston	Stainless Steel
Seat Ring	Stainless Steel
Seals	Viton-A

Pilot Spring Ranges

150 - 300 lb. Valves	
PSI *	kPa
0 - 20	0 - 138
0 - 40	0 - 276
10 - 50 **	69 - 345
30 - 80	207 - 552
70 - 180	483 - 1241
150 - 350	1034 - 2413
350 - 650	2413 - 4482

* Spring selection is based on control pressure set point

** Model BV89 Only

Pressure and Temperature Ratings

Pressure Class	Maximum Safe Working Pressure (100°F)	Maximum Safe Working Temperature
150 lb. ANSI	285 psi (1965 kPa)	Standard: 150°F (66°C) Optional "AP": 250°F (121°C)
300 lb. ANSI	740 PSI (5100 kPa)	

Approx. Shipping Weight and Volume

Model	Size	150# Lbs.	300#	150# Kg	300#
BV Series with Single Pilot	2"	60	110	27.22	49.90
	3"	105	135	47.63	61.24
	4"	140	276	63.50	125.19
	6"	250	280	113.40	127
	8"	370		167.83	
	12"				

Dimensions and Approvals

Valve Size			2"	3"	4"	6"	8"	12"
Dimensions [A]	150#	inch	10 1/4	11	13	17	22 1/2	30 7/8
		mm	260	279	330	432	571	784
	300#	inch		13 1/8	14 1/2	17 7/8		
		mm		333	368	454		
Capacity		*Cv-GPM	90	190	315	700	1300	2950
Pressure Approvals	150 lb.		SEP	SEP	SEP	CRN, PED	CRN, PED	CRN, PED
	300 lb.		PED	PED	PED			
Electrical Approvals	CSA, UL, ATEX, IECEx, for all sizes							

* Cv based on wide open valve utilizing water at 60F (15.6C)

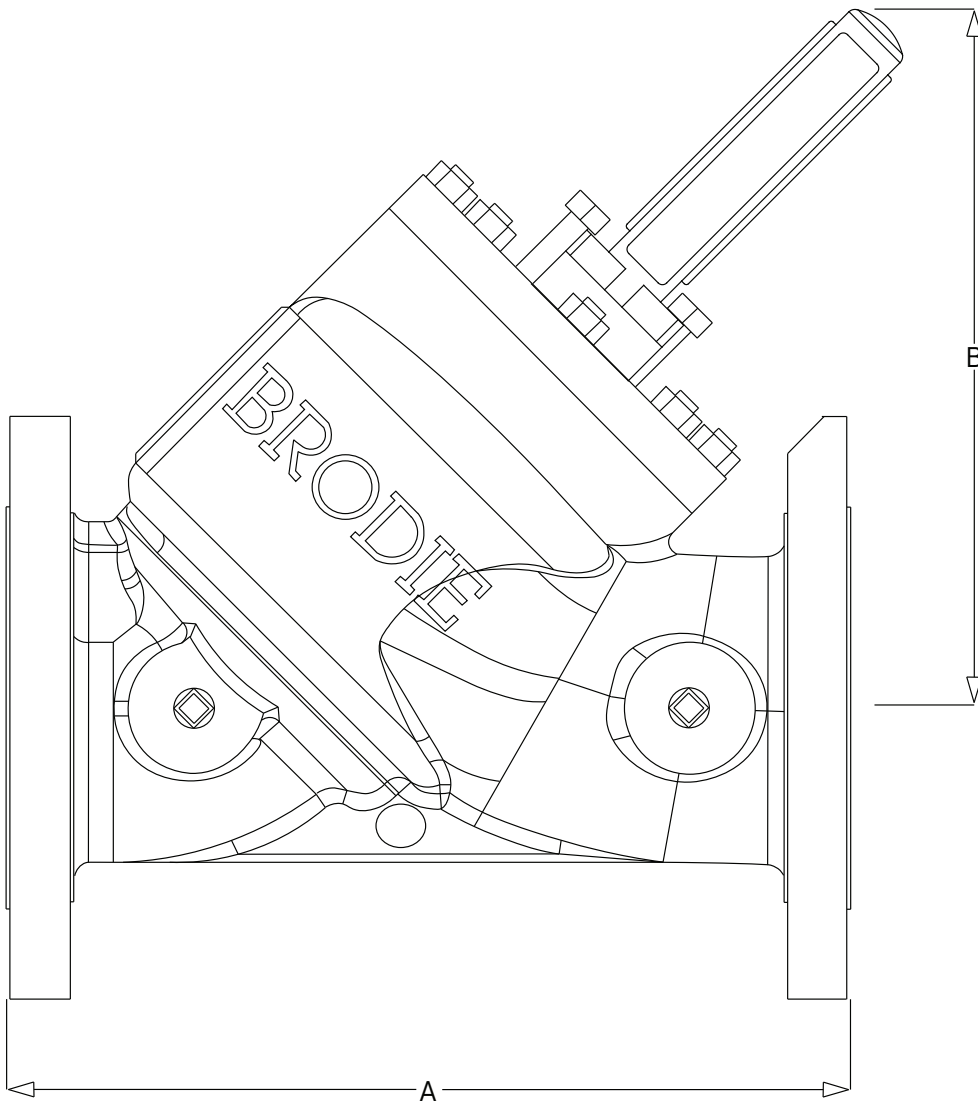

9 Installation and Operation

General

The following is a general outline for the proper operation, installation and start-up of any Brodie Control Valve.

9.1 Models BV02 and BV03, Check Valve

The Basic Function Model BV02 and BV03 Check Valves are designed to provide smooth shock-free opening and closure to prevent reverse flow.

Model BV02 is equipped with a manual needle valve to control opening/closing speed.

Model BV03 is supplied as a basic valve with no controls. It is utilized as a replacement for original equipment in applications where custom control is desired by the end user. As with all Brodie BV Valves it may be adapted for hydraulic, pneumatic or solenoid pilot control.

9.2 Models BV10 and BV11, On/Off Control Valve

Models BV10 and BV11 are solenoid operated valves designed for remote On/Off control applications. Model BV10 is normally closed, and Model BV11 is normally open, your application may require either N.O. or N.C. for fail-safe conditions.

The pilot valve is a fully balanced, two-way valve with integral manual override features. The external piping is fitted with a strainer on the pilot control line and a needle valve for controlling the speed of closure and for sensitivity control.

9.3 Model BV28, Power Cylinder Operated Control Valve

The Model BV28 is a power cylinder operated digital control valve designed to be used where minimum pressure drop is required, or for applications where it is not practical to use the flowing stream as the power medium to operate a valve. Because the main piston is controlled externally, and by reason of the 45° body design, pressure drop through these valves is extremely low.

Standard power cylinders are designed to operate on 30 psi (207 kPa) minimum for full stroke and are limited to a maximum pressure of 100 psi (689 kPa).

The valve is pilot operated on a balanced piston

principle, with a spring biased power cylinder operator. Spring loading of the power cylinder operator in the BV28 is such that the valve is normally closed.

The BV28 Digital Valve is electrically operated from presets or batch control devices. Energizing the solenoids opens the valves. By using presets, the valves can be automatically positioned for low flow start/stop, high flow, and no flow.

The solenoids control the position of the power cylinder by applying or venting the power source. An atmospheric vent prevents the mixing of line fluid with power cylinder operating medium.

9.3.1 Model BV28 Series Wiring Schematic

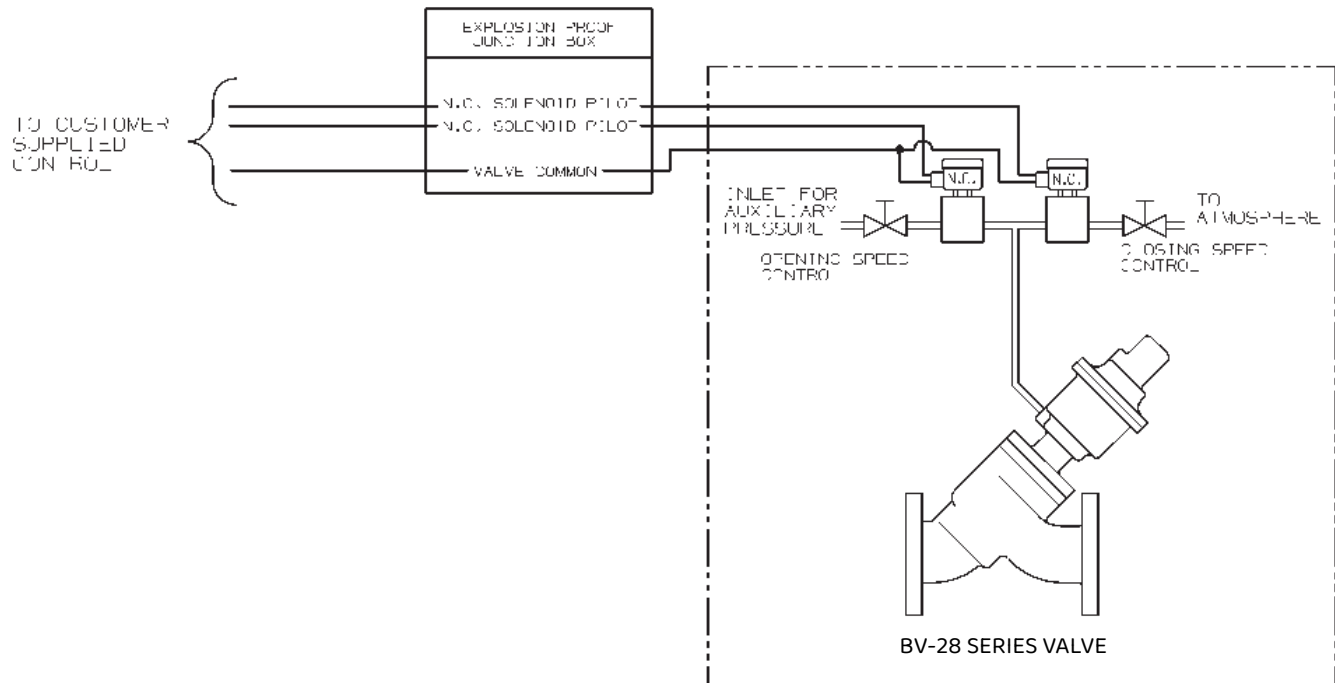

Figure 8-1 BV-20 Series Wiring Schematic

9.4 Model BV50, Pressure Reducing Valve

The Model BV50 Pressure Reducing Valve is designed for close regulation of downstream pressure. Constant downstream pressure is maintained within ± 2 psi (13.8 kPa) or better, regardless of variation in flowrate or upstream pressure.

The valve is controlled by a pressure reducing pilot which senses line pressure at a selected point and

throttles the valve to maintain a desired pressure at that point. If line pressure at the sense point exceeds the setting of the pilot, the pilot throttles the valve until the correct pressure level is reached. Conversely, if line pressure at the sense point falls below the setting of the pilot, the pilot throttles the valve again until the correct pressure level is reached.

9.5 Model BV54, Flow Limiting Valve

The Model BV54 Flow Limiting Valve controls maximum rate of flow to $\pm 2\%$ regardless of variations in the upstream or downstream pressure, and will operate on a differential as low as 5 psi (34.5 kPa).

The valve is pilot operated and operates on a balanced piston principle, spring biased to a closed position. Pressure differential overcomes the force

of the spring, causing the main valve to open and establish flow. The Rate of Flow (Flow Limiting) Valve is normally open and throttles towards a closed position on increasing differential pressure.

Although normally used to control the flow rate through a meter, the BV54 can be used for any application requiring accurate, dependable flow control.

9.6 Model BV60, Back Pressure/Relief Valve

The Model BV60 Back Pressure Control/Relief Valve is a normally closed, pilot operated valve. The valve is controlled by a back pressure pilot which senses line pressure at a selected point upstream of the valve and throttles the valve to maintain a desired minimum pressure at that point.

If line pressure at the sense point exceeds the setting of the pilot, the pilot throttles the valve open until the correct pressure level is reached. Conversely, if line pressure at the sense point falls below the setting of the pilot, the pilot throttles the valve closed until the correct pressure level is reached.

In the static condition, both the pilot and valve are closed. When the pump is activated, the initial pressure developed at the valve intake is applied to the top of the valve piston, keeping it tightly seated and preventing all flow. As pump discharge pressure rises, it soon exceeds the set point of the pilot, which then opens the valve to provide flow.

Once the valve has opened and continuous flow is established, the pilot monitors upstream pressure and compares it with the set point. If upstream pressure is greater than the set point, the pilot vents the pressure on top of the valve piston downstream and the valve opens wider to conduct more flow. If upstream pressure is less than the set point, however, the pilot applies additional pressure to the top of the valve piston, and the valve throttles closed to restrict flow. The valve will limit flow in this manner in order to maintain the required minimum back pressure. A needle valve is included as a sensitivity adjustment used to regulate the speed at which the valve opens and closes.

A constant back pressure is maintained within +/- 2 psi (13.8 kPa) of set point, regardless of variations in flow rate or upstream pressure. A minimum pressure differential across the valve of 15 psi (103 kPa) is required for it to fully open.

9.6.1 Model BV60, Recommended Installation Instructions

The following instructions are intended as a guide for installing the Model BV60 valve and should be carefully complied with if the valve is to operate as designed. Refer to Figures 8-2 and 8-3 for a typical installation diagram for item number.

1. If possible, the control valve should be installed within 25 feet of the point at which upstream line pressure is to be controlled. This distance limitation is due to the sense line which must be run to the pilot. Consult the factory if sense lines of greater length are required.
2. It is recommended that the control valve be installed between isolating valves. This will permit the system to remain operational while maintenance is being performed on the valve.
3. The product line must be completely free of all foreign material before the valve is bolted into

the line. This is very important and cannot be overstressed. If it is impractical to flush the line before installing the valve, the valve body may be bolted in place, and the cylinder assembly may then be removed per the disassembly instructions on the basic valve. In such a case, however, it will be necessary to install a temporary cover for sealing the opening left in the body by the removal of the cylinder. It will also be necessary to either disconnect or isolate the sense line if it is to be connected to the pilot. The possibility of foreign material flowing in to the sensing chamber of the pilot will thus be eliminated. (Flushing will not be necessary if the product line and liquid are positively known to be clean).

4. One 3/8" sense line is required between the pilot and the upstream point. This size line is a minimum requirement, however, and is based

on a maximum product viscosity of 500 SSU. A larger size sense line should be used if the viscosity of the product is in excess of 500 SSU. This sense line is mated with the lower connection of the pilot.

5. The inclusion of a pressure gauge in the valve

circuit is recommended. This gauge will permit upstream pressure to be monitored when installed at the location indicated on the valve schematic. It is very important that the gauge be installed at the upstream sense point since it must be monitored to properly adjust the valve. This gauge is not furnished by Brodie.

9.6.2 Model BV60, Adjustment and Startup Procedure

Refer to the typical installation for item locations, the valve is adjusted as outlined below. All isolation valves must be closed before adjustment can begin.

1. Bleed all of the air from the system. This is done by starting the pump (if a static head of 5 - 10 PSI is not present).
2. Slowly open upstream isolation valve, and loosen the external sense line connection at the pilot and at the top of the valve cylinder. Retighten the connection, close valve, and deactivate the pump when the line is free of air.
3. Turn the sensitivity adjustment counter-clockwise, 1/2 turn from closed if it is a needle valve only, or three turns from closed if it is a needle valve and strainer combination.
4. Turn the pilot adjustment stem counterclockwise until all spring tension is relieved. The valve will now open when nominal pump discharge pressure is sensed by the pilot.
5. Start the pump and slowly open the isolating valve upstream of the control valve (the bypass valve is never open under normal operating conditions. It is included in the circuit only to bypass the control valve when it is being repaired or maintained).
6. Partially open isolating valve downstream of

the valve and observe pressure gauge to determine when the valve begins controlling. This will be indicated by a drop in upstream pressure as the downstream isolation valve opens. When a pressure drop is observed on gauge, slowly turn the pilot adjustment screw clockwise until upstream pressure begins to rise.

7. Completely open downstream isolation valve. Upstream pressure should remain stable at the set point of the pilot. If the pressure is incorrect, turn the pilot adjustment screw clockwise to increase pressure and counter-clockwise to decrease pressure.
8. If pulsation occurs in the control valve, it may be eliminated by turning the sensitivity adjustment clockwise.

NOTE

The sensitivity adjustment may also be used to regulate the speed of valve response. By turning the sensitivity control clockwise, the opening speed of the valve will be increased, and the closing speed will be decreased. An opposite effect will be noted if the sensitivity control is turned counter-clockwise.

CAUTION

Never completely close the sensitivity adjustment. It should remain at least 1/4 turn open. If the sensitivity adjustment is fully closed, the valve will not control.

9.6.3 Model BV60, Typical Installation

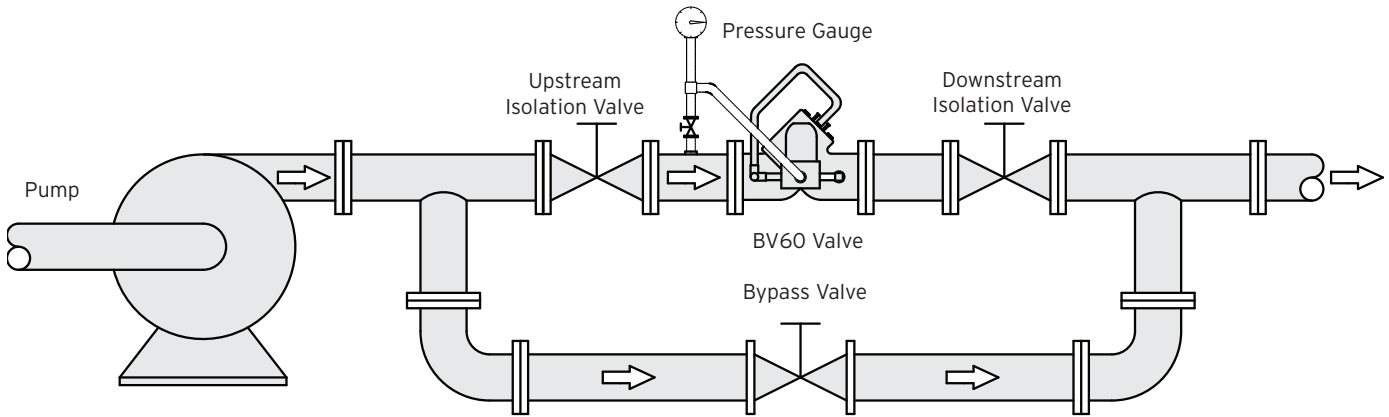

Figure 8-2 Back Pressure against a pump

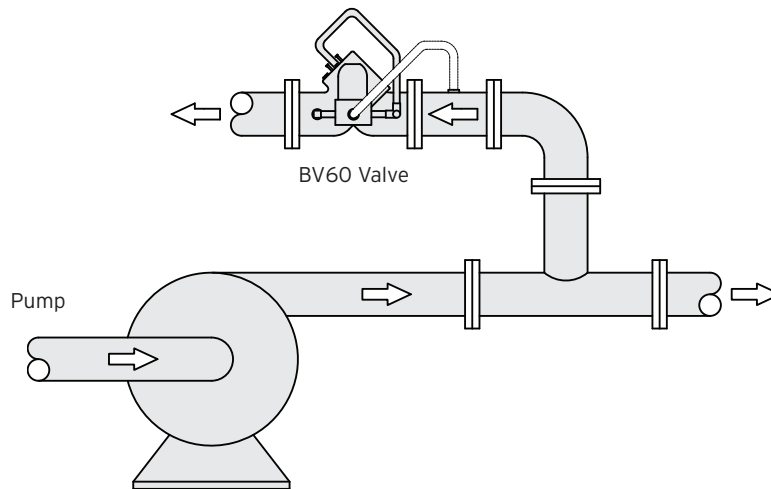

Figure 8-3 Pressure Relief/Pump Bypass

9.7 Model BV70, Differential Control Valve

The Model BV70 Differential Control Valve is a normally closed, regulating, or positioning, type valve designed for applications requiring valve closure on decreasing pressure differential.

Pressure differential overcomes the force of the spring, causing the main valve to open and establish flow. The pilot control varies the pressure on the spring side of the piston for position.

It does not require an outside power source to operate. A controlled pressure differential is maintained within $\pm 2\%$ regardless of variations in upstream or downstream pressure.

The pilots are balanced, single seated valves with large ports and will operate on a differential as low as 5 psi (34.5 kPa).

9.8 Model BV86, Two-Stage Mechanical Control Valve

The Model BV86 is normally used with a Positive Displacement Meter, or Mechanical Batch Preset Unit, to give close tolerance batch control and shock free closure.

Through the use of optional accessory pilots, mounted in series with the BV86 pilot, functions such as back pressure, pressure reducing, or rate of flow control can be obtained. No external power is needed - the valve is operated hydraulically by the flowing liquid being metered.

Operation is simple and trouble free - affording all the advantages of mechanical systems without the need for a separate flow limiting valve.

The valve is pilot operated on a balanced piston principle, spring biased to a closed position. Pres-

sure differential overcomes the force of the spring, causing the main valve to open and establish flow. The pilot control(s) vary the pressure on the spring side of the piston for a position. The Hydraulic pilot is mechanically attached to, and actuated by, the preset counter of the flowmeter and is hydraulically connected to the shut-off valve.

When the preset counter "start" button is depressed, the pilot opens to its full-open position and the main valve opens to high flow. As the preset counter engages its first stage trip, the pilot is partially closed, causing the main valve to throttle to a low flow position. Upon final trip of the preset counter, the mechanically actuated pilot is forced to a fully-closed position. This causes the hydraulic pressure across the main valve piston to be balanced, thus closing the valve.

9.9 Model BV88 Digital Control Valve

The Model BV88 Digital Control Valve is a solenoid operated device designed to provide precise flow rate control and batch delivery of liquid products. It is used in conjunction with an electronic batch control device.

The BV88 valve automatically controls low flow start-up, high flow rate control, low flow shutdown, and final shut-off. It also provides for maximum flow meter accuracy by maintaining a constant

flow rate in applications with varying line pressure. The BV88 features an external pilot control loop that consists of a normally open solenoid pilot, a normally closed solenoid pilot, strainer and opening/closing speed controls. The pilot controls vary the pressure on the spring side of the piston for position. Spring loaded Teflon cup-seats are utilized on the main body piston and low swell Nitrile O-rings in static positions.

9.9.1 Model BV88, Recommended Installation Instructions

As with all control valves, it is most important that proper installation be accomplished if the valve is to operate as designed. Preliminary setup should include the following steps:

1. Evaluate the metering system in the process line to determine that criteria pertinent to digital control is met.

A. Minimum meter K-factor: 20 pulses/unit

B. Minimum meter pulse frequency (low flow): 50 Hz

C. Minimum opening time (shut-off to full open): 1.5 seconds

D. Minimum closing time (full open to shut off): 1.5 seconds

-
2. Reference engineering drawings for proper in-line sequence for all components.
 3. Check valve position. The inlet flange has been marked and is to be in the upstream position.
 4. Verify all electrical connections against wiring diagrams and unit specifications.

WARNING

It is recommended that the external pump be turned to the OFF position when performing any

electrical wiring installation and until initial control valve adjustments are made.

5. Flush the line of any and all contaminants.
6. Bleed as much air as possible from the system before start up.

NOTE

Upon completion of the preliminary installation of the Digital Control Valve a Start-Up Adjustment Procedure must be administered.

9.9.2 Model BV88, Adjustment and Startup Procedure

The following information is provided as a guideline for proper set-up and operation of the Brodie Model BV88 Digital Valve when used with an electronic preset.

1. Activate or verify that the digital valve control function is properly programmed. If the preset is not programmed for digital control, poor flow rate and quantity control will result.
2. Control Parameters such as high and low flow error, valve response time, flow rates, and final stop quantities are functions of system hydraulics and should be set based on customer requirements with consideration given to system performance.
3. Initial recommended setting for the opening/closing speed needle valves are shown in the chart below. The opening speed needle valve is located on the downstream side of the valve and the closing speed needle valve is located on the upstream side of the valve. The valve will likely require fine tuning depending upon system hydraulics and type of preset being used in order to provide precise flow rate control while minimizing surge pressures during operation. The valve should allow for rapid closure in the event of an emergency shutdown without introducing surge pressures due to system hydraulics.
4. To finalize the needle valve settings, initiate a small batch delivery. Observe the flow-rate during low flow start, high flow and low flow stop. Adjust the needle valves as required to minimize so-lenoid actuations. Typically, the so-lenoids should actuate 3 or 4 times in order for the flow rate to stabilize during flow transitions - start to low flow, low flow to high flow, and high flow to low flow stop. Excessive actuations increase wear and decrease lifespan of valve components.
5. To allow for faster valve opening, turn the downstream needle valve counter-clockwise in 1/4 turn increments until the desired opening speed is achieved. To allow for slower valve opening turn the downstream needle valve clockwise in 1/4 turn increments until the desired opening speed is achieved. The needle valve should never be closed during normal operation.
6. To allow for faster valve closure, turn the upstream needle valve counter-clockwise in 1/4 turn increments until the desired valve closure is achieved. To allow for slower valve closure turn the upstream needle valve clockwise in 1/4 turn increments until the desired closing speed is achieved. The needle valve should never be completely closed during normal operation.

7. The flow profile error limits also affect the number of solenoid actuations. The error limits should be set to the maximum limits required to keep the flowrate in control. The minimum error limit is a function of meter pulse frequency; the larger the k-factor the better. As different electronic presets have different frequency ranges, a general frequency value is a minimum of 50 Hz at the low flow rate.

Line size inches	Typical opening speed adjustment (turns open)	Typical opening time (Shutoff to low flow start) seconds	Typical opening time (Low flow start to high flow) seconds	Typical closing speed adjustment (turns open)	Typical closing Time (Full flow to Shutoff) seconds
2	0.5	2	2	1	2
3	1	2	2	1.5	2
4	1	3	3	1.5	3
6	2	3	4	3	4
8	3	4	5	4	5

NOTE: The above are recommended initial needle valve settings and can vary depending upon the viscosity/density of the fluid, system hydraulics, and preset being used. The typical opening and closing speeds can vary and will depend upon final needle valve settings, system pressure, and product viscosity/density.

9.10 Model BV89, Two-Stage Control Valve

The Model BV89 Control Valve is a normally closed, two-stage electrical valve designed for precise, accurate shut-off of petroleum products. In applications such as petroleum loading racks where product delivery is predetermined and metered, the valve reduces flowrate before final shut-off to minimize pressure surge and line shock. Two-stage opening is also available.

Electrically operated solenoid pilots position the valve piston by increasing or decreasing hydraulic pressure on the top of the piston as dictated by sequencing switches. When pressure on both sides of the valve piston is equal, the main valve spring acts as a differential force and closes the valve.

When the pressure against the bottom of the piston exceeds the pressure (plus the force of

the spring) exerted against the top of the piston, spring pressure is overcome and the valve is opened.

The control valve is designed to close in two distinct stages. As the preset counter reaches the first stage of shut-off, the preset trips the sequence switches to place the valve in the first stage (low flow) shut-off position. The first stage closure reduces the flow rate through the valve to approximately 10 to 20 percent of the rated capacity of the meter. The preset trips the sequencing switches again and the valve closes.

The pilots are balanced, single seated valves with large ports and will operate on a differential as low as 5 psi (34.5 kPa).

10 Maintenance

General

The following chapter explains the basic disassembly of the bare valve. Please refer to pilot documentation for specific instructions on the maintenance and disassembly of the pilot. The basic processes and techniques explained in this chapter apply to all Brodie BV Series Control Valves regardless of size.



10.1 Disassembly of the Cylinder Assembly with Valve Position Indicator

The following tools will be needed to disassemble and reassemble the valve:

- Socket Wrench
- Adjustable Wrench
- T Handle or Extended Allen Wrench
- Screwdriver
- Rubber Hammer
- Arbor Press

WARNING:

The cylinder head is bolted to a spring loaded cylinder assembly and will require caution when performing any disassembly procedure. Failure to comply with recommended practice could result in serious personal injury and/or damage to the equipment. Service should be performed only by trained and qualified service personnel.

WARNING:

No attempt should be made to service this valve without referring to the pictorial examples in this manual.

NOTE:

All item numbers can be found in Chapter 12, Parts Lists. Reference the section appropriate for your model equipment. Section numbers are given where appropriate.

1. Remove two screws (Item 17) and lockwashers (Item 18) from indicator guard (Item 20).

2. Grasp indicator guard and remove from valve assembly along with microswitch (Section 12.6 and 12.7), screw, washer, mounting plate, screw, and washer.
3. Remove O-ring (Item 23), upper bearing (Item 19), trip dog (Section 12.6 and 12.7), and set screw (Section 12.6 and 12.7).
4. Remove nuts (Item 3, Section 12.1) holding cylinder head (Item 2, Section 12.1) in valve body (Item 1, Section 12.1).
5. Alternately tighten each jack screw (Item 5, Figure 12.1.1) one half turn until cylinder assembly is free of valve body. (Figure 9-1)

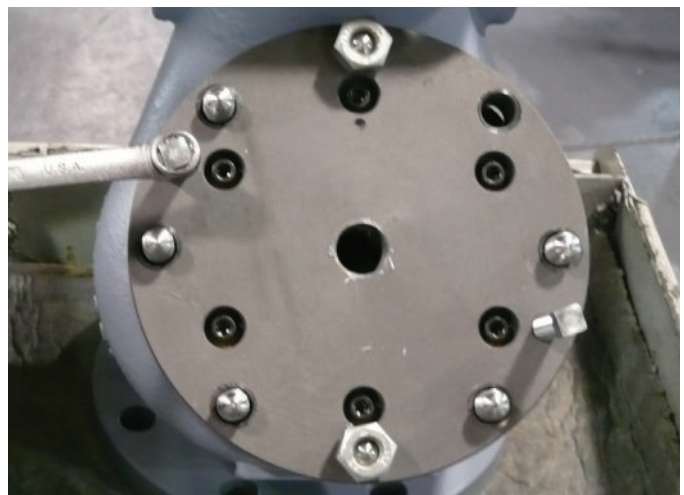

Figure 9-1 Alternately Tighten Jack Screw

CAUTION:

These screws should be tightened evenly to prevent damaging the cylinder O-rings and binding the cylinder assembly.

- Using both hands pull the cylinder assembly straight out along its axis. Completely remove the two jack screws. (Figure 9-2)

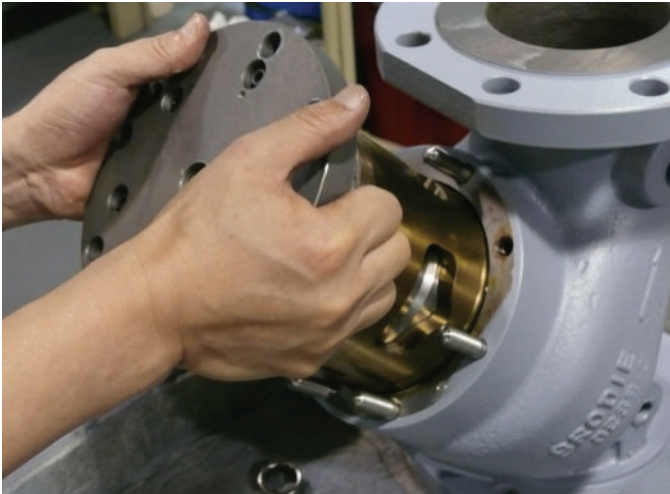

Figure 9-2 Remove Cylinder Assembly From Valve Body

- With extreme caution, depress piston against spring until ports are cleared. An arbor press may be necessary to depress piston depending on pressure exerted by main valve spring.
- Block piston in open position by inserting suitable wedges through port openings. (Figure 9-3)
- Spirolox retaining ring (Item 6), seal ring (Item 5) and O-ring (Item 9) may now be removed from cylinder (Item 2). (Figure 9-4, 9-5, and 9-6)

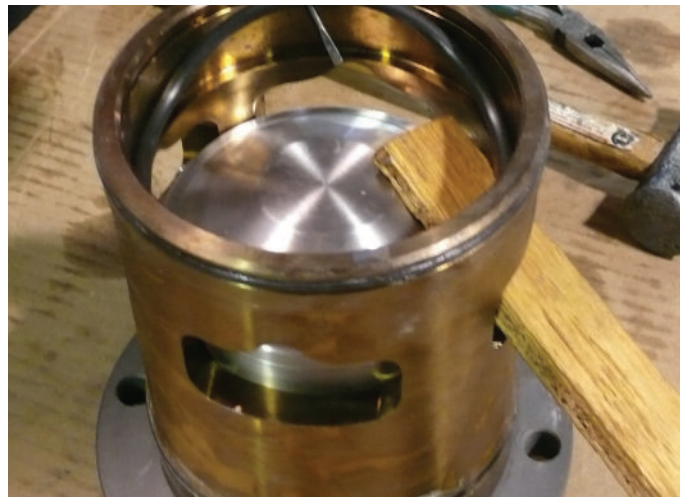

Figure 9-3 Block Piston In Open Position



Figure 9-4 Spirolox Retaining Ring



Figure 9-5 Seal Ring



Figure 9-6 O-ring

10. With piston wedges removed, spring (Item 3) can be removed from cylinder. (Figures 9-7, and 9-8)

CAUTION:

Remove piston blocks with caution, as spring exerts considerable force against piston.



Figure 9-8 Removing Spring From Cylinder

11. Remove indicator stem (Item 21) with pin (Item 15) and piston cap (Item 13) as an assembly after removing three screws (Item 18 on 2", Item 14 or 3", 4", and 6") from piston cap. The indicator stem may be removed from the piston cap by driving the roll pin out of the piston cap.

12. Remove O-rings (Item 12).

13. Remove indicator guard adaptor (Item 16) from cylinder head by turning counter-clockwise.

14. Remove cylinder from cylinder head by removing screws (Item 7) and O-rings (Item 10).



Figure 9-7 Removing Spring From Cylinder

10.2 Reassembly of Cylinder Assembly With Valve Position Indicator

To prevent nicking of O-rings during reassembly coat all O-rings with a light grease or any high-grade lubricant. All O-rings should be carefully examined for cuts, nicks or distortion during reassembly and replaced if found to be defective.

1. Install O-rings (Item 10) on cylinder head (Item 1).
2. Install piston cap (Item 13) on indicator stem (Item 21) with roll pin (Item 15) and place O-ring (Item 12) in the nose of the piston (Item 4) and secure with three screws (Item 26 on 2", Item 14 on 3", 4" , and 6")
3. Install two O-rings (Item 11) on cylinder (Item 2).
4. Install O-ring (Item 8) on piston.
5. Install spring (Item 3) and piston in cylinder and block piston in the open position (may require an arbor press). (Figure 9-3)
6. Insert O-ring (Item 9) and sealing ring (Item 5) in cylinder.
7. Install sprilox retaining ring (Item 6) in cylinder, start one end in groove and gradually wind into place. When all of the retaining ring is in the groove use a punch applied to one end to completely seat the retaining ring.
8. Using caution, remove piston blocks.
9. Install cylinder assembly (Item 2, Section 12.1) in valve body and secure with nuts (Item 3, Section 12.1).
10. Install indicator guard adaptor (Item 16) on cylinder head by turning clockwise.
11. Install O-ring (Item 23) on upper bearing (Item 19), place bearing and trip dog (Section 12.6 and 12.7) on indicator stem.
12. Place indicator guard (Item 20) on indicator guard adaptor and secure with two lockwashers (Item 18) and screws (Item 17).
13. Replace two jack screws (Item 5, Section 12.1).

CAUTION:

With extreme care, depress piston against spring until rectangular ports are cleared. An arbor press may be necessary to depress the piston depending on the pressure exerted by the main valve spring. Block piston in open position by inserting suitable wedges through port openings, using care not to damage O-rings.

10.3 Disassembly of Cylinder Assembly without Valve Position Indicator

WARNING:

No attempt should be made to service this valve without referring to the pictorial examples in this manual. Failure to comply with this procedure can result in serious personal injury and/or damage to the equipment.

1. Remove nuts (Item 3).
2. The entire cylinder assembly, including seat ring, may now be removed as a unit by utilizing the two jack screws (Item, 5, Section 12.1) provided in the cylinder head. (Figure 9-1).
3. Using both hands pull the cylinder assembly straight out along its axis. Completely remove the two jack screws. (Figure 9-2)

CAUTION:

These screws should be tightened evenly to prevent damaging the cylinder O-rings and binding the cylinder assembly.

-
4. With extreme caution, depress piston against spring until ports are cleared. An arbor press may be necessary to depress piston depending on pressure exerted by main valve spring.
 5. Block piston in open position by inserting suitable wedges through port openings. (Figure 9-3)
 6. Spirolox retaining ring (Item 6), seal ring (Item 5) and O-ring (Item 9) may now be removed from cylinder head (Item 2). (Figure 9-4, 9-5, and 9-6)
 7. With piston wedges removed, spring (Item 3) can be removed from cylinder. (Figures 9-7, and 9-8)

CAUTION:
Remove piston blocks with caution, as spring exerts considerable force against piston.

8. Remove cylinder from cylinder head by removing screws (Item 7) and O-rings (Item 10).

10.4 Reassembly of Cylinder Assembly without Valve Position Indicator

To prevent nicking of O-rings during reassembly coat all O-rings with a light grease or any high-grade lubricant. All O-rings should be carefully examined for cuts, nicks or distortion during reassembly and replaced if found to be defective.

press may be necessary to depress the piston, depending on the pressure exerted by the main valve spring. Block piston in open position by inserting suitable wedges through port openings. Be careful not to damage O-rings.

1. Install O-rings (Item 10) on cylinder head (Item 1).
2. Install piston cap (Item 13) on indicator stem (Item 21) with roll pin (Item 15) and place O-ring (Item 12) in the nose of the piston (Item 4) and secure with three screws (Item 26 on 2", Item 14 on 3", 4" , and 6")
3. Install two O-rings (Item 11) on cylinder (Item 2).
4. Install O-ring (Item 8) on piston.
5. Install spring (Item 3) and piston in cylinder and block piston in the open position (may require an arbor press). (Figure 9-3)
6. Insert O-ring (Item 9) and sealing ring (Item 5) in cylinder.
7. Install spriolox retaining ring (Item 6) in cylinder, start one end in groove and gradually wind into place. When all of the retaining ring is in the groove, use a punch applied to one end to completely seat the retaining ring.
8. Using caution, remove piston blocks.
9. Install cylinder assembly (Item 2, Section 12.1) in valve body and secure with nuts (Item 3, Section 12.1).
10. Replace two jack screws (Item 5, Section 12.1).

CAUTION:
With extreme care, depress piston against spring until rectangular ports are cleared. An arbor

10.5 Aggressive Products Cylinder Disassembly

WARNING:

The Cylinder Head is bolted to a spring loaded cylinder assembly and will require caution when performing any disassembly procedure. Failure to comply with recommended practice could result in serious personal injury and/or damage to the equipment. Service should be performed only by trained and qualified service personnel.

1. Position the cylinder assembly with the cylinder head (Item 1) up. Larger units may require the use of a spindle or arbor press to facilitate removal of the piston assembly in which case the arbor should be resting against the cylinder head.
2. Carefully loosen the screws (Item 7) which hold the cylinder head in place. Alternate to opposite sides to equalize release of spring tension on the cylinder head.
3. Using extreme caution, hold the cylinder head firmly against the cylinder assembly and remove the retaining screws.
4. Lift off the cylinder head and retain accompanying O-rings for reassembly.
5. If an indicator is being used, care should be taken to avoid bending or damaging the indicator stem (Item 21) in this operation.

NOTE:

It is not necessary to remove the indicator guard (Item 20) or other component parts of the indicator at this time; however the indicator stem should be wiped clean of any residue or foreign material that may have gathered on its surface. This will protect the O-Ring (Item 23) from unnecessary abrasion upon removal of the indicator stem.

6. The spring, piston, indicator stem assembly (if used), and cylinder may be removed at this time by pushing from the bottom of the unit.

NOTE:

Do not attempt to remove the piston through the seat area. Removal through the seat area will destroy the spring loaded Teflon cup seals.

7. Inspect all O-rings (cylinder, piston, cylinder head and indicator), and cup-seals for nicks, damage or wear, and replace as required.
8. The cylinder and piston may be cleaned to remove foreign materials or residue that may impede proper operation. Care should be taken not to damage the piston seat radius or seals.

10.6 Cup-Seal Replacement on Existing "AP" Option Piston

If your Valve is being modified to accommodate applications requiring the use of aggressive products used in petroleum blending operations the following procedures should be followed in retrofitting your valve.

To replace existing standard cylinder assemblies with the current AP Option:

1. Remove the original cylinder assembly as shown in Section 9.1 or 9.3. The cylinder assembly will be supplied from the factory with or

without an indicator (specified on order).

2. Clean and inspect O-ring sealing surfaces in the main valve body. Apply a lightweight lubricant to these surfaces before installing the new cylinder assembly.
3. Lower the new cylinder assembly and cylinder head into the valve body. Align the bolt holes in the cylinder head with the studs in the main valve body.

4. Fasten the cylinder head into position using retaining nuts. Tighten nuts, alternating to opposite sides, to assure a uniform seat.
5. Return all tubing and/or valve accessories to their original position.

To upgrade existing valves having the “AP” option the following parts have been supplied as a separate kit. (Reference Section 12.1, 12.2, and 12.3 for complete valve part numbers):

1. Follow procedures described in Sections 9.1 and 9.3 for general disassembly and Section 9.5 for Aggressive Products Cylinder disassembly.
2. Replace O-rings and install gasket, stat-o-seal and washers as required.
3. Complete cylinder assembly by installing piston and all component parts through the top of the cylinder housing.

NOTE:

Do not attempt to install the piston through the seat area. Attempts to assemble through the seat area will destroy the spring loaded teflon cup-seals.

4. Secure cylinder assembly to cylinder head using hand pressure or arbor press for ease of installation.
5. Lower the new cylinder assembly and cylinder head into the valve body. Align the bolts in the cylinder head with the studs in the main valve body.
6. Fasten the cylinder head into position using retaining nuts. Tighten nuts, alternating to opposite sides, to assure a uniform seat.
7. Return all tubing and/or valve accessories to their original position.

10.7 Torque Specifications for Cylinder Head Bolts (ft/lb.)

Size (All Models)	150 lb. ANSI	300 lb. ANSI	600lb. ANSI
2"	22	26	77
3"	36	49	68
4"	36	46	136
6"	37	67	250
8"	170	211	387
12"	403	496	700

10.8 Disassembly of Model BV28 Series Power Cylinder

WARNING:

No attempt should be made to service this valve without referring to the pictorial examples in this manual. Failure to comply with this procedure can result in serious personal injury and/or damage to the equipment.

1. Remove 4 bolts (Item 35) from power cylinder motor cover (Item 28). (Figure 9-9)

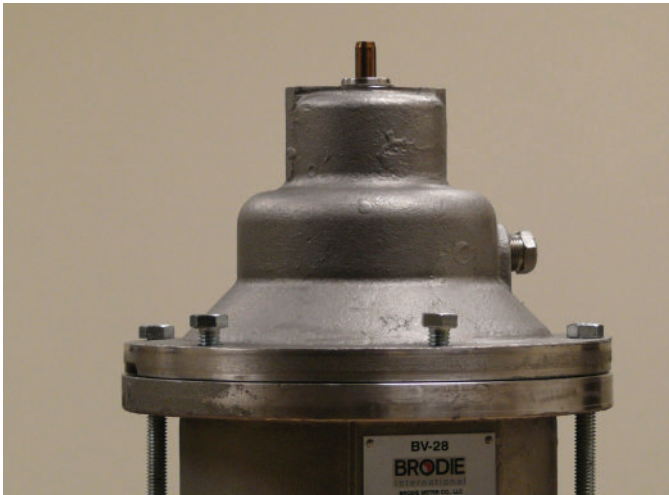

Figure 9-9 Power Cylinder Motor Cover

2. Loosen two bolts (Item 36) in even increments to remove all spring compression (Item 23). (Figure 9-10)

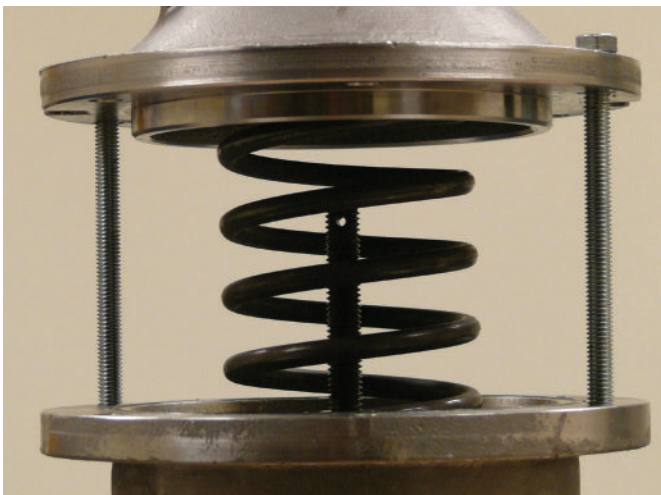

Figure 9-10 Remove Spring Compression

3. With all of the spring compression removed, remove the bolts from the assembly.
4. Carefully remove motor cover.
5. Remove the spring.
6. Remove spirol pin (Item 27) and indicator shaft (Item 22).
7. Remove retaining ring (Item 32) and indicator gland (Item 29) from cover. (Figure 9-11)

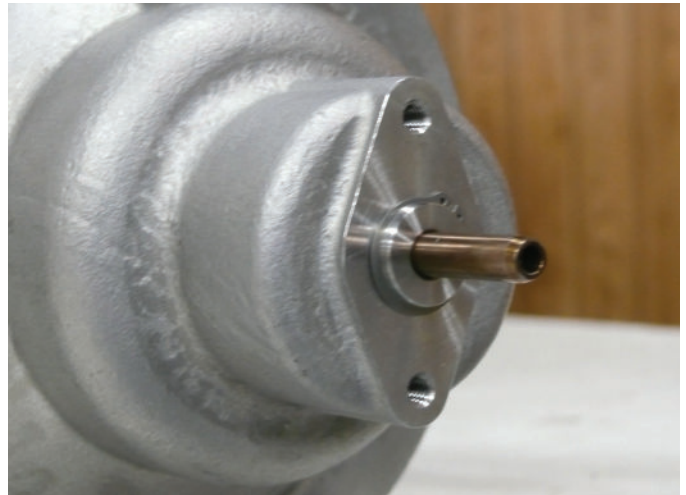

Figure 9-11 Remove Retaining Ring

8. Tighten jack screws (Item 37) to remove motor and cylinder assembly from the main valve body. (Figure 9-12)



Figure 9-12 Remove Power Cylinder Assembly from Main Valve Body

9. Remove jack screws from cylinder head.
10. Hold the shaft (Item 1) by the flats on the threaded end being careful not to damage the threads.
11. Remove nut (Item 26), lockwasher (Item 25) and flat washer (Item 24). (Figure 9-13)



Figure 9-13 Power Cylinder Shaft

12. Remove piston (Item 16) and bushing (Item 17). (Figure 9-14)



Figure 9-14 Remove Piston from Power Cylinder Assembly

13. Remove bolts (Item 38) and remove the motor housing (Item 21).

NOTE:

If the upper gland (Item 19) moves with the housing use caution when pulling the parts over the threaded portion of the shaft so the inner seal of the gland is not damaged. If the gland separates from the housing carefully remove the gland, using caution, so the inner seal of the gland is not damaged.

14. Carefully remove the lower gland (Item 20) and the O-ring (Item 15) over the threaded portion of the shaft, using caution so the inner seal of the gland is not damaged.
15. Remove socket head screws (Item 10) to separate valve cylinder from the cylinder head (Item 7). (Figure 9-15)

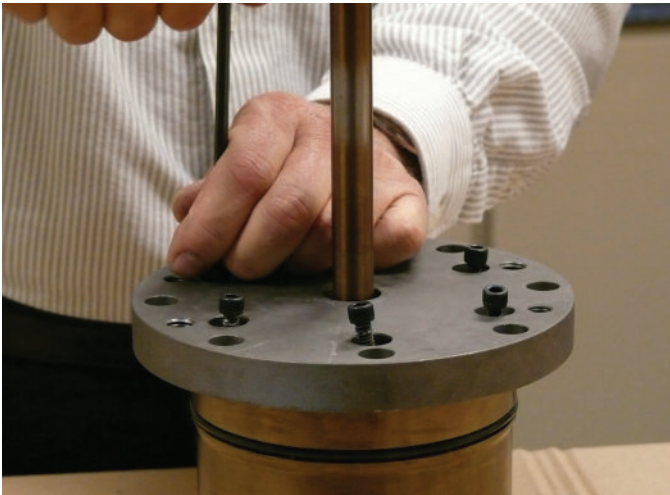

Figure 9-15 Separate Valve Cylinder from Cylinder Head

16. Remove cylinder head.
17. Remove piston and shaft assembly from the valve cylinder (removing through the top of the valve cylinder). (Figure 9-16)



Figure 9-16 Remove Piston and Shaft Assembly

18. Remove retaining ring (Item 9), seal ring (Item 8) and O-ring (Item 12) from the valve cylinder.

CAUTION:

Use care not to damage the the piston or shaft.

19. Remove spirol pin (Item 5) and lifting collar (Item 3) from shaft. (Figure 9-17)

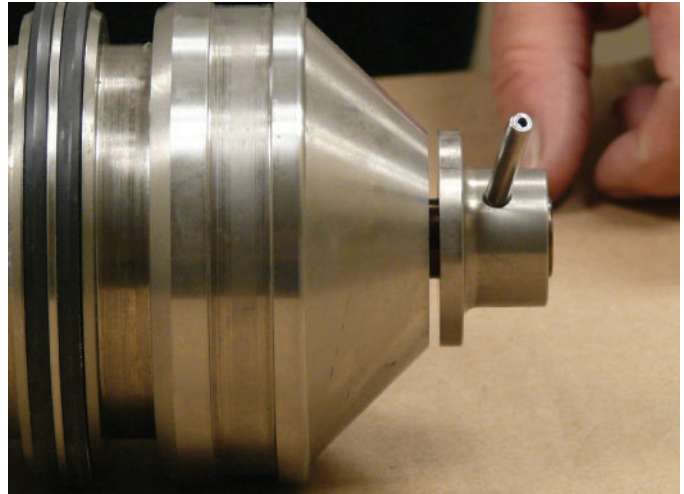

Figure 9-17 Spirol Pin and Lifting Collar

20. Remove piston (Item 2) from shaft.
21. Remove O-ring (Item 4) from shaft.
22. Remove piston seal(s) (Item 33) from shaft.

9.9 Model BV28 Series Power Cylinder Shaft Assembly

WARNING:

Improper assembly may result in improper operation of the product and may result in serious personal injury or death.

NOTE:

All parts must be inspected and cleaned before assembly. All O-rings and seals must be completely coated with Silicone Lubricant Grease, i.e. Parker O Lube or equivalent high-grade lubricant.

When installing O-rings, extra care is needed to prevent damage. The O-rings must be carefully worked in to place and not forced.

Perma-Lok screw locking compound (LM113), or equivalent, must be used when specified.

Reference Section 12.5 for assembly.

1. Carefully remove spirol pin (Item 4). Slide back O-ring sleeve (Item 2) on shaft. (Figure 9-18)

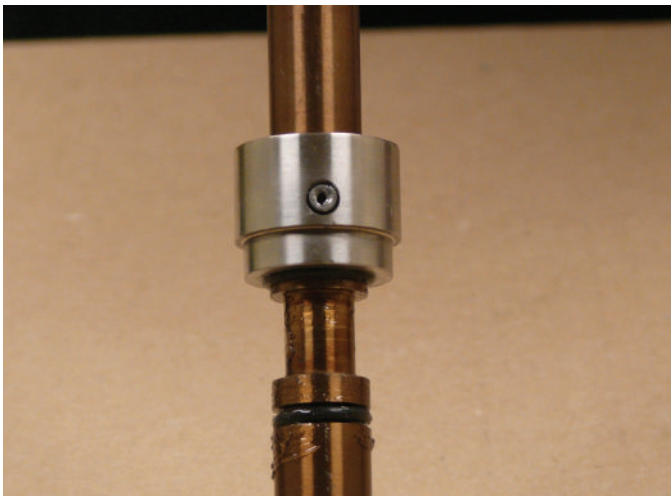

Figure 9-18 O-ring Sleeve and Spirol Pin

2. Remove O-ring (Item 3) from shaft assembly.

3. Place O-rings (Items 3 and 4) on shaft. Slide O-ring sleeve forward and align spirol pin hole. (Figure 9-19)

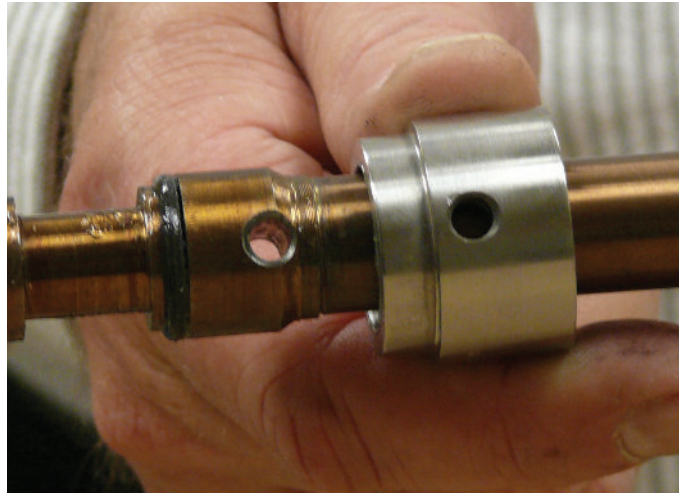

Figure 9-19 Align Spirol Pin Hole on O-ring Sleeve with Matching Hole on Shaft

4. Press spirol pin flush with the surface of O-ring sleeve. (Figure 9-20)

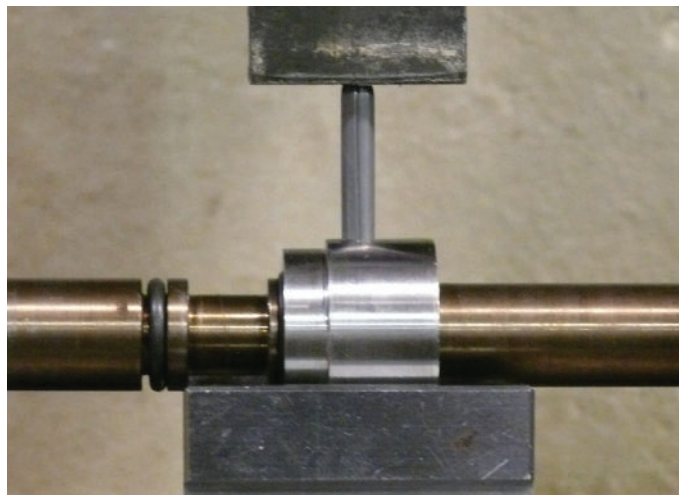

Figure 9-20 Press Spirol Pin

9.10 Model BV28 Series Power Cylinder Valve Assembly

There are different methods to assembling the BV28 cylinder and motor housing assembly. One method is to assemble the power cylinder assembly and install the complete unit on to the main valve body. Another method is to install the lower cylinder assembly in the valve body and assemble the motor assembly with the cylinder in place. Either method is acceptable and depends on the availability of proper tooling and manpower.

Refer to Figures 9-21 and 9-22 for seal options.



Figure 9-21 Teflon Seal Option



Figure 9-22 O-ring Seal Option

1. Place seal(s) (Item 12) on piston (Item 2).

2. Lubricate front portion of shaft and carefully slide piston into place. (Figure 9-23)

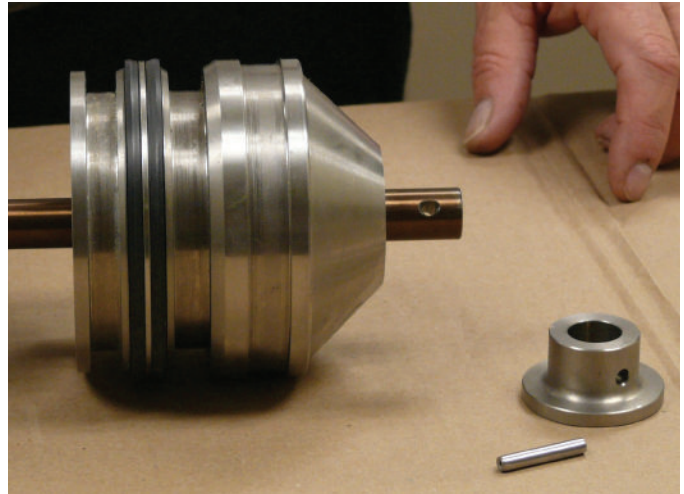

Figure 9-23 Slide Piston onto Shaft

3. Install lifting collar (Item 3) onto shaft and align with spiro pin hole.

4. Press spiro pin (Item 5) flush with outer surface of lifting collar. (Figures 9-24 and 9-25).

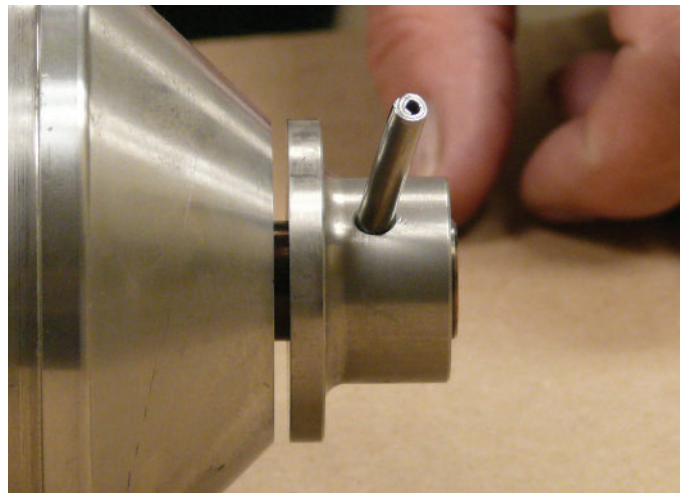

Figure 9-24 Press Spiro Pin

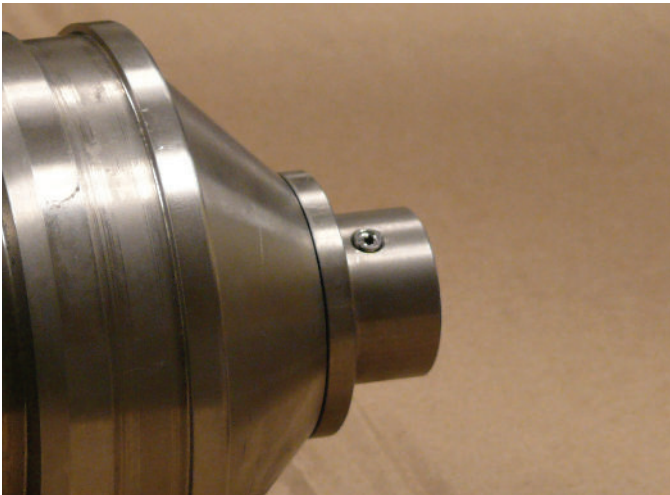

Figure 9-25 Press Spirol Pin



Figure 9-27 Install Retaining Ring

5. Replace two valve cylinder O-rings (Item 11).
6. Install O-ring (Item 12) into bottom end on valve cylinder.
7. Install seal ring (Item 8). (Figure 9-26)

9. Lubricate the chamfered surface of the valve cylinder.
10. Install shaft and piston into valve cylinder. Extra care should be taken so the seal will not buckle during installation. (Figure 9-28)



Figure 9-26 Install Seal Ring



Figure 9-28 Install Shaft and Piston Assembly in Valve Cylinder

8. Install retaining ring (Item 9). (Figure 9-27)

11. Install O-ring (Item 14) on cylinder head (Item 7). (Figure 9-30)

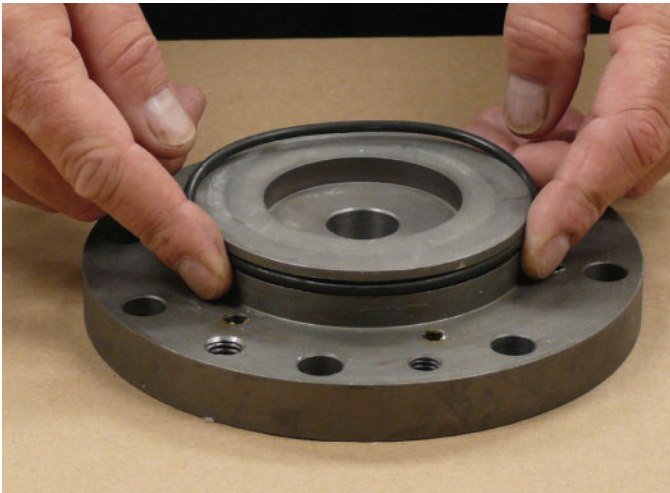

Figure 9-30 Install O-ring on Cylinder Head

12. Install cylinder head on valve cylinder. Align cylinder head with valve cylinder by orienting the alignment mark to the bottom of the cylinder. (Figure 9-31)

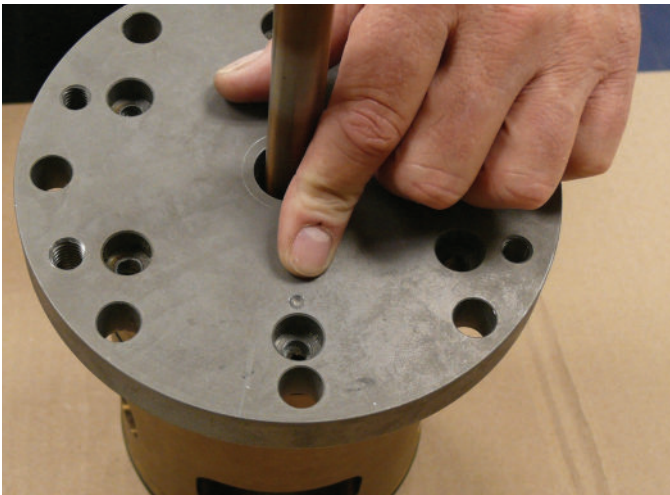

Figure 9-31 Alignment of Cylinder Head on Valve Cylinder

13. Install socket head cap screws (Item 10) using locking compound and torque to 10-14 ft/lbs.
14. Install cylinder assembly into valve body.
15. Replace inside O-ring (Item 44) of lower gland (Item 20) and O-ring (Item 15). Install lower gland over shaft and locate in cylinder head. Use extra care to avoid damage to inner O-ring and inner seal when installing over threads.

16. Replace inside O-ring (Item 44) of upper gland (Item 19) and outer O-ring (Item 31). Install upper gland over shaft (smaller O.D. first) and slide to touch lower gland. Use extra care to avoid damage to inner O-ring and inner seal when installing over threads.
17. Install motor housing (Item 21) and bolt on to cylinder assembly using hex head bolts (Item 38), use screw locking compound and torque to 58-61 ft/lbs. (Figure 9-32)



Figure 9-32 Install Motor Housing

18. Install hex nuts (Item 41) to secure cylinder assembly and motor housing to the valve body, use thread locking compound and torque to 23-30 ft/lbs.
19. Install jack screws (Item 37) in cylinder head (Item 7). Do not tighten jack screws with a wrench, these are for disassembly only.
20. Replace inner O-ring (Item 43) and O-ring (Item 18) on motor piston bushing (Item 17) and install in motor piston (Item 16). (Figure 9-33)

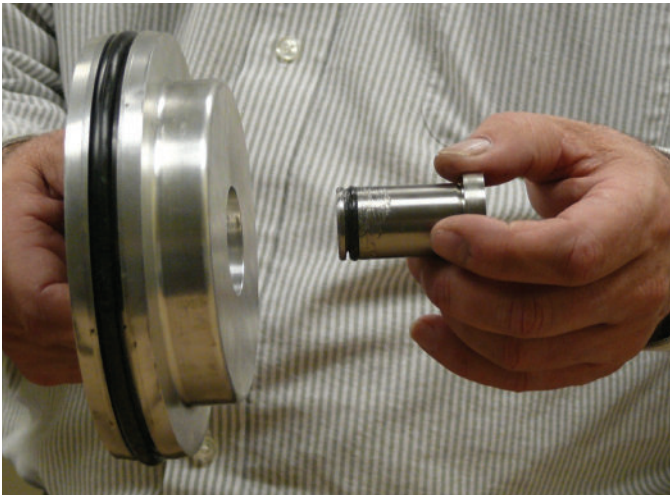

Figure 9-33 Install Motor Piston Bushing

21. Replace O-ring (Item 33) on motor piston.
22. Lubricate inside diameter of motor piston bushing and the inner diameter of motor housing (Item 21). Slide piston over shaft and into housing body. (Figure 9-34)



Figure 9-34 Install Motor Piston over Shaft

23. Install flat washer (Item 24) and lockwasher (Item 25) over shaft.
24. Install hex nut (Item 26) and tighten.

NOTE:

The shaft will need to be held by the flats on the end to tighten nut until the lockwasher is completely flat.

25. Install indicator shaft (Item 22) by aligning with holes on the cylinder shaft and installing spirol pin (Item 27) through the hole until pin is flush with the outside of the indicator shaft.
26. Replace inner O-ring (Item 45) on indicator gland (Item 29) and outer O-ring (Item 30).
27. Install indicator gland into housing cover (Item 28) and secure with retaining ring (Item 32). (Figure 9-35)

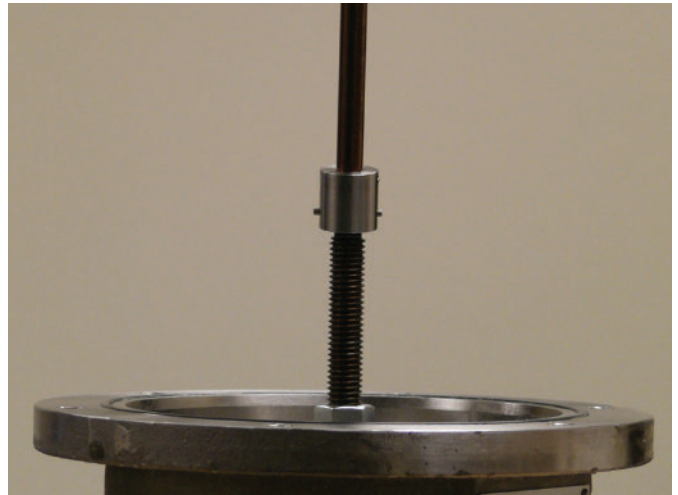

Figure 9-35 Install Indicator Gland

28. Lubricate the outer diameter of the indicator shaft.
29. Replace housing O-ring (Item 34).
30. Place spring (Item 23) into housing and locate flush with inner surface of motor piston. (Figure 9-36)



Figure 9-36 Install Spring in Housing

31. Install housing cover over indicator shaft and align so spring locates on inside diameter of housing cover.
32. Install hex head bolts (Item 36) through housing cover and thread into motor housing. (Figure 9-37)

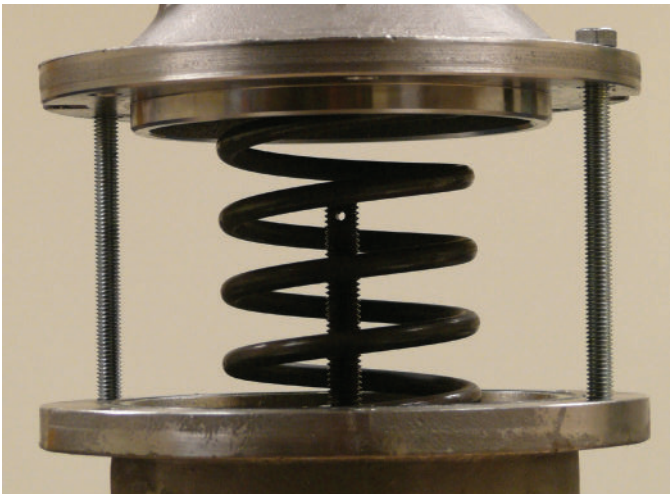

Figure 9-37 Thread Hex Head Bolts into Motor Housing

NOTE:

Hex head bolts must be located 180 degrees from each other and the threaded port in the housing cover must be aligned with the threaded port in the motor housing.

WARNING:

Tightening bolts will compress the spring and extra caution must be taken to avoid injury.

33. Tighten bolts in even increments to compress the spring until tight. Stem shaft (Item 22) must be aligned to the inside diameter of the indicator gland. A long dowel pin or hex wrench may be inserted through the indicator gland and into the hole on the end of the stem shaft to help with alignment.
34. Install four hex head bolts (Item 35) to complete installation of the motor cover and torque all six bolts to 28-35 ft/lbs. (Figure 9-38)



Figure 9-38 Complete Installation of Motor Cover

10 Troubleshooting

Periodic examination of all seals and o-rings for nicks, cuts and wear is recommended, disassembly procedures are covered in Chapter 9, Maintenance. If the control valve is found to be in need of repair, it is important that that service be performed by trained and qualified service personnel and it is recommended the user contact the Brode Meter Co., LLC Repair Department.

A table has been provided to aid in basic troubleshooting. The most frequent problem encountered with any control valve is the accumulation of

sediment, rouge, scale and other foreign material in the pilot or its supply system. It is therefore good practice to periodically remove the pilot from the valve and inspect it for accumulation of these materials.

The strainer and needle valve in the pilot supply line should also be flushed periodically to avoid erratic control and slow response typical to obstructed flow. If substandard conditions persist after thoroughly cleaning the system, examine the pilot for swollen O-rings.

Symptom	Possible Cause(s)	Test/Check	Corrective Action
Does not control.	Main valve piston.	Swollen O-rings due to fluid incompatibility?	Inspect O-rings, confirm correct elastomer compound, replace as necessary.
	Needle valve adjustment.	Are Needle valve(s) adjusted correctly?	Open needle valve(s), flush and reset.
	Pilot malfunction (electrical).	Signal logic from control device incorrectly programmed?	Correct programming logic at control device including set points, control tolerance, and timing delay as required.
		Valve stem mounted micro switches (cam settings) incorrectly adjusted?	Adjust cam settings to achieve correct control function.
		Valve stem mounted micro switches incorrectly wired?	Check wiring schematic and correct as necessary.
		Defective or worn O-rings or seals.	Inspect and replace O-rings and seals, as necessary.
	Pilot malfunction (hydraulic).	Pilot adjustment spring incorrectly set?	Adjust spring setting.
		Defective or worn O-rings or seals.	Inspect and replace O-rings and seals, as necessary.
		Incorrect spring range installed?	Inspect spring for proper control range.
Leaks.	O-rings or seals.	Damaged or worn O-rings or seals?	Replace as required.
	Indicator stem.	Bent indicator stem?	Replace indicator stem.

Table continued on next page.

Symptom	Possible Cause(s)	Test/Check	Corrective Action
Does not open or opens too slow.	No inlet pressure.	Is pump running?	Turn pump on.
	Isolation valves closed.	Upstream block valve closed?	Open valve.
		Downstream block valve closed?	Open valve.
	Insufficient inlet pressure.	Clogged strainer?	Clean strainer.
	Bypass valve.	Are bypass valve(s) closed?	Close bypass valve.
	Needle valve(s) closed or incorrectly set.	Needle valve(s) open?	Open needle valve(s), flush and reset.
	Internal valve strainer or sense lines.	Strainer or sense lines clogged?	Clean strainer/sense lines as necessary.
	Pilot malfunction (electrical).	Correct voltage at solenoid?	Correct voltage supply source and wiring.
		Signal logic from control device incorrectly programmed.	Correct programming logic at control device to include pump delay timer and low flow start settings.
		Defective solenoid?	Replace solenoid.
		Defective or worn O-rings or seals.	Inspect and replace O-rings and seals, as necessary.
Pilot malfunction (hydraulic).	Pilot adjustment spring incorrectly set?	Adjust spring setting.	
	Defective or worn O-rings or seals.	Inspect and replace O-rings and seals, as necessary.	
Does not close or closes too slow	Main valve piston.	Swollen O-rings due to fluid incompatibility?	Inspect O-rings, confirm correct elastomer compound, replace as necessary.
	Valve seat O-ring.	Seat O-ring cut or damaged?	Inspect and replace as necessary.
	Needle valve(s) closed or incorrectly set.	Needle valve(s) open?	Open needle valve(s), flush and reset
	Internal valve strainer or sense lines.	Strainer or sense lines clogged?	Clean strainer/sense lines as necessary.
	Indicator stem.	Bent indicator stem?	Replace indicator stem
	Pilot malfunction (electrical).	Incorrect wiring?	Check wiring with schematic and correct as necessary.
		Signal logic from control device incorrectly programmed?	Correct programming logic at control device to include zero shut-off control.
		Defective or worn O-rings or seals.	Inspect and replace O-rings and seals, as necessary.
	Pilot malfunction (hydraulic).	Defective or worn O-rings or seals.	Inspect and replace O-rings and seals, as necessary.

11 Parts Lists

General

This chapter contains the necessary parts required for routine maintenance and service of the Brodie Valve. Each parts list contains the recommended spare and replacement parts denoted by an asterisk. For items not listed, or additional information, consult the factory. When ordering, the following information must be furnished:

- Model Number
 - Serial Number
 - Part Number
 - Quantity
-

11.1.1 BV Series Valve Illustrated Parts List

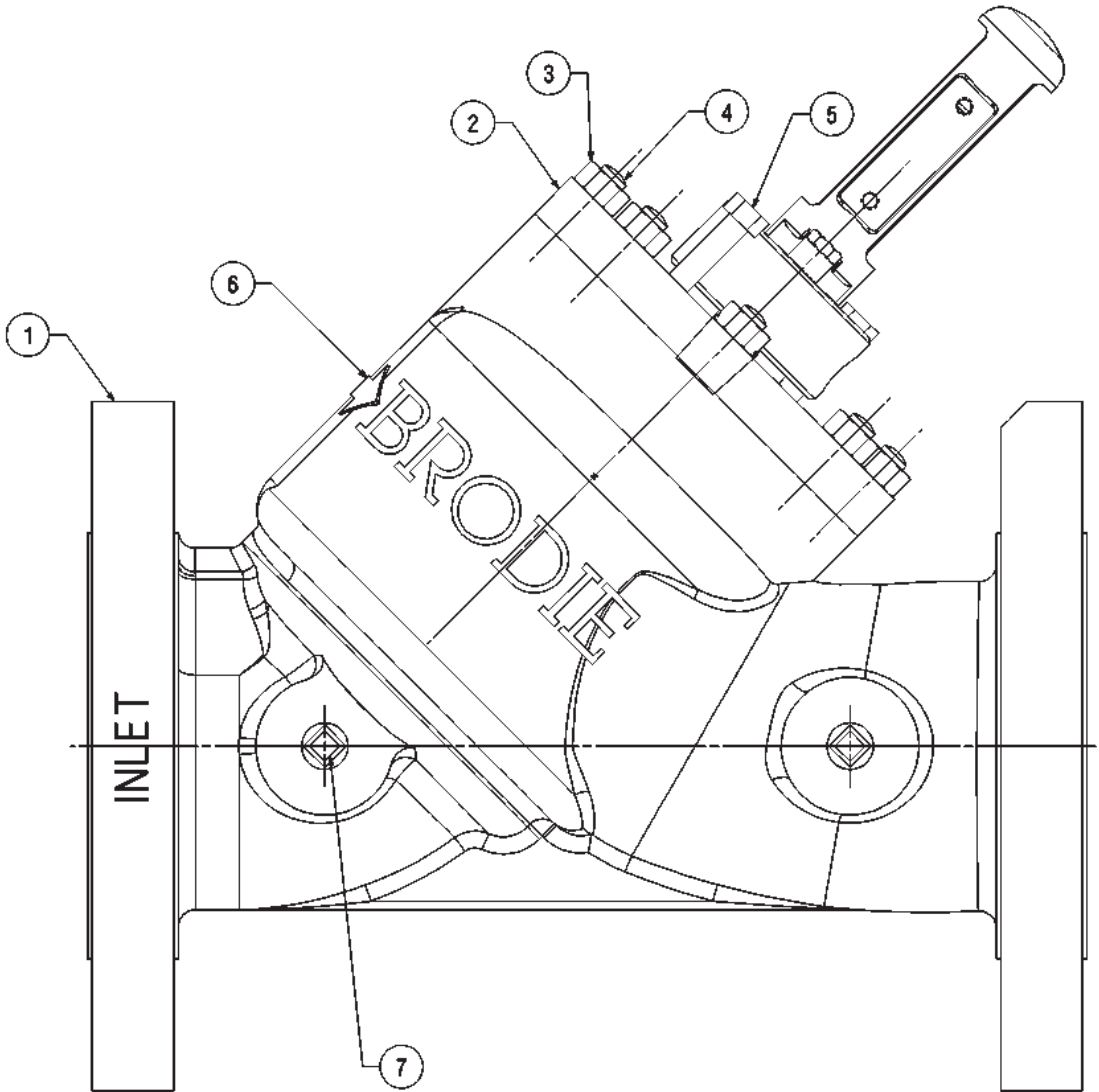

11.1.2 BV Series Valve Part Numbers

Item #	Description	Size				Qty.
		2"	2" AP	3"	3" AP	
1	Valve Body, 150#	VS21001M		VS31001M		1
	Valve Body, 300#	VS23001M		VS33001M		1
2	Cylinder Assembly	VS20075-421M	VS20075-426M	VS30075-421M	VS30075-426M	1
	Cylinder Assembly with Indicator	VS20175-421M	VS20175-426M	VS30175-421M	VS30175-426M	1
3	Nut	151546M Qty: 4		151547M Qty: 6		
4	Stud	151309M Qty: 4		151305M Qty: 6		
5	Set Screw	150691		150695		2
6	Nameplate	VS20019				1
7	Pipe Plug	154721M				2

Item #	Description	Size				Qty.
		4"	4" AP	6"	6" AP	
1	Valve Body, 150#	VS41001M		VS61001M		1
	Valve Body, 300#	VS43001M		VS63001M		1
2	Cylinder Assembly	VS40075-421M	VS40075-426M	VS60075-421M	VS60075-426M	1
	Cylinder Assembly with Indicator	VS40175-421M	VS40175-426M	VS60175-421M	VS60175-426M	1
3	Nut	151547M Qty: 8		151553M Qty: 10		
4	Stud	151305M Qty: 8		151347M Qty: 10		
5	Set Screw	150695				2
6	Nameplate	VS20019				1
7	Pipe Plug	154721M				2

Item #	Description	Size				Qty.
		8"	8" AP	12"	12" AP	
1	Valve Body, 150#	VS81001M	NA	VS121001M	NA	1
	Valve Body, 300#					1
2	Cylinder Assembly	VS80075-4XX		VS120075-4XX		1
	Cylinder Assembly with Indicator	VS80175-4XX				1
3	Nut	151558M (Qty 10)		151560M (Qty 12)		
4	Stud	151335M (Qty 10)		151395M (Qty 12)		
5	Set Screw	150696				2
6	Pipe Plug	154721M		154704M		2

11.2.2 2" Valve Cylinder Part Numbers

Item #	Description	2"	2" AP	Qty.
1	Cylinder Head	VS20056-500M		1
2	Cylinder	VS20471-600		1
3	Valve Spring	VS20059		1
4	Piston	VS20024-690	VS20024-693	1
4	Piston with Indicator	VS20124-690	VS20124-693	1
5	Seal Ring	VS20026-600		1
6	Retaining Ring	156460		1
7	Screw	151012M		4
8	O-ring/Teflon Seal	152073-XXX	159775	1 2
9	O-ring	152085-XXX	152085-XXX	1
10	O-ring	159029-XXX	159029-XXX	1
11	O-ring	157000-XXX	15700-XXX	2
12*	O-ring	152070-XXX	152070-XXX	1
13*	Piston Plug	VS40086		1
14*	Screw	151857		1
15*	Roll Pin	152119		2
16*	Indicator Guard Adaptor	VS40081M		1
17*	Screw	150727		2
18*	Washer	152119		2
19*	Bearing	VS40189-500		1
20*	Indicator Guard	VS40082		1
21*	Indicator Stem	VS20183		1
22*	Back-Up Ring	157172		2
23*	O-ring	152096-XXX	152096-XXX	1
24*	Seal Retainer	VS40188-500		1
25*	O-ring	157012-XXX	157012-XXX	1
26*	Screw	151010-019		1
27*	Piston Connector	VS40087		1
28*	Roll Pin	153540		1
29*	Screw	151544-019		1
30*	Seal Retainer			2
31*	Retaining Ring			2

O-Ring Code	
Viton-F	-026
Fluorosilicon	-016
EPR	-005
Neoprene	-116
Nitrile	-120
Kalrez	-075

*XXX: refer to O-Ring Code

Seal Kits	
Size	Model Code
2"	WVS21050-XXX
3"	WVS31050-XXX
4"	WVS41050-XXX
5"	WVS61050-XXX
6"	WVS81150-XXX

11.2.3 Valve Seal Kits

Description	2"	3"	4"	6"	8"
All O-Ring Cylinder					
Viton-F	WVS21050-402F	WVS31150-402F	WVS41050-402FM	WVS61050-402FM	
Viton-F w/Indicator	WVS21150-400F	WVS31150-402F	WVS41150-402F		
Low Swell Nitrile	WVS21050-410	WVS31150-400	WVS41050-420LS		
Neoprene	WVS21050-403	WVS31050-403	WVS41050-403	WVS61050-403	
Low Swell Viton (1289)	WVS21050-023	WVS31050-023	WVS41050-023	WVS61050-023	
AP Option Cylinder					
AP w/ Viton-F	WVS21050-426	WVS31050-426	WVS41050-426	WVS61050-426	WVS81050-426
AP w/ Viton-F w/ Indicator	WVS21150-402FM	WVS31150-406-2F	WVS41150-426	WVS61150-426	
AP w/Viton-A w/Indicator					WVS81150-402
AP w/Fluorosilicon	WVS21050-416	WVS31050-416	WVS41050-416	WVS61050-416	
AP w/Fluorosilicon w/Indicator	WVS21150-426	WVS31150-416	WVS41150-416	WVS61150-416	
AP w/Low Swell Nitrile	WVS21050-420	WVS31050-406	WVS41050-406M	WVS61050-406LS	WVS81050-420
Ap w/Low Swell Nitrile w/Indicator	WVS21150-406	WVS31150-406	WVS41150-406	WVS61050-406	
Neoprene	WVS21050-413	WVS31050-413	WVS41050-413		
Low Temp Viton (1289)	WVS21050-423	WVS31050-423	WVS41050-423	WVS61050-423	

11.3.1 3", 4", and 6" Valve Cylinder Illustrated Parts List

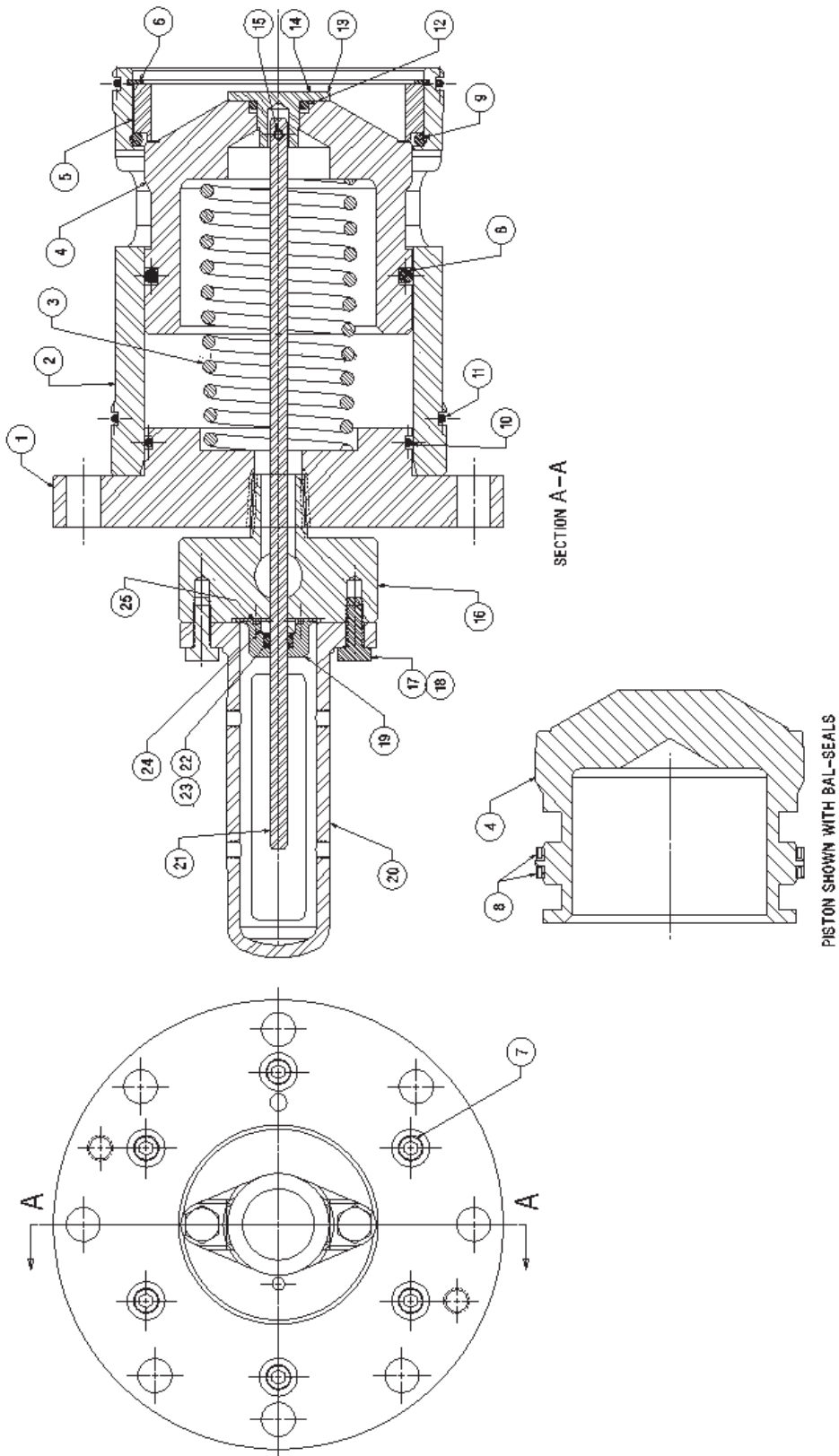

11.3.2 3" Valve Cylinder Part Numbers

Item #	Description	3"	3" AP	Qty.
1	Cylinder Head	VS30056-500M		1
2	Cylinder	VS30471-600		1
3	Valve Spring	VS30029		1
4	Piston	VS30024-690	VS30024-693	1
4	Piston with Indicator	VS30124-690	VS30124-693	1
5	Seal Ring	VS30026-600		1
6	Retaining Ring	156458		1
7	Screw	151012M		6
8	O-ring/Teflon Seal	152075-022	159714	1 2
9	O-ring	152100-022	152100-120	1
10	O-ring	159575-022	159575-120	1
11	O-ring	152095-022	152095-120	2
12*	O-ring	152048-022	152048-120	1
13*	Piston Plug	VS40053		1
14*	Screw	150333		3
15*	Roll Pin	153622		1
16*	Indicator Guard Adaptor	VS40081M		1
17*	Screw	150727		2
18*	Washer	152119		2
19*	Bearing	VS40189-500		1
20*	Indicator Guard	VS40082		1
21*	Indicator Stem	VS30183		1
22*	Back-Up Ring	157172		2
23*	O-ring	152096-022	152096-120	1
24*	Seal Retainer	VS40188-500		1
25*	O-ring	157012-022	157012-120	1

11.3.3 4" Valve Cylinder Part Numbers

Item #	Description	4"	4" AP	Qty.
1	Cylinder Head	VS40056-500M		1
2	Cylinder	VS40471-600		1
3	Valve Spring	VS40029		1
4	Piston	VS40024-690	VS40024-693	1
4	Piston with Indicator	VS40124-690	VS40124-693	1
5	Seal Ring	VS40026-600		1
6	Retaining Ring	156459		1
7	Screw	151012M		6
8	O-ring/Teflon Seal	152078-022	159715	1 2
9	O-ring	152080-022	152080-120	1
10	O-ring	157032-022	157032-120	1
11	O-ring	152094-022	152094-120	2
12*	O-ring	152048-022	152048-120	1
13*	Piston Plug	VS40053		1
14*	Screw	150333		3
15*	Roll Pin	153622		1
16*	Indicator Guard Adaptor	VS40081M		1
17*	Screw	150727		2
18*	Washer	152119		2
19*	Bearing	VS40189-500		1
20*	Indicator Guard	VS40082		1
21*	Indicator Stem	VS40183		1
22*	Back-Up Ring	157172		2
23*	O-ring	152096-022	152096-120	1
24*	Seal Retainer	VS40188-500		1
25*	O-ring	157012-022	157012-120	1

11.3.4 6" Valve Cylinder Part Numbers

Item #	Description	6"	6" AP	Qty.
1	Cylinder Head	VS60056-500M		1
2	Cylinder	VS60471-600		1
3	Valve Spring	VS60029		1
4	Piston	VS60024-690	VS60024-693	1
4	Piston with Indicator	VS60124-690	VS60124-693	1
5	Seal Ring	VS60026-600		1
6	Retaining Ring	156461		1
7	Screw	151012M		8
8	O-ring/Teflon Seal	157022-022	159716	1 2
9	O-ring	157003-022	157003-120	1
10	O-ring	159576-022	159576-120	1
11	O-ring	152079-022	152079-120	2
12*	O-ring	152048-022	152048-120	1
13*	Piston Plug	VS40053		1
14*	Screw	150333		3
15*	Roll Pin	153622		1
16*	Indicator Guard Adaptor	VS40081M		1
17*	Screw	150727		2
18*	Washer	152119		2
19*	Bearing	VS40189-500		1
20*	Indicator Guard	VS40082		1
21*	Indicator Stem	VS60183		1
22*	Back-Up Ring	157172		2
23*	O-ring	152096-022	152096-120	1
24*	Seal Retainer	VS40188-500		1
25*	O-ring	157012-022	157012-120	1

11.3.4 8" & 12" Valve Cylinder Illustrated Parts

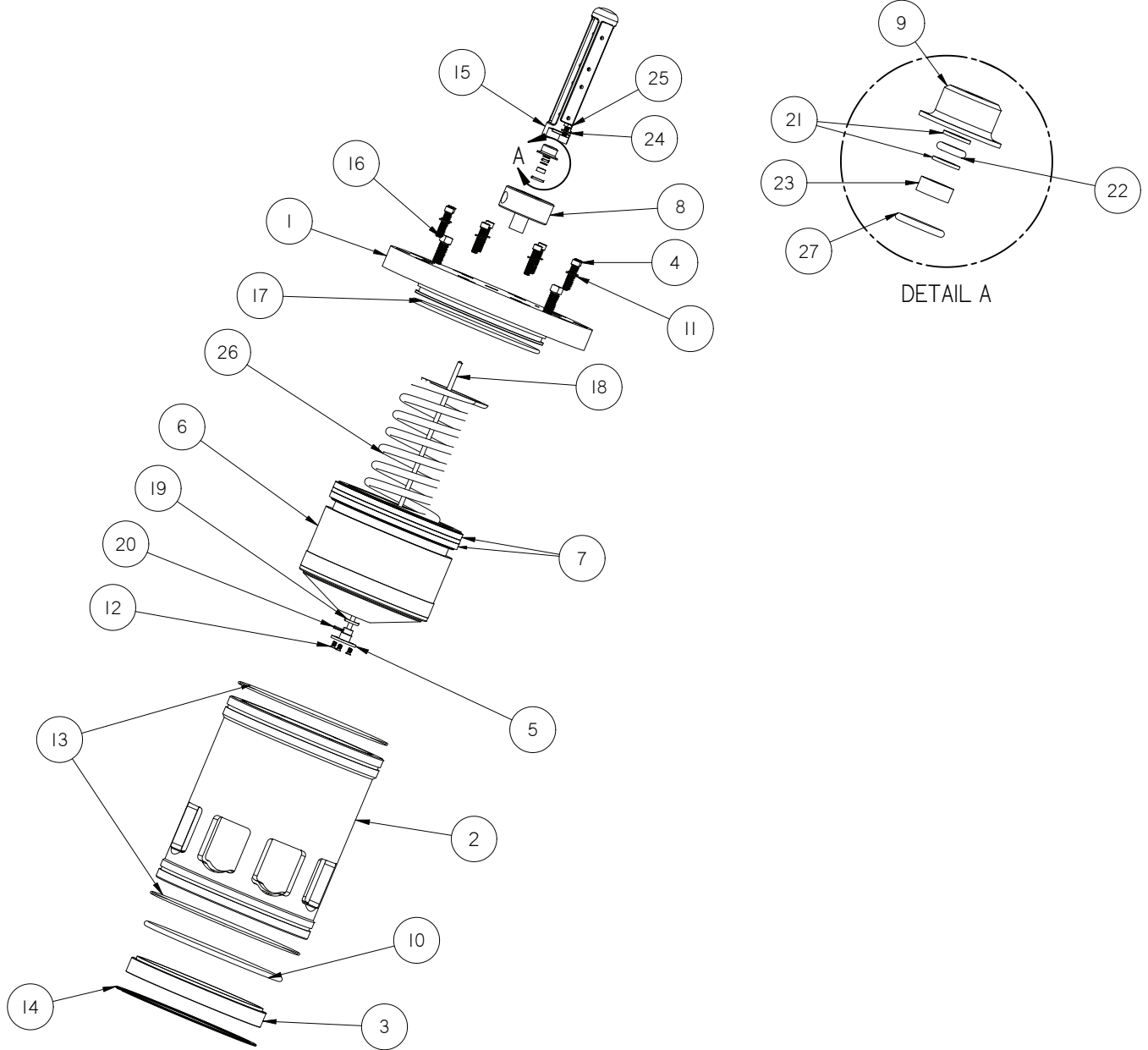

11.3.5 8" Valve Cylinder Part Numbers

Item #	Description	8"	8" AP	Qty.
1	Cylinder Head	VS80056-500M		1
2	Cylinder	VS80471-600		1
3	Valve Spring	VS80029 (5/10 psi)		1
4	Piston		VS80024-693	1
4	Piston with Indicator		VS80124-693	1
5	Seal Ring	VS80026-600		1
6	Retaining Ring	156464		1
7	Screw	151460M		8
	Washer	151859		8
8	O-ring/Teflon Seal		159777	2
9	O-ring	157006-XXX		1
10	O-ring	157004-XXX		1
11	O-ring	152074-XXX		2
12*	O-ring	152048-XXX		1
13*	Piston Plug	VS40053		1
14*	Screw	150333		3
15*	Roll Pin	153622		1
16*	Indicator Guard Adaptor	VS40081M		1
17*	Screw	150727		2
18*	Washer	152119		2
19*	Bearing	VS40189-500		1
20*	Indicator Guard	VS80082		1
21*	Indicator Stem	VS80183		1
22*	Back-Up Ring	157172		2
23*	O-ring	152096-XXX		2
24*	Seal Retainer	VS40188-500		1
25*	O-ring	157012-XXX		

11.3.6 12" Valve Cylinder Part Numbers

Item #	Description	12"	12" AP	Qty.
1	Cylinder Head	VS120056-500M		1
2	Cylinder	VS12471-600		1
3	Valve Spring	VS120029 (5/10 psi)		1
4	Piston	VS120024-690		1
4	Piston with Indicator			1
5	Seal Ring	VS120026-600		1
6	Retaining Ring	156470		1
7	Screw Washer	1500994M 1501086		6 6
8	O-ring/Teflon Seal			
9	O-ring	157018-XXX		
10	O-ring	157017-XXX		
11	O-ring	157030-XXX		
12*	O-ring	157019-XXX		
13*	Piston Plug			
14*	Screw			
15*	Roll Pin			
16*	Indicator Guard Adaptor			
17*	Screw	150727		2
18*	Washer	152199		2
19*	Bearing			
20*	Indicator Guard			
21*	Indicator Stem			
22*	Back-Up Ring	157172		2
23*	O-ring	152096-XXX		1
24*	Seal Retainer			
25*	O-ring	157012-XXX		1

11.4.1 Model BV28 Illustrated Parts List

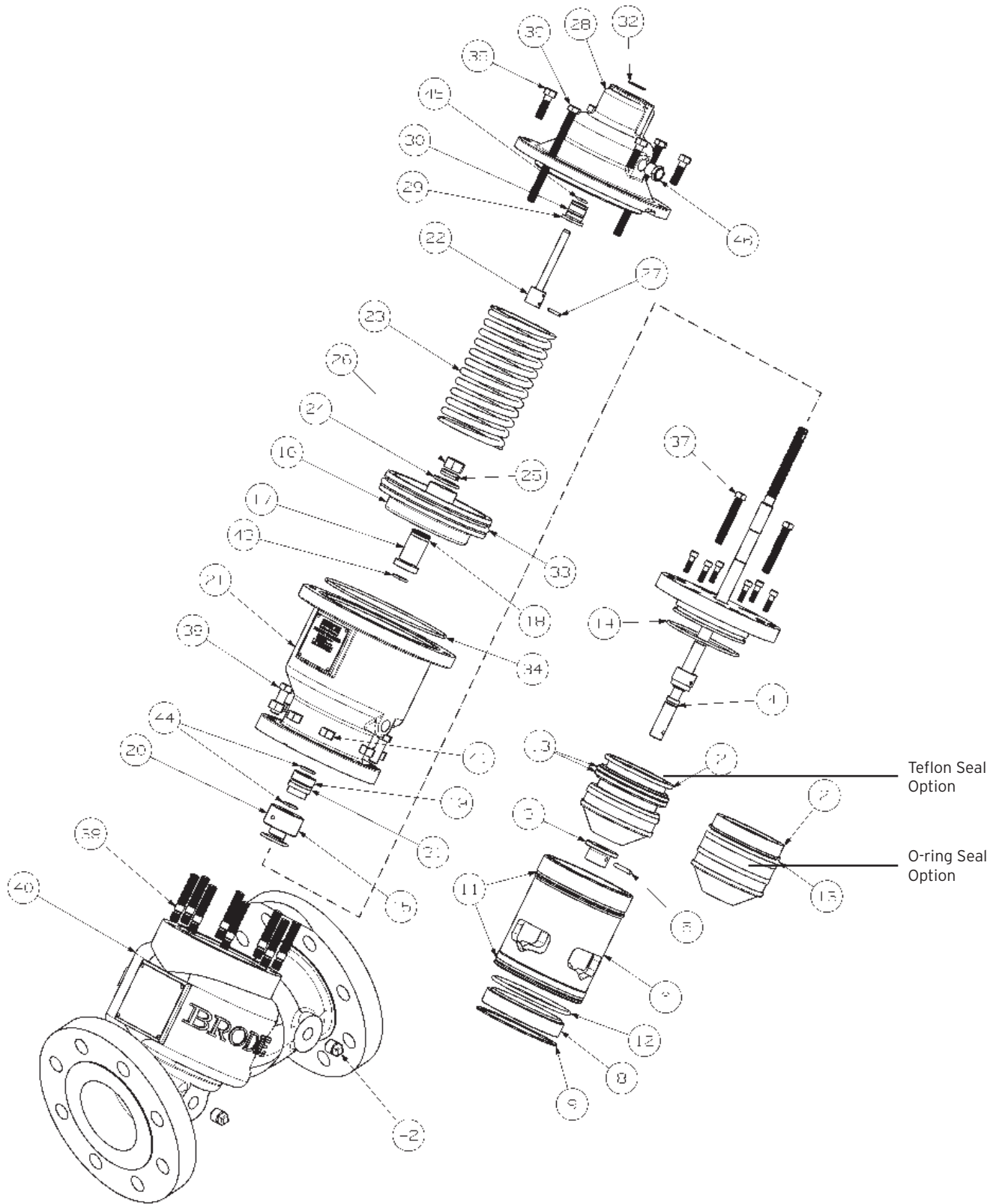

11.4.2 Model BV28 Part Numbers

Item #	Description	3"	4"	6"	Qty.
1	Shaft Assembly	VS30235-026	VS60235-001	VS66235-100	1
2	Valve Piston	VS30224-690	VS40224-690	VS60224-690	1
3	Lifting Collar	VS30238	VS60238		1
4	O-ring	152070-026			1
5	Pin	153560			1
6	Valve Cylinder	VS30471-600	VS40471-600	VS60471-600	1
7	Cylinder Head	VS30056-503	VS40056-503	VS60056-503M	1
8	Seal Ring	VS30026-600	VS40026-600	VS60026-600	1
9	Retaining Ring	156458	156459	156461	1
10	SHCS	151012M Qty: 6		151012M Qty: 8	
11	O-ring	152095-026	152094-026	152079-026	2
12	O-ring	152100-026	152080-026	157003-026	1
13	O-ring	152075-026	152078-026	157002-026	1
13	Teflon Seal	159714	159715	159716	1
14	O-ring	159575-026	157032-026	159576-026	1
15	O-ring	152097-026			1
16	Motor Piston	VS30611-110	VS00611-110		1
17	Piston Bushing	VS00612			1
18	O-ring	152068			1
19	Upper Gland	VS00621-600			1
20	Lower Gland	VS00622-600			1
21	Motor Housing	VS30601-600M	VS40601-600M	VS60601-600M	1
22	Valve Indicator	VS00630		VS60630	1
23	Spring	VS30632-112	VS33160-112	VS00632	1
24	Flat Washer	1501010			1
25	Lockwasher	152111			1
26	Hex Nut 1/2-13	151555M			1
27	Pin	153554			1
28	Motor Cover	VS30606-600M	VS40606-600M		1
29	Indicator Gland	VS00607			1
30	O-ring	157024			1
31	O-ring	157010-026			1
32	Retaining Ring	156472			1
33	O-ring	157027	157002		1
34	O-ring	157026	157025		1
35	Hex Bolt	150767M			4
36	Hex Bolt	1501014			2
37	Lifting Lug	1501013		150695	2

Table continued on next page.

11.4.2 Model BV28 Part Numbers List cont.

Item #	Description	3"	4"	6"	Qty.
38	Hex Bolt	150786M Qty: 2		150767M Qty: 8	
39	Stud	1501011M Qty: 6	1501011M Qty: 8	151451M Qty: 10	
40	Valve Body	VS31001M	VS41001M	VS61001M	1
41	Hex Nut	151547M	151547M Qty: 8	151553M Qty: 10	
42	Pipe Plug	154721M			2
43	O-ring	152090			1
44	O-ring	152090-026			2
45	O-ring	152076			1
46	Vent	159799			1
**	Seal Kit	WVS31225	WVS41225	WVS61225	1

11.5.1 Model BV28 Shaft Assembly Illustrated Parts List

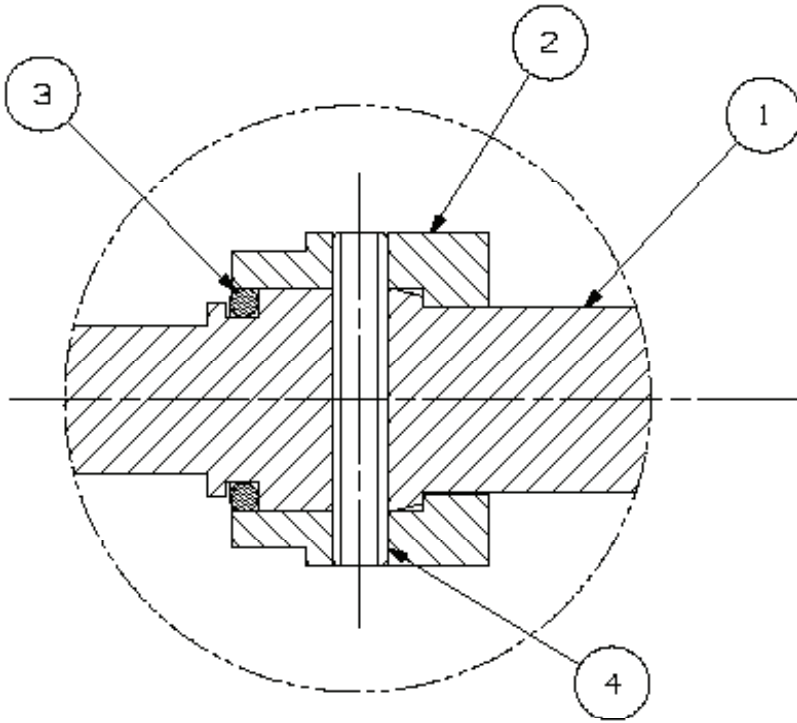

11.5.2 Model BV28 Shaft Assembly Part Numbers

Item #	Description	3"	4"	6"	Qty.
1	Shaft	VS30236	VS60236	VS66237	1
2	Coupling Seal	VS60237			1
3	O-ring	157012-026			1
4	Spirol Pin	153560			1

11.6.1 Model BV28 Single Microswitch Assembly Illustrated Parts List

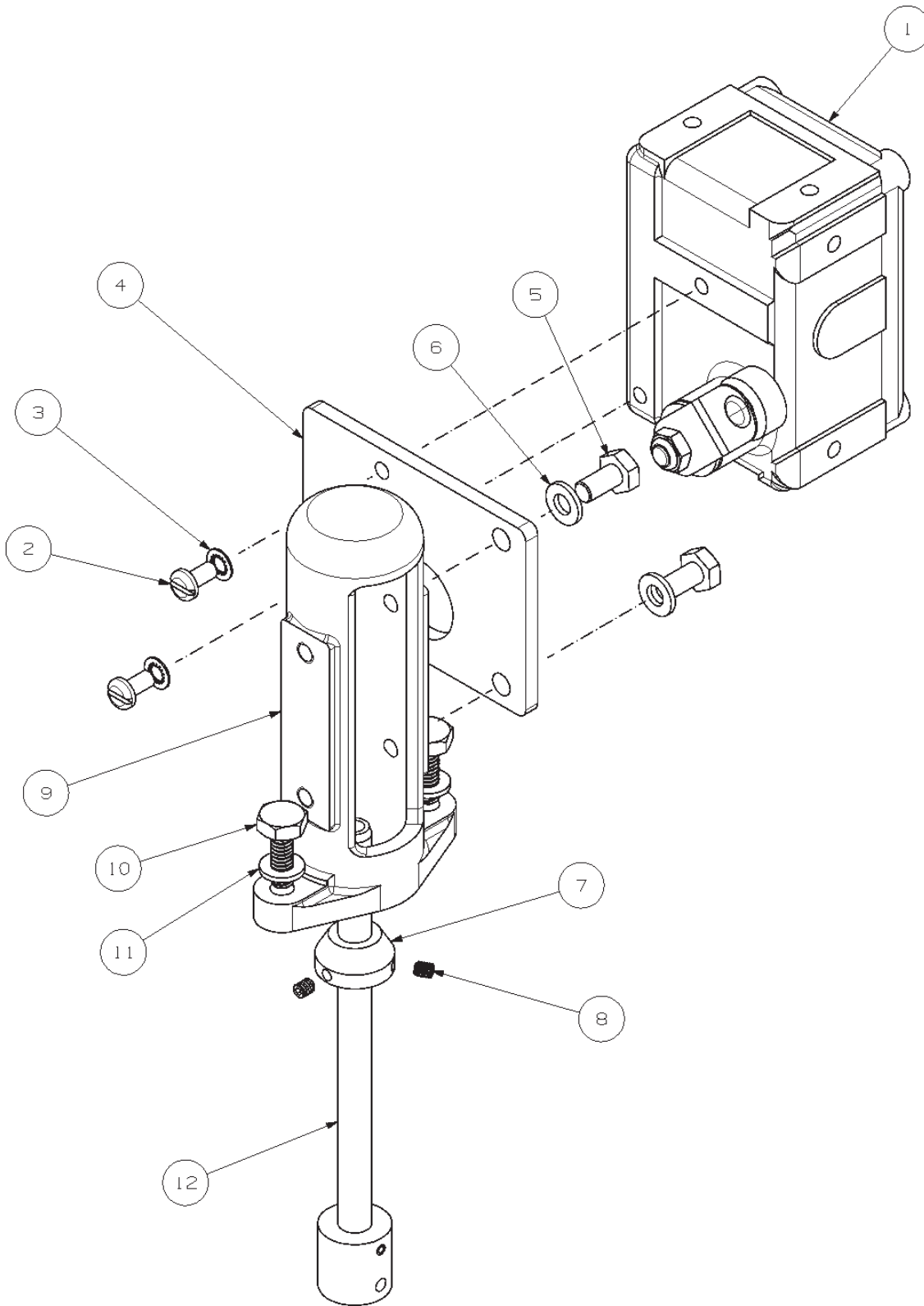

11.6.2 Model BV28 Single Microswitch Assembly Part Numbers

Item #14	Description	Part Number	Qty.
1	Electric Control Switch	VP6090	1
2	Screw	150134	2
3	Lockwasher	152259	2
4	Mounting Plate	VP60902-001	1
5	Hex Head Screw	150725	2
6	Lockwasher	152119	2
7	Trip Dog	VS460907	1
8	Set Screw	150975-419	2
9	Indicator Guard	VS40082	1
10	Hex Head Screw	150727	2
11	Lockwasher	152119	2
12	Indicator Shaft Assembly	VS60633	1

11.7.1 Model BV28 Double Microswitch Assembly Illustrated Parts List

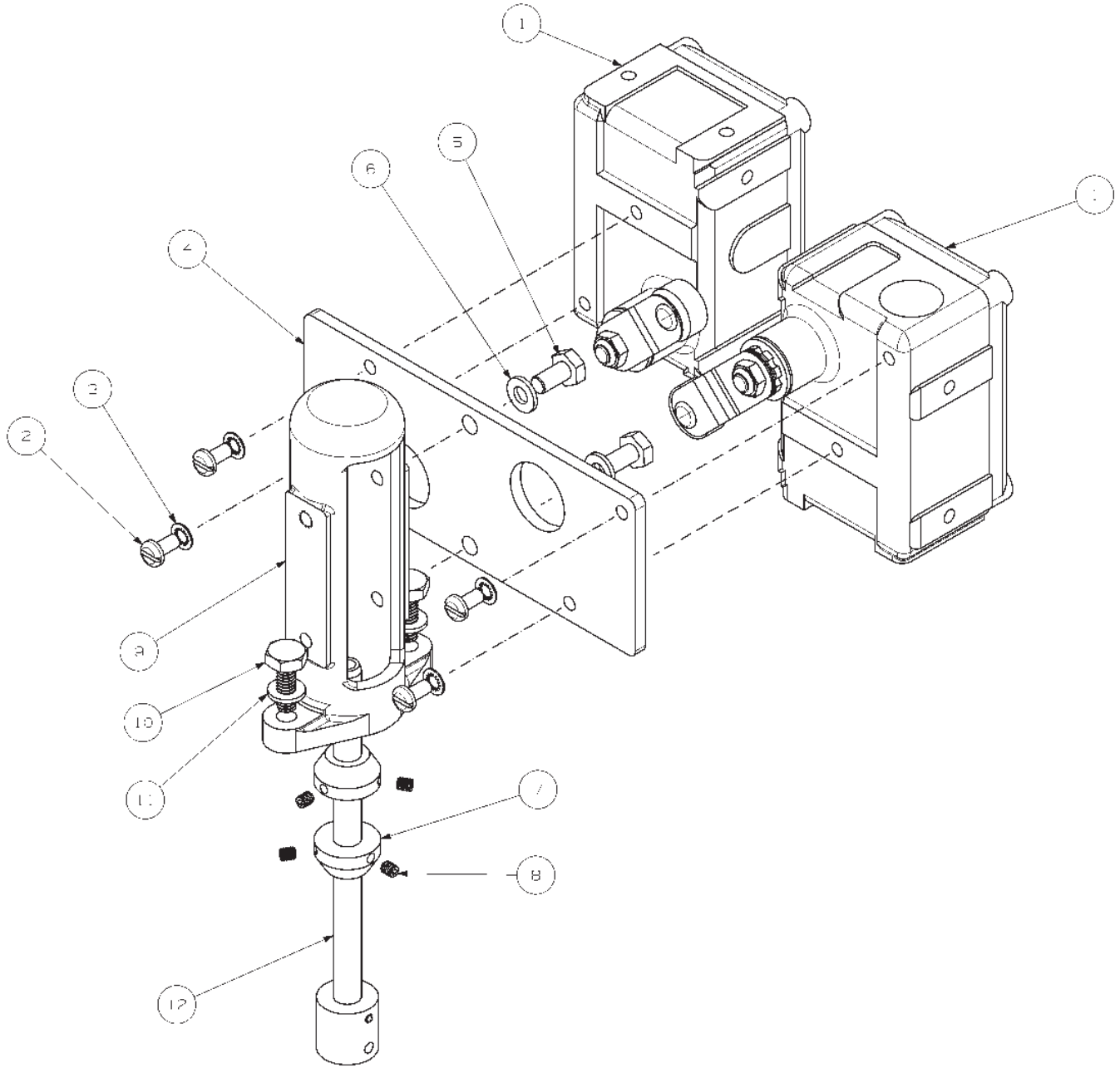

11.7.2 Model BV28 Double Microswitch Assembly Part Numbers

Item #14	Description	Part Number	Qty.
1	Electric Control Switch	VP6090	2
2	Screw	150134	4
3	Lockwasher	152259	4
4	Mounting Plate	VP60903-001	1
5	Hex Head Screw	150725	2
6	Lockwasher	152119	2
7	Trip Dog	VS460907	2
8	Set Screw	150975-419	4
9	Indicator Guard	VS40082	1
10	Hex Head Screw	150727	2
11	Lockwasher	152119	2
12	Indicator Shaft Assembly	VS60633	1

Appendix A

Decontamination Statement

RMA Number: _____

Item Being Returned: _____

List all chemicals, process fluids and gases that have come in contact with the equipment, including cleaning agents. Attach additional pages of information if necessary. A Material Safety Data Sheet (MSDS) is required if non-food grade products have been used with the item being returned.

Information Required	Product 1	Product 2
Chemical Name		
Health and Safety Hazards		
Precautions, First Aid		

I hereby certify the equipment being returned has been cleaned and decontaminated in accordance with good industrial practices and in compliance with OSHA and DOT regulations. This equipment poses no health or safety risks due to contamination.

Signature: _____

Name (Please Print): _____

Title: _____

Company Name: _____

Phone Number: _____

Fax: _____

E-mail: _____

Reason for Return: _____

REMINDER

All items being returned must be packaged separately. This decontamination statement and the MSDS sheet(s) must be placed on the outside of the shipping container.

Appendix B

Customer Problem Report

For faster service, complete this form and return it along with the affected equipment to customer service at the address indicated below. If you require technical assistance, please contact the Product Service Department at the phone number listed below.

Company Name: _____ Phone: _____

Technical Contact: _____

Repair PO#: _____

Invoice Address: _____

Shipping Address: _____

Return Shipping Method: _____ S/N: _____

Equipment Model #: _____ Failure Date: _____

Description of Problem: _____

What was happening at time of failure: _____

Additional Comments: _____

Report Prepared by: _____ Title: _____

Brodie International

P.O. Box 450 (30459-0450)
19267 Highway 301 North
Statesboro, GA, 30461
USA

Email: sales@brodieintl.com
Phone: +1 (912) 489-0200
Fax: +1 (912) 489-0294