

Parts List

BCBS Strainer and Combination Air Eliminators-Strainer



Flow meters will measure, not only liquid, but entrained air and vapor in the liquid. To insure correct measurement, air and vapor must be removed before the liquid enters the meter. Brodie Air Eliminators are designed to provide separation, elimination and prevention of air in piping systems for a variety of installations and conditions.

This parts list contains the necessary parts required to make up any standard unit covered within this bulletin. For items that are not listed or for additional information, consult factory.

Table of Contents

1 Read Me First	3
2 Essential Instructions	4
3 Warranty Claim Procedures	8
4 Receipt of Shipment	12
5 Return of Equipment	12
6 Storage	13
7 Description	14
8 Maintenance	15
9 Strainer Bill of Material	16
10 Troubleshooting	19
11 Air Eliminator Bill of Material	20

1 Read Me First

Notice

Brodie International, a Brodie Meter Co., LLC Company (“Brodie”) shall not be liable for technical or editorial errors in this manual or omissions from this manual.

Brodie makes no warranties, expressed or implied, including the implied warranties of merchantability and fitness for a particular purpose with respect to this manual and, in no event, shall Brodie be liable for any special or consequential damages including, but not limited to, loss of production, loss of profits, etc.

Product names used herein are for manufacturer or supplier identification only and may be trademarks/registered trademarks of these companies. The contents of this publication are presented for informational purposes only, and

while every effort has been made to ensure their accuracy, they are not to be construed as warranties or guarantees, expressed or implied, regarding the products or services described herein or their use or applicability. We reserve the right to modify or improve the designs or specifications of such products at any time.

Brodie does not assume responsibility for the selection, use or maintenance of any product. Responsibility for proper selection, use and maintenance of any Brodie product remains solely with the purchaser and end-user.

No part of this work may be reproduced or copied in any form or by any means - graphic, electronic or mechanical - without first receiving the written permission of Brodie International.

2 Essential Instructions

General

Brodie International designs, manufactures and tests its products to meet many international standards. As the instruments are sophisticated technical products they must be installed, used and maintained properly to ensure they continue to operate within their normal specifications. The following instructions must be adhered to and incorporated into onsite safety programs where possible.

Read all instructions prior to installing, operating, and servicing the product. If this instruction manual is not the correct manual, telephone +1 912 489 0200 and the requested manual will be provided.

Save this instruction manual for future reference. If you do not understand any of the instructions, contact your Brodie representative for clarification.

Follow all warnings, cautions, and instructions marked on and supplied with the product. Inform and educate your personnel in the proper installation, operation, and maintenance of the product. Install your equipment as specified in the installation instructions of the appropriate instruction manual and per applicable local and national codes. Connect all products to the proper electrical and pressure sources.

To ensure proper performance, use qualified personnel to install, operate, update, program, and maintain the product. When replacement parts are required, ensure that qualified personnel use replacement parts specified by the manufacturer.

Unauthorized parts and procedures can affect the product's performance and place the safe operation of your process at risk. Look-alike substitutions may result in fire, electrical hazards, or improper operation.

Ensure that all equipment doors are closed and protective covers are in place, except when maintenance is being performed by qualified personnel, to prevent electrical shock and personal injury.

It is the customer's responsibility to provide fire prevention measures and equipment per local regulations.

Use of this equipment for any purpose other than its intended purpose may result in property damage and/or serious personal injury or death.

Essential Instructions for Pressure Containing Equipment, Including the European Union (Directive 2014/68/EU)

When installing the equipment the bolting must conform to the requirements of ASME B16.5, paragraph 5.3, and to the material requirements of ASME B16.5, Table 1B. Gaskets must conform to the requirements of ASME B16.20.

Although it is not expected for the device to be used in a service where it would come in to contact with unstable fluids, it is the end user's responsibility to assess any risks and take any precautions necessary.

It is the end user's responsibility to ensure that piping and other attachments connected to the Brodie instrument do not place adverse stresses upon it, the design of the instrument has not been assessed for the effects of traffic, wind or earthquake loadings.

It is the end user's responsibility to ensure that the instrument is mounted when required on suitable supporting foundations.

It is the end user's responsibility to install the device in a well-designed system to avoid potential hazards such as water hammer, vacuum collapse or uncontrolled chemical reactions.

It is the end user's responsibility to provide fire protection measures and equipment in accordance with the local regulations.

It is the end user's responsibility to install suitable straining and air/gas elimination systems.

The instrument has been designed without allowance for corrosion or other chemical attack. The end user should implement a periodic inspection and maintenance program to ensure that none of the instruments pressure containing components have been subject to any corrosion. It is possible to examine the instrument for evidence of corrosion through the inlet and the outlet.

When the ambient temperature is below the minimum operating temperature specified on the device it is the end user's responsibility to ensure that the device is warmed to an appropriated temperature before being pressurized.

Do not exceed the operating pressure and temperature limits of the instrument as stamped on the nameplates.

It is the customer's responsibility to install this equipment in a system that provides adequate over-pressure protection and that limit pressure surges to 10% of the maximum allowable working pressure of the instrument.

It is the end user's responsibility to provide fire protection measures and equipment in accordance with the local regulations.

3 Warranty Claim Procedures

These terms and conditions, the attendant quotation or the acknowledgement, and all documents incorporated by reference therein, binds Brodie Meter Co., LLC, who issues the quotation or acknowledgment for the provision of services and/or the sale of goods (except as provided in Section 11), to be provided hereunder by seller (Brodie Meter Co., LLC) hereinafter Seller, and the buyer, hereinafter Buyer, and constitute the entire agreement (Agreement) between Buyer and Seller regarding such sale and/or provision. To the extent not in conflict with the superseding terms of the Sales Order, these terms and conditions will be in force.

1. **PRICES:** Unless otherwise specified by Seller, Seller's price for the Goods and/or Services shall remain in effect for thirty (30) days after the date of Seller's quotation or acceptance of the order for the Goods/Services, whichever is delivered first, provided an unconditional, complete authorization for the immediate manufacture and shipment of the Goods and/or provision of Services pursuant to Seller's standard order processing procedures is received and accepted by Seller within such time period. If such authorization is not received by Seller within such thirty (30) day period, Seller shall exercise the right to change the price for the Goods/Services to Seller's price in effect for the Goods/Services at the time the order is released to final manufacture. Notwithstanding any of the foregoing to the contrary, the price for Goods/Services sold by Seller, but manufactured by others, shall be Seller's price in effect at the time of shipment to Buyer.

2. **DELIVERY, PASSING OF RISK, RETENTION OF TITLE, AND DOCUMENTATION:** All shipping dates are approximate and are based upon Seller's prompt receipt of all necessary information from Buyer to properly process the order. Any agreed

trade term shall be construed in accordance with the INCOTERMS® in force at the formulation of the contract. If no trade term has been specifically agreed, the delivery shall be F.O.B. Brodie Factory, FCA Brodie Factory, or EXWORKS Brodie Factory. Notwithstanding, any provisions to the contrary in this or other documents related to this transaction, the passing of risk of loss thereto shall transfer to Buyer upon delivery to the first freight carrier at the shipping point. The Goods shall remain the property of the Seller until paid for in full to the extent that such retention of title is valid under the relevant law. The retention of title shall not affect the passing of risk. The Seller shall provide Buyer with that data/documentation which is specifically identified in the contract. If additional copies of data / documentation or non-standard data/documentation are to be provided by Seller, they shall be provided to Buyer at Seller's price then in effect.

3. **EXCUSE OF PERFORMANCE:** Seller shall not be liable for delays in performance or for non-performance due to acts of God, war, riot, fire, labor trouble, unavailability of materials or components, explosion, accident, compliance with governmental requests, laws, regulations, orders or actions, or other unforeseen circumstances or causes beyond Seller's reasonable control.

4. **CHANGE, CANCELLATION AND RESTOCKING CHARGES:** Once an order has been acknowledged by the Seller, any changes requested by the Buyer must be communicated to the Seller. The Seller will notify the Buyer of any fees associated with the requested change. Buyer may terminate or suspend its non-shipped order for any or all of the Goods/Services covered by the Agreement, provided that Buyer gives Seller reasonable advance written notice of such termination or suspension and reimburses Seller accordingly:

25% of Net Order after Release to Engineering, 50% of Net Order after Release to Manufacturing, 75% of Net order after 50% Manufacture Complete and 100% of Net Order once Manufacturing is complete. Any request for return of product already shipped to Buyer will be at the discretion of Brodie. If so approved, a Return Authorization will be provided and a restocking fee assessed.

5. LIMITED WARRANTY: Subject to the limitations contained in Section 2 herein and except as otherwise expressly provided herein, Brodie Meter Co., LLC ("Brodie") warrants the Goods-manufactured by Brodie will be free from defects in materials or workmanship under normal use and care until the expiration of the applicable warranty period. Goods are warranted for twelve (12) months from the date of installation and 18 months from date of shipment, whichever occurs first. Consumables and Services are warranted for a period of 90 days from the date of shipment or completion of the Services. Products purchased by Brodie from a third party for resale to Buyer ("Resale Products") shall carry only the warranty extended by the original manufacturer. Buyer agrees that Brodie has no liability for Resale Products beyond making a reasonable commercial effort to arrange for procurement and shipping of the Resale Products. If Buyer discovers any warranty defects and notifies Brodie thereof in writing during the applicable warranty period, Brodie shall, at its option, repair or replace, that portion of the Goods found by Brodie to be defective or refund the purchase price of the defective portion of the Goods/Services. All replacements or repairs necessitated by inadequate maintenance, normal wear and usage, unsuitable power sources, unsuitable environmental conditions, accident, misuse, improper installation, modification, repair, storage or handling, or any other cause not the fault of Brodie, are not covered by this limited warranty, and shall be at Buyer's expense. Brodie shall not be obligated to pay any costs or charges incurred by Buyer or any other party except as may be agreed upon in writing in advance by an authorized Brodie representative. All costs of dismantling,

reinstallation and freight and the time and expenses of Brodie's personnel for site travel and diagnosis under this warranty clause shall be borne by Buyer unless accepted in writing by Brodie. Brodie is not responsible for damages that incur during shipment to Buyer for shipments that are F.O.B. Brodie Factory, FCA Brodie Factory, or EXWORKS Brodie Factory. Shipping charges for goods returned to Brodie under warranty will be at Buyer's expense. Products found not to be warranted can be repaired and returned at Buyer's expense and return charges born by Brodie will be added to the cost of repair or returned to Buyer "as received" at Buyer's expense. Insurance for returned products will be at Buyer's expense. For all returned products please package to prevent damage, or future damage during shipment. Make sure the products are cleaned, free from grease oil, chemicals and other materials that may hamper defect detection and impede repair. All returned items must be accompanied with a MSDS for the products that have been in contact with the equipment, including cleaning agents. A decontamination statement, RMA, and Customer Problem Report must also accompany equipment returned. Product received in an unsuitable condition will be returned at Buyer's expense without being examined. Goods repaired, and parts replaced during the warranty period shall be in warranty for the remainder of the original warranty period or ninety (90) days, whichever is longer. This limited warranty is the only warranty made by Brodie and can be amended only in a writing signed by an authorized representative of Brodie. Except as otherwise expressly provided in the Agreement, there are no representations or warranties of any kind, expressed or implied, as to merchantability, fitness for a particular purpose, or any other matter with respect to any of the goods or services. It is understood that corrosion or erosion of materials is not covered by our guarantee unless the Buyer has notified the Seller the product will be used in an environment conducive to corrosion and/or erosion and the product has been coated with Brodie's recommended method of protection against corrosion / erosion.

6. **LIMITATION OF REMEDY AND LIABILITY:** Brodie shall not be liable for damages caused in delay in performance. The sole and exclusive remedy for breach of warranty hereunder shall be limited to repair, correction, replacement or refund of purchase price under the limited warranty clause in section 5. In no event, regardless of the form of the claim or cause of action (whether based in contract, infringement, negligence, strict liability, other tort or otherwise), shall Brodie's liability to buyer and/or its customers exceed the price to buyer of the specific goods manufactured or services provided by Brodie giving rise to the claim or cause of action. Buyer agrees that in no event shall Brodie's liability to buyer and/or its customers extend to include incidental, consequential or punitive damages. The term "consequential damages" shall include, but not be limited to, loss of anticipated profits, loss of use, loss of revenue and cost of capital.

7. **PATENTS:** Subject to the limitations contained in Section 6, Seller shall defend any suits brought against Buyer based on a claim that use of the Goods manufactured by Seller constitutes an infringement of a valid patent of the United States, and shall pay any damages awarded therein against Buyer, provided that Buyer: promptly notifies Seller in writing of the filing of such suit or the threat thereof; permits Seller to control completely the defense or compromise of such claim of infringement; and provides all reasonable assistance and cooperation requested by Seller for the defense of such suit. In the event that only the Goods manufactured by Seller are held to be infringing in such suit and their use is enjoined, Seller shall, at its sole option and expense, provide a commercially reasonable alternative, including, but not limited to, procuring for Buyer the right to continue using the Goods, replacing them with a non-infringing product or modifying them so they become non-infringing. Buyer agrees that Seller shall not be liable for infringement, and that Buyer shall fully indemnify Seller therefore, if infringement is based upon the use of Goods in connection with Goods not manufactured by Seller or in a manner for which the Goods were not designed by the Seller or if the Goods were not designed by the

Seller or if the Goods were designed by the Buyer or were modified by or for the Buyer in a manner to cause them to become infringing.

8. **INSTALLATION:** Buyer shall be responsible for receiving, storing, installing, starting up and maintaining all Goods. Seller shall provide a quotation for services to assist Buyer in these functions if requested.

9. **TAXES:** Any tax or governmental charge payable by the Seller because of the manufacture, sale or delivery of the Goods, or provision of Services, may at Seller's option be added to the price herein specified. The foregoing shall not apply to taxes based upon Seller's net income.

10. **TERMS OF SHIPMENT AND PAYMENT:** Subject to the approval of Seller's Credit Department, shipping terms are F.O.B. Brodie Factory, FCA Brodie Factory, or EXWORKS Brodie Factory. Payment terms are subject to the approval of Seller's Credit Department and may vary based on Buyer's creditworthiness. Payment is expected, in U.S. currency, as per the prearranged agreement between the Buyer and Seller stated on the sales order. In the absence of such agreement, payment, in U.S. currency, is due Net30 days from the date of invoice. If any payment owed to Seller hereunder is not paid when due, it shall bear interest, at a rate to be determined by Seller which shall not exceed the maximum rate permitted by law, from the date on which it is due until it is received. Seller shall have the right, among other remedies, either to terminate the Agreement or to suspend further deliveries under this and/or other agreements with Buyer in the event Buyer fails to make any payment hereunder when due. Buyer shall be liable for all expenses incurred for collection of past due amounts, including attorneys' fees.

11. **STORAGE FEES**

1. Per diem charges are applicable when equipment is held beyond the acknowledged ready for shipment date.

Per diem storage charges will be assessed on each calendar day excluding the date of readiness.

The customer shall indemnify and hold Brodie In-

ternational harmless from any and all liability and expense for such damages that might result from extended storage beyond six months. Brodie may place the cargo in another warehouse facility with all charges associated with the transfer and storage to be paid by the customer.

12. **SOFTWARE AND FIRMWARE:** Notwithstanding any other provision herein to the contrary, Seller or applicable third-party owner shall retain all rights of ownership and title in its respective firmware and software, including all copyrights relating to such firmware and software and all copies of such firmware and software. Except as otherwise provided herein, Buyer is hereby granted a nonexclusive, royalty free license to use firmware and software, and copies of firmware and software, incorporated into the Goods only in conjunction with such Goods and only at the Buyer's plant site where the Goods are first used. Buyer may negotiate with Seller separate licenses to use such copies and firmware and software at other plant sites. Buyer's use of certain firmware (as specified by Seller) and all other software shall be governed exclusively by Seller's and/or third-party owner's applicable license terms.

13. **BUYER SUPPLIED DATA:** To the extent that Seller has relied upon any specifications, information, representation of operating conditions or other data or information supplied by Buyer to Seller in the selection or design of the Goods and/or provision of the Services and the preparation of Seller's quotation, and in the event that the specifications or information is inaccurate or actual operating conditions differ, any warranties or other provisions contained herein which are affected by such conditions shall be null and void, unless otherwise mutually agreed upon in writing.

14. **GENERAL PROVISIONS:** (a) Buyer shall not assign its rights or obligations under the Agreement without Seller's prior written consent. (b) There are no understandings, agreements or representations, express or implied, not specified in the Agreement. (c) No action, regardless of form, arising out of transactions under the Agreement, may be brought by either party more than two (2)

years after the cause of action has accrued. (d) Any modification of these terms and conditions must be set forth in a written instrument signed by a duly authorized representative of Seller. (e) The Agreement is formed and shall be construed, performed and enforced under the laws of the state of Georgia. However, Buyer and Seller agree that the proper venue for all actions arising under the Agreement shall be only in the State where the Goods involved in such actions were manufactured. (f) **GOODS AND SERVICES PROVIDED HEREUNDER ARE NOT SOLD OR INTENDED FOR USE IN ANY NUCLEAR OR NUCLEAR RELATED APPLICATIONS.** Buyer (i) accepts Goods and Services in accordance with the restriction set forth in the immediately preceding sentence, (ii) agrees to communicate such restriction in writing to any and all subsequent purchasers or users and (iii) agrees to defend, indemnify and hold harmless Seller from any and all claims, losses, liabilities, suits, judgments and damages, including incidental and consequential damages, arising from use of Goods and Services in any nuclear or nuclear related applications, whether the cause of action be based in tort, contract or otherwise, including allegations that the Seller's liability is based on negligence or strict liability. (g) The 1980 United Nations Convention on Contracts for the International Sale of Goods does not apply to this Agreement. (h) If any provision of the Agreement is invalid under any statute or rule of law, such provision, to that extent only, shall be deemed to be omitted without affecting the validity of the remainder of the Agreement.

4 Receipt of Shipment

When you receive your equipment inspect the outside of the packing case for damage which may have incurred during shipping. Damage incurred during shipment is the responsibility of the carrier and is not part of the factory warranty. If the packing case is damaged, notify the local carrier immediately.

If the package is in good condition remove the en-

velope containing the packing list and carefully remove the equipment and all components included in the shipment from the packing case. Inspect for damaged or missing parts, referring to the packing list, and prior to discarding the packing material.

If Items are missing from your shipment, contact your sales representative. Your sales order number will be required.

5 Return of Equipment

If the equipment must be returned to the factory for repair or replacement, a Returned Materials Authorization (RMA) must be included with the components.

RMA forms may be obtained from your sales representative or from the Product Service Department. In addition to the RMA, a Material Safety Data Sheet and a Decontamination Statement must be included with Items being returned to the factory. A Decontamination Statement is included in the back of this manual.

If the equipment is removed from service it must be thoroughly drained and neutralized before it is packed for shipment. Care must be taken to ensure that product removed from the equipment is disposed of in accordance with all applicable local, state and federal regulations.

The flanges should be sealed to keep residual fluid from leaking out of the meter during transport. The type of flange seal required will vary with the form of transportation used. Contact the carrier for specific instructions.

The equipment should be securely mounted on a wooden skid for shipment. The original container or a solid wooden box should be used to protect the exterior of the components.

When packing the components for return to the factory, place the RMA and a copy of the packing list that was delivered with the equipment inside an envelope. Place the envelope inside the shipping container with the Item being returned and reference the RMA number on the outside of the shipping container.

Equipment returned to the factory without the proper documentation will be returned to sender at their expense.

Ship the container to:
Brodie Meter Co., LLC
Product Service Department
19267 Highway 301 North
Statesboro, GA 30461, USA

Phone: +1 (912) 489-0200
Fax: +1 (912) 489-0294
service@brodieintl.com

6 Storage

Brodie International instruments are precision devices and should be handled and stored with care. They should not be subjected to rough or improper handling or stored in an environment where moisture, extreme temperatures, or foreign material can damage the meter.

The inlet and outlet flange covers should remain on the instrument until the unit is ready for installation.

If extended storage is required it is recommended that the instrument be placed in an environmentally controlled warehouse.

If this is not possible the instrument should be stored in a waterproof lined wooden box. Desiccant packs should be taped to the inside of the instrument end connections before they are sealed to reduce the effect of humidity on the equipment and accessories. Caution must be used to ensure desiccant packs are removed prior to installation.

Depending on the storage time it may also be preferable to use a compatible corrosion inhibitor.

If the meter is removed from service for an extended period of time it should be flushed with a light oil before being placed into storage.

7 Description

General

The BCBS Strainer is equipped with 1/2" NPT connections to allow mounting of differential pressure gauges or switches.

Strainers are installed in pipelines ahead of meters, pumps, valves, and other equipment to protect such equipment against intrusion of pipe scale, welding splatter and other foreign material. The use of the proper size strainer together with a basket of suitable mesh will aid in reducing maintenance on equipment in contact with flowing products.

Air Eliminators decrease the velocity of the flowing stream and bring the liquid to a state of relative calm

which allows air bubbles or vapor to rise. As air and vapors collect in the top of the vessel, liquid volume is displaced. Once displaced to a predetermined level, a float operated valve opens, and accumulated air and vapors are discharged. Liquid levels rise, causing the float operated valve to close. Discharge rates are determined by system backpressure on the outlet side of the air eliminator.

If sufficient pressure differential is not available to control the required discharge rate, a backpressure valve should be installed.

Specifications-Flow Ranges & Pressure

Model	Maximum Flow Rate		Maximum Operating Pressure		Recommened Maximum Pressure Drop	
	GPM	LPM	PSI	kPa	PSI	kPa
3" BCBSBE	900	3407	265	1827	15	103
4" BCBSBF	900	3407	265	1827	15	103
6" BCBSBG	1748	6617	265	1827	15	103

Note: Maximum flow based on mineral spirits (2.035 cst, 0.80 Specific Gravity)

8 Maintenance

General

To be efficient, strainer baskets must be kept clean. A build-up of sediment increases pressure drop and decreases flow. If a basket is allowed to become completely clogged, damage will result. Pressure gauges on each side of the strainer - or a differential pressure gauge - give an indication of basket condition at a glance.

A regular procedure should be set up for cleaning strainer baskets - the frequency depending on amount and character of foreign material in the stream. It is advisable to keep a spare basket (inner screen) on hand.

Recommended Mesh:

Gasoline and similar liquids

- 80 mesh for 2" strainers and smaller;

-60 mesh for larger strainers.

Diesel fuel, No. 2 Oil, etc. - 40 Mesh.

No. 5 or 6 Heating Oils, etc. - 20 Mesh.

9 Strainer Bill of Material

Strainer Body Size	Basket Type	Mesh Size					
		10	20	40	60	80	100
3 & 4"	Full Assembly	175410-010	175420	175425	175435	175445	175455
	Inner Screen Only	175405-010	175405-020	175430	175440	175450	175460
6"	Full Assembly	178720-010	178720-020	178730	178735	178740	178745

Air Eliminator-Strainer Component Part Numbers

Sequence Number	Description	Part Number
1	Strainer Body 3"	179304P
	Strainer Body 4"	179404P
	Strainer Body 6"	179604P
2	Strainer Cover 3" & 4" with 3/4" NPT vent	179305P () *
	Strainer Cover 3" & 4" with 2" NPT vent	179305-151P () *
	Strainer Cover 3" & 4" for SC Air Eliminator	179305-152P () *
	Strainer Cover 6" with 3/4" NPT vent	179605P () *
	Strainer Cover 6" with 2" NPT vent	179605-151P () *
	Strainer Cover 6" for SC Air Eliminator	179605-152P () *
3	Cover Plug 3/4" NPT	154711P
	Cover Plug 3/4" NPT (Low Temperature)	1501289P
	Cover Plug 2" NPT	154782-074M
	Cover Plug 2" NPT (Low Temperature)	1501291P
4	Stud and Nut Set 3" and 4", Cover	1501229M
	Stud and Nut Set, 3" and 4" Cover (Low Temperature)	1501299M
	Stud and Nut Set 6", Cover	159352M
	Stud and Nut Set, 6" Cover (Low Temperature)	1501298M
5	Washer for 3" and 4"	1501086
	Washer for 6"	1501115
6***	Gasket for 3" and 4"	179303
	Gasket for 6"	179603
7	Pressure Tap Plug 1/2" NPT	154704P
	Pressure Tap Plug 1/2" NPT (Low Temperature)	1500984P
8	Drive Screw	1501020
9	Strainer Name Plate	178602
10	Drain Plug 1.0" NPT	1501290P
	Drain Plug 1.0" NPT (Low Temperature)	154718-074P
11***	Full Basket Assembly	See above table
12	Basket Stud	151301
13	Basket Wingnut	151691
14	SC Air Eliminator Head	180121-XXXP**
15	Air Eliminator Bolts	150789M
	Air Eliminator Bolts (Low Temperature)	1500996M
16***	Air Eliminator O-Ring	157032-XXX**

Note:

*-LT Denotes Low Temperature Opinion

** -xxx See O-Ring / Elastomer Chart for Suffixes

*** Recommended Spare Parts

Strainer / Air Eliminator Spare Parts List

Sequence Number	Description	Part Number
6	Gasket for 3" and 4"	179303
	Gasket for 6"	179603
11	Full Basket Assembly	See above table
13	SC Air Eliminator_Diaphragm	180108-XXX*
15	SC Air Eliminator_O-Ring	157062-XXX*
16	Air Eliminator O-Ring	157032-XXX*

Note:

* -xxx See O-Ring / Elastomer Chart for Suffixes

O-Ring / Elastomer Suffix Chart

Name	O-Ring Suffix	Diaphragm Suffix
FFKM	-075	-075
ECO	-609	-609

Cast Body Strainer

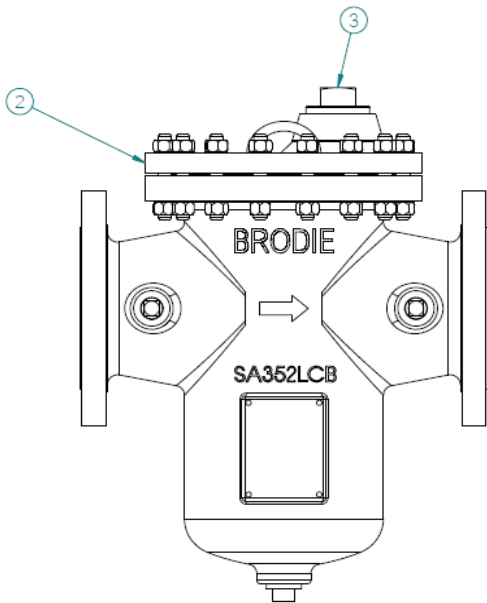
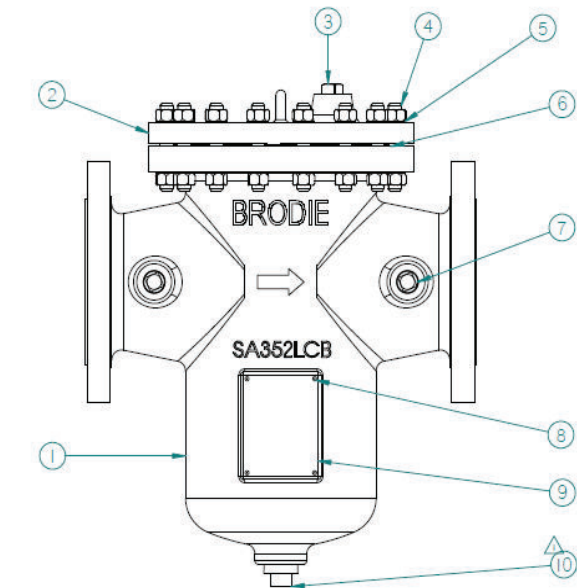

OPTION WITH
2" NPT COUPLING IN
COVER

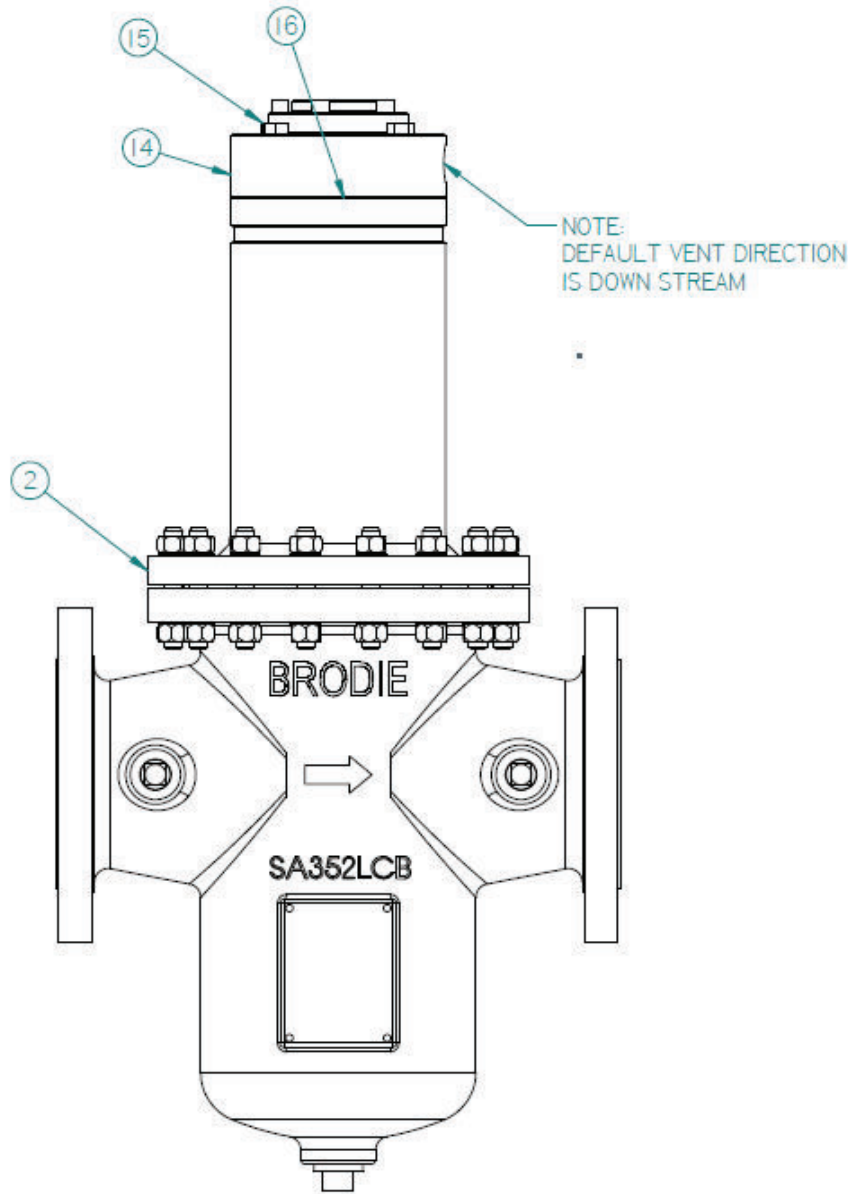

OPTION WITH
SC TYPE AE

Strainer Basket Configurations

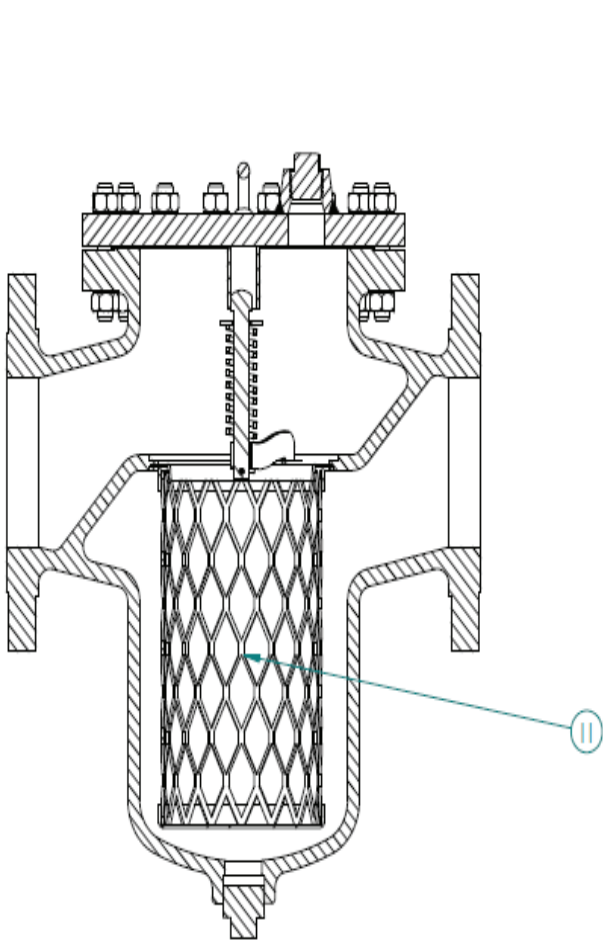

SECTION A-A

**3" & 4"
Strainer**

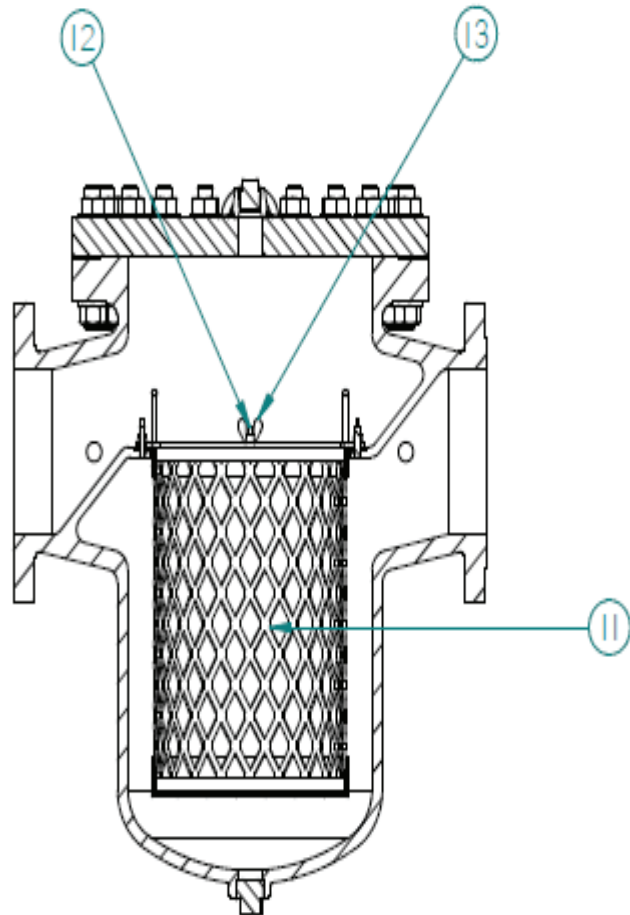

SECTION A-A

**6"
Strainer**

10 Troubleshooting

General

Periodic examination of all seals and O-rings for nicks, cuts, and wear is recommended, disassembly procedures are covered in Chapter #8 , Maintenance. If the strainer is found to be in need of repair, it is important that service be performed by trained and qualified service personnel and it is recommended that the user contact the Brodie Meter Co., LLC Repair Department.

The most frequent problem encountered with any strainer is the excess accumulation of sediment, rogue scale, and other foreign material in the basket. It is therefore good practice to periodically remove the basket from the strainer and inspect it for accumulation of these materials, as well as complete a flush of the strainer.

11 Air Eliminator Bill of Material

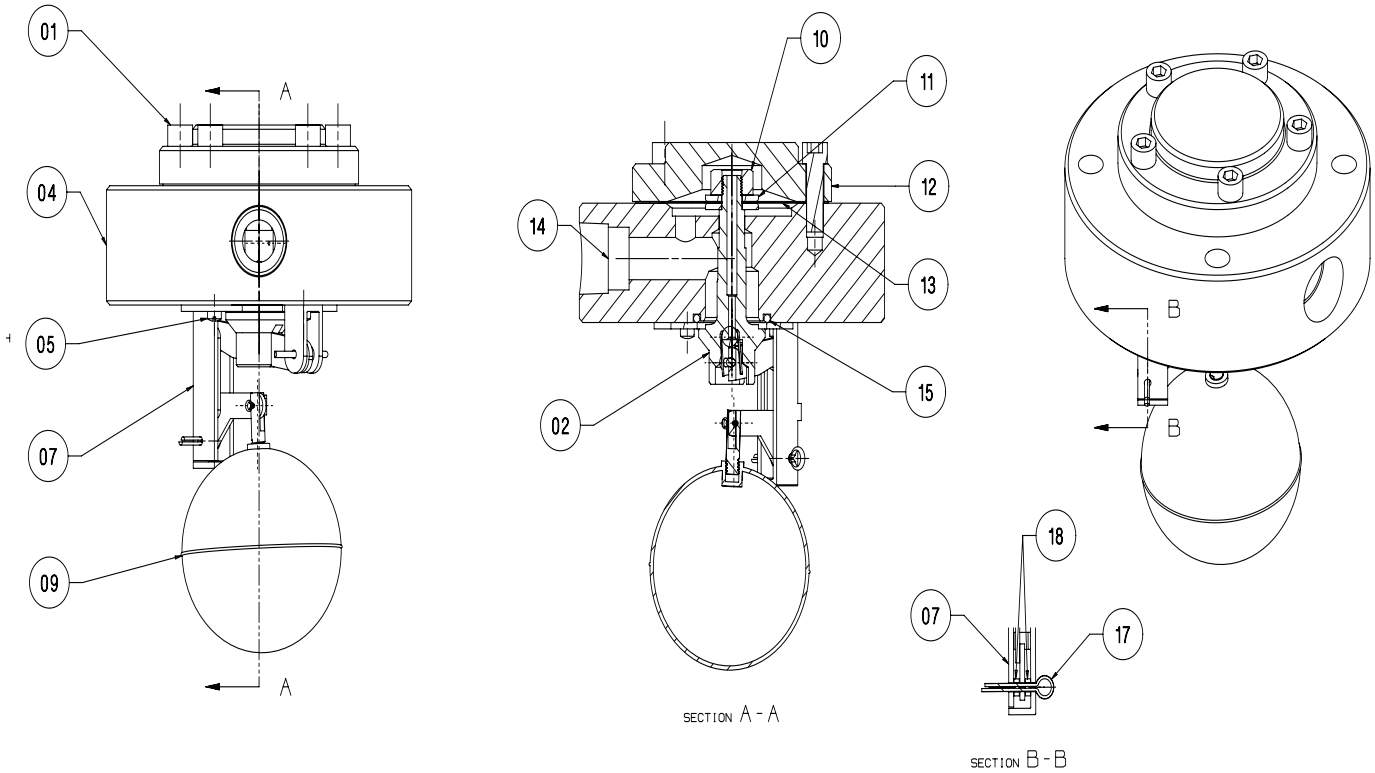

Item #	Description	Part Number	Qty
	AE Head Assembly	180121-XXXP*	
1	Screw - Allen Head	150997-419	5
2	Poppet	180494	1
4	Housing / Body	180102-001P	1
5	Screw - Slotted	150524-019	4
7	Bracket	180497	1
9	Float Link Assy	180105	1
10	Jam Nut	1501287	1
11	Diaphragm Washer	180495	2
12	Cover	180107-001P	1
13**	Diaphragm	180108-XXX*	1
14	Protector 3/4"	154754	1
15**	O-ring	157062-XXX*	1
17	Cotter Pin	1501288	2
18	Lever - Float Spacer	180438	4

*Note -XXX: See O-Ring / Elastomer Chart for Suffixes

** Recommended Spare Parts



B R O D I E
INTERNATIONAL



B R O D I E
INTERNATIONAL

Brodie International

P.O. Box 450 (30459-0450)
19267 Highway 301 North
Statesboro, GA 30461,
USA

Email: sales@brodieintl.com
Phone: +1 (912)489-0200
Fax: +1 (912) 489-0294