

## Technical Data

### Vane Meter

#### Model 792/793

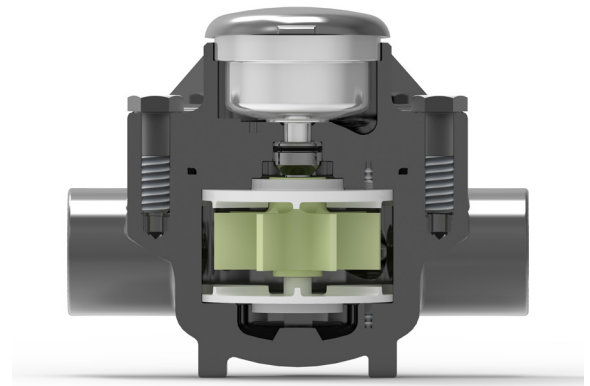

#### General

The 790 Series Vane meter for waterflood service and oils service, are compact, and reliable having only one moving part.

The corrosion resistant materials of the case and internal construction were selected specifically for secondary recovery water service, or oil service.

The register is a hermetically sealed unit with magnetic drive and is protectively sealed against moisture and dirt. No stuffing box, no wetted gear train, and dependable accuracy help make this meter the most reliable unit in its field.

Rotor assembly has teflon coated magnets for corrosion resistance and bearings are of a select carbon grade to extend rotor life.

The separate rotor shaft of chromed stainless steel is rigidly contained within the body to greatly improve meter life.

#### Principle of Operation

Fluid is directed to the vane off center, which causes the six bladed vane to rotate. A magnet fixed to the vane, drives the sealed register by a magnetic coupling.

#### Materials of Construction

**Upper Case:** Ni-Resist/Ductile Iron

**Lower Case:** Ni-Resist/Ductile Iron

**Rotor:** Glass Filled Polypropylene

**O-Rings:** Buna N

**Rotor Shaft & Other Wetted parts:** 316 St Stl

#### Ordering Information

In order to accurately process an order, such information as product to be controlled, product viscosity, product temperature range, ambient temperature range, rate of flow, operating pressure, and optional features needed must be specified by the customer.

#### Flow Capacities

7 to 75 BPH (1.1 - 11.9 M3/Hr.) - 793

3 to 30 BPH (.45 - 4.5 M3/Hr.) - 792

#### Ratings

Flanges: 1" Female NPT - (Inlet and Outlet)

Pressure Drop:

20 psi (138 kPa) at Max. Flow - 793

5 psi (34.5 kPa) at Max. Flow - 792

Maximum Working Pressure: 5,000 psi (34,500 kPa)

Maximum Temperature: 180°F (82°C)

#### Design Features

- Permanent volume record
- Full range accuracy
- Register isolated from line pressure
- Selected grade carbon bushings
- 75 BPH maximum
- No stuffing box
- 5000 psi working pressure
- Hermetically sealed register
- Non-wetted gear train

#### Performance

Accuracy: +/- 2.5% over 10 to 1 range

Repeatability: +/- 0.1%

#### Registration

Units of Measure: 6 Digit Totalizer, Straight Reading

Register: BBL or Cubic Meters

Smallest Division: 1/100 BBL or 1/1000 Cubic Meter

#### Viscosity

Maximum: 220 S.S.U.

#### Shipping Weight And Volume (Approximate)

Meter Size	Shipping Weight and Volume
1"	24 lbs @ 0.417 Cu. Feet
	10.89 kg @ 0.012 Cu. Meters

## Principle of Operation

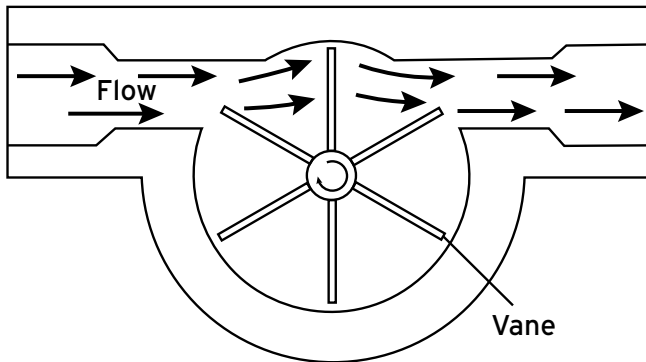

## Dimensions

(For Certified Dimensional Prints Consult Factory)

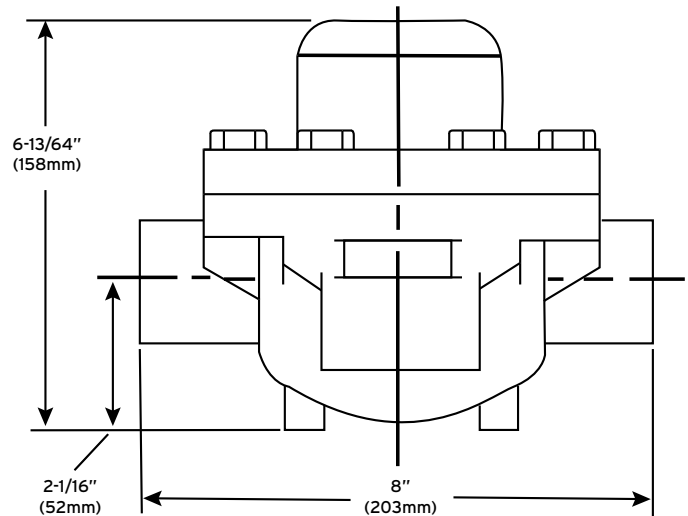
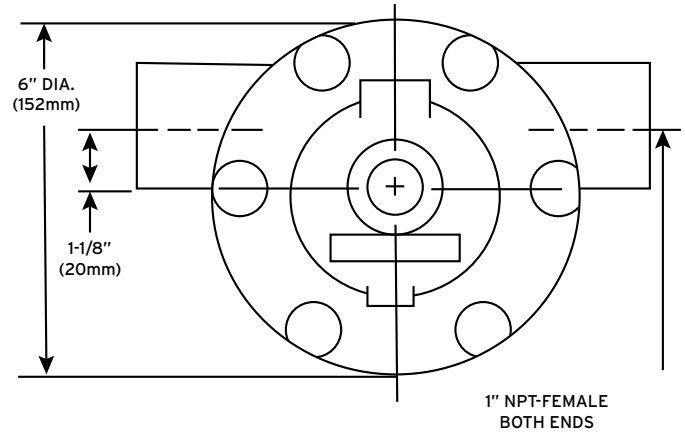

### Warning:

Do not operate this instrument in excess of the specifications listed. Failure to heed this warning could result in serious injury and/or damage to the equipment.

### Brodie International

P.O. Box 450 (30459-0450)  
 19267 Highway 301 North  
 Statesboro, GA 30461  
 USA

Phone: +1 (912) 489-0200  
 Fax: +1 (912) 489-0294